

Attachment 2

~~APPENDIX R~~

Appendix R
Closure Documentation Report

Report

Closure Documentation Report

Scope ID: 97M015 BL 36

**Modern Plating Corporation
Freeport, Illinois**

August 2001

August 3, 2001

Ms. Joyce L. Munie, P.E.
Manager, Permit Section Bureau of Land
Illinois Environmental Protection Agency
1021 N. Grand Ave. East
P.O. Box 19276
Springfield, IL 62794 - 9276

Dear Ms. Munie:

Re: Closure Documentation Report for Modern Plating Corporation

The purpose of this letter is to provide the closure documentation and the certification required by the April 11, 2000 RCRA Part B Permit Condition No. Section I, Condition H. 1. through 5. for the work conducted at Modern Plating Corporation. Attached is the original Closure Documentation Report and three copies for your review. The Closure Documentation Report is accompanied by the record drawings numbered 1 through 7 provided under separate cover. We have completed the construction, quality control and quality assurance testing of the cap, final cover, gas venting system for the Corrective Action Management Unit (CAMU). Also included in this report is documentation for the closure of wetland soils, the Shawnee Building soils, the cyanide vault, Lagoons No. 0, 1A, 1, 2 and 3, and the outfall pipeline.

The CAMU construction was started in early June 2000 and completed in April 2001. As you may be aware, representatives from the Illinois Environmental Protection Agency (IEPA) including Ms. Kathy Geyer visited the site for several days during the cap construction. IEPA's Ms. Geyer and Mr. Rob Watson, P.E. were kept up to date on the ongoing construction activities during all phases of the CAMU closure.

RCRA Part B permit Section I Condition E.1. requires that an exception report identify any changes to the design made during construction. The changes are discussed in Section 3 of the attached report.

Attachment 1 contains the Closure Certification form which must accompany this CAMU certification as per the RCRA Part B Permit Section I, Condition H. 5. which is signed and stamped by the certifying engineer, Mr. Marten J. Cieslik, P.E. and signed by the Modern operator, Mr. Craig Skolrood. The following is the wording of the Illinois Administrative

Ms Joyce L. Munie, P.E.
Illinois Environmental Protection Agency
August 3, 2001
Page 2

Code 35 IAC 702.126(d) which certifies that Phases 1 and 2 of the CAMU was closed in accordance with the June 11, 2000 IEPA RCRA Part B approval letter and the plans and specifications for the construction.

"I certify under penalty of law that this document and all attachments were prepared under my direction or supervision in accordance with a system designed to assure that qualified personnel properly gather and evaluate the information submitted. Based on my inquiry of the person or persons that manage the system, or those persons directly responsible for gathering the information, the information submitted is, to the best of my knowledge and belief, true, accurate, and complete. I am aware that there are significant penalties for submitting false information, including the possibility of fine and imprisonment for known violations,"

We respectfully request your expeditious review and approval of the attached closure documentation information. If you have any questions or require additional information, feel free to contact the undersigned.

Sincerely,

Foth & Van Dyke



Marten J. Cieslik, P.E.
Certifying Engineer



Brian J. Stanul, P.E.
Resident Engineer



Ronald E. Meister, P.G.
Project Manager

Attachment

cc: Mr. Craig Skolrood, MPC
Mr. Steve Laszewski, Foth & Van Dyke

Attachment 1

Closure Certification Form and IEPA Form LPC-PA18



RCRA INTERIM STATUS CLOSURE AND POST-CLOSURE CARE PLANS GENERAL FORM LPC-PA18

THIS FORM MUST ACCOMPANY ANY RCRA INTERIM-STATUS CLOSURE AND/OR POST-CLOSURE CARE PLANS OR MODIFICATION REQUEST SUBMITTED TO THE DIVISION OF LAND POLLUTION CONTROL. THE ORIGINAL AND TWO COPIES OF ALL DOCUMENTS SUBMITTED MUST BE PROVIDED.

FACILITY IDENTIFICATION (Information about the facility where the units are located which are addressed in this closure plan)

Name: MODERN PLATING CORPORATION County: STEPHENSON
Street Address: 701 SOUTH HANCOCK AVE Site # (IEPA): 1 7 7 0 2 0 0 0 1 0
PO BOX 838
City: FREEPORT, IL 61032 Site No. (USEPA): I L D 0 0 5 1 7 2 3 2 5

OWNER INFORMATION

Name: MODERN PLATING CORPORATION
Mailing Address: 701 SOUTH HANCOCK AVENUE PO BOX 838 FREEPORT, IL 61032
Contact Name: MR. CRAIG SKOLROOD
Contact Title: PRESIDENT
Phone #: (815) 235-3111

OPERATOR INFORMATION

MODERN PLATING CORPORATION
701 SOUTH HANCOCK AVENUE
PO BOX 838
FREEPORT, IL 61032
MR. CRAIG SKOLROOD
PRESIDENT
(815) 235-3111

TYPE OF SUBMISSION (check applicable item and provide requested information, as applicable)

Original (New) Closure Plan Log No. of Most Recent Agency Approval/Disapproval Letter
Original (New) Post-Closure Plan
Response to Disapproval letter Date of Most Recent Agency Approval/Disapproval Letter
X Modification Request AOC (DOCKET NO. V-W-88R-101)
X Additional Information for / / Submittal (Log No. if known)

DESCRIPTION OF SUBMITTAL: (briefly describe what is being submitted)

CLOSURE CONSTRUCTION DOCUMENTATION REPORT FOR PHASE I AND PHASE II OF THE CAMU LANDFILL AND THE REMEDIATION UNITS INCLUDING LAGOONS NO. 0, 1, 1A, 2 AND 3, THE CYANIDE VAULT, THE SHAWANEE BUILDING, THE OUTFALL PIPELINE AND THE WETLANDS.

LIST OF DOCUMENTS SUBMITTED (identify all documents in this submittal, including the cover letter)

COVER LETTER AND CLOSURE CONSTRUCTION DOCUMENTATION REPORT WHICH INCLUDES TABLES, FIGURES, APPENDICES AND DRAWINGS BOUND UNDER A SEPARATE COVER.

UNITS UNDERGOING CLOSURE (please identify what type of units are addressed in the plan, their capacities and whether they are on the RCRA Part A for the facility)

Table with 5 columns: Unit, Unit Code, Number of Units Closing, Capacity, On Part A (Y/N). Rows include Storage: Container (barrel, drum, etc.) S01, Tank S02, Waste Pile S03, Surface Impoundment S04. Values: 3 (LOG #C-259) ~ 11.730 CY, LAGOONS 1, 2 AND 3.

UNITS UNDERGOING CLOSURE (continued)

<u>Unit</u>	<u>Unit Code</u>	<u>Number of Units Closing</u>	<u>Capacity</u>	<u>On Part A (Y/N)</u>
<u>Treatment:</u>		(1) CYANIDE		
Tank	T01	TREATMENT VAULT	200 CY	Y
Surface Impoundment	T02	_____	_____	_____
Incinerator	T03	_____	_____	_____
Other (explain)	T04	_____	_____	_____
<u>SHAWANEE BUILDING (LOG NO. C-472)</u>		(1) CONTAMINATED SOILS	30 CY	Y
<u>Disposal:</u>		(2) CLOSED LAGOONS		
Landfill	D80	_____	_____	_____
Land Application	D81	0 AND 1A	2,280 CY	Y
Surface Impoundment	D83	_____	_____	_____

CERTIFICATION AND SIGNATURE (Must be completed for all submittals. Certification and signature requirements are set forth in 35 IAC 702.126. Any submittal involving engineering plans, specifications and calculations as defined in the Illinois Professional Engineering Act and 68 IAC 1380 must be signed and certified by an Illinois registered professional.)

All closure plans, post-closure plans and modifications must be signed by the person designated below or by a duly authorized representative of that person:

- Corporation - By a principal executive officer of at least the level of vice-president.
- Partnership or Sole Proprietorship - By a general partner or the proprietor, respectively.
- Government - By either a principal executive officer or a ranking elected official.

A person is a duly authorized representative only if:

1. the authorization is made in writing by a person described above; and
2. is submitted with this application (a copy of a previously submitted authorization can be used).

I certify under penalty of law that this document and all attachments were prepared under my direction or supervision in accordance with a system designed to assure that qualified personnel properly gather and evaluate the information submitted. Based on my inquiry of the person or persons who manage the system, or those persons directly responsible for gathering the information, the information submitted is, to the best of my knowledge and belief, true, accurate, and complete. I am aware that there are significant penalties for submitting false information, including the possibility of fine and imprisonment for knowing violations.

Owner Signature: *P. Smith F. Miller* _____ 4/16/01
 Title: _____ (Date)

Operator Signature: *Allen Schubert* _____ 4/16/01
 Title: PRESIDENT _____ (Date)

Engineer Signature: *Marten J. Cieslik* _____ 6/26/01
 (if necessary)
 Engineer Name: MARTEN J. CIESLIK
 Engineer Address: 406 SCIENCE DRIVE, STE 400
MADISON, WI 53711-1068
 Engineer Phone No.: (608) 238-4761

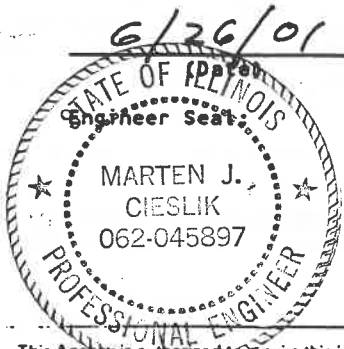

This Agency is authorized to require this information under Illinois Revised Statutes, 1979, Chapter 111 1/2, Section 1039. Disclosure of this information is required under that Section. Failure to do so may prevent this form from being processed and could result in your application being denied. This form has been approved by the Forms Management Center.

CEVIT 0000
R001848
0005 P 5 090

April, 2000 NYG WA. 3 11 00

1770200010
Modern Plating Corporation
RCRA Log No. B-167

This statement is to be completed by both the responsible officer and by the registered professional engineer upon completion of closure. Submit one copy of the certification with original signatures and three additional copies.

Closure Certification Statement

The Corrective Action Management Unit (CAMU) at the Modern Plating facility in Freeport, Illinois as described in RCRA permit application Log No. B-176 has been closed in accordance with the specifications and requirements in the Illinois EPA approved permit application.

I certify under penalty of law that this document and all attachments were prepared under my direction or supervision in accordance with a system designed to assure that qualified personnel properly gather and evaluate the information submitted. Based on my inquiry of the person or persons who manage the system, or those persons directly responsible for gathering the information, the information submitted is, to the best of my knowledge and belief, true, accurate, and complete. I am aware that there are significant penalties for submitting false information, including the possibility of fine and imprisonment for knowing violations.

ILD005172325
USEPA ID Number

Modern Plating Corporation - CAMU
Facility Name

Lucille Miller
Signature of Owner

Ms. Lucille Miller, Owner
Name and Title

Craig Skolrood
Signature of Operator

Mr. Craig Skolrood, President
Name and Title

Marten J. Cieslik
Signature of Registered P.E.

Mr. Marten J. Cieslik, P.E.
Name of Registered P.E. and Illinois
Registration Number # 062-045897

6-26-01
Date

P.E. Seal and
Expiration Date of License

11/30/01



Closure Documentation Report

Scope ID: 97M015 BL 36

Prepared for
Modern Plating Corporation
Freeport, Illinois

Prepared by
Foth & Van Dyke and Associates Inc.

August 2001

REUSE OF DOCUMENTS

This document has been developed for a specific application and not for general use; therefore, it may not be used without the written approval of Foth & Van Dyke and Associates. Unapproved use is at the sole responsibility of the unauthorized user.

Copyright©, Foth & Van Dyke 2001

2737 S. Ridge Road, P.O. Box 19012, Green Bay, Wisconsin 54304, 920/497-2500, FAX: 920/497-8516

Closure Documentation Report

Contents

	Page
1 Certification	1
1.1 Purpose	1
1.2 Closure Certification	1
1.3 Quality Assurance Personnel Summary	1
2 Introduction	3
2.1 Project Background	3
2.2 Report Purpose and Scope	5
2.3 Liability Insurance	6
2.4 Financial Assurance for Long-term Care	6
3 Deviations from the Permit Conditions or Plans and Specifications	7
4 Chronological Summary of Closure Activities	8
5 Final Waste Placement and Grading	10
5.1 Final Waste Grades	10
5.2 Total Volume of Wastes in the CAMU	10
5.3 Waste Conditions at the Start of the Final Cover Construction	10
6 Final Cover Construction	11
6.1 Gas Venting Layer Construction	11
6.2 Gas Venting System Construction	11
6.3 Geosynthetic Liner (GCL) Construction	12
6.3.1 General	12
6.3.2 Material Conformance Testing and Inspection	12
6.3.3 GCL Deployment	15
6.4 Geomembrane Liner Construction	15
6.4.1 General	15
6.4.2 Material Conformance Testing and Inspection	15
6.4.3 Preproduction Weld Testing	15
6.4.4 Geomembrane Panel Deployment and Seaming	18
6.4.5 Non-Destructive Seam Testing	18
6.4.6 Destructive Seam Testing	19
6.4.7 Repair Documentation	22
6.5 Geocomposite Construction	22
6.5.1 General	22
6.5.2 Panel Layout and Seaming	22
6.5.3 Geocomposite Conformance Testing	22

6.6	Rooting Zone Placement	23
6.6.1	Soil Material Properties	23
6.6.2	Rooting Zone Drainage	23
6.6.3	Rooting Zone Construction Observation	24
6.7	Topsoil Placement and Establishing Vegetation	24
6.8	CAMU Site Security	24
7	Final Grades Survey	25
8	Survey Plat for the CAMU	26
8.1	General	26
8.2	Survey Plat and Plat Notes	26
8.3	Documentation of the Filing of the Survey Plat	27
9	Closure of Wetland and Shawnee Building Soils	28
9.1	Wetland and the Shawnee Building Soils	28
9.1.1	Sampling and Analysis Procedures	28
9.1.2	Wetland No. 1	33
9.1.3	Wetland No. 1A	33
9.1.4	Wetland No. 2	33
9.1.5	Wetland No. 3	34
9.1.6	Shawnee Building Soils	34
10	Backfilling and Restoration of the Lagoons, Wetlands, Shawnee Building and Other Units	35
10.1	Wetland Soil Areas No. 1, 1A, 2 and 3	35
10.2	Shawnee Building	35
10.3	Cyanide Vault	35
10.4	Lagoon No. 0	40
10.5	Lagoon No. 1A	40
10.6	Lagoon No. 1	40
10.7	Outfall Pipeline (Additional Work)	41
11	Inspection of the CAMU	42
12	Conclusions and Desired Response	43

Tables

Table 1-1	Foth & Van Dyke Quality Assurance Personnel	2
Table 4-1	Chronological Summary of Closure Activities	9
Table 6-1	Summary of Laboratory Results - Gas Venting/Grading Layer	11
Table 6-2	GCL Laboratory Conformance Testing Summary	13
Table 6-3	Summary of Laboratory Test Results-Geomembrane Conformance Testing	16

Table 6-4	Destructive Seam Laboratory Test Results (ASTM D4437)-Final Cover	20
Table 6-5	Summary of Laboratory Results-Geocomposite Conformance Testing	23
Table 9-1	Summary of Soil Test Results Wetland and Shawnee Building Soils	29
Table 9-2	Summary of PID Readings Waste Excavation and Handling	31
Table 10-1	Summary of Standard Proctors for Cover Soils for the Remediated Units . . .	36
Table 10-2	Summary of Density/Moisture Tests on Cover Soils of the Remediated Units	37

Appendices

Appendix A	Construction Observation Photographs
Appendix B	Gas Venting System Material Information
	B1 - Grading/Gas Venting Layer Laboratory Report
	B2 - Gas Venting System Manufacturer's Data
Appendix C	GCL Material Information
	C1 - Subgrade Acceptance Forms
	C2 - GCL Manufacturer's QC Data and Product Information
	C3 - GCL Laboratory Results
	C4 - GCL Panel Placement Summary Forms
Appendix D	Geomembrane Material Information
	D1 - Geomembrane Roll Inventory Form
	D2 - Manufacturer's Roll Test Data Reports
	D3 - Manufacturer's Resin Quality Assurance Test Results
Appendix E	Geomembrane Conformance Laboratory Test Results from Precision Geosynthetic Laboratories, Inc.
Appendix F	Geomembrane Installation Forms
	F1 - Daily Geomembrane Installation Field Reports
	F2 - Preproduction Weld Logs
	F3 - Panel Placement Summary Forms
	F4 - Panel Seaming Summary Forms
	F5 - Non-Destructive Seam Test Summary Forms
	F6 - Destructive Seam Sample Summary Forms
	F7 - Repair Summary Forms
Appendix G	Geomembrane Destructive Seam Laboratory Test Results
Appendix H	Geocomposite Material Information
	H1 - Geocomposite Manufacturer's Information
	H2 - Geocomposite Conformance Laboratory Results
Appendix I	Rooting Zone Grain Size Analysis - Giles Engineering Assoc., Inc.
Appendix J	Survey Plat for the CAMU Landfill Documentation
Appendix K	Soil Isoconcentration Contour Maps - Shawnee Building and Wetlands
Appendix L	Procedures for Sampling Wetland and Other Soils and Sludges from the Revised Construction Quality Assurance Plan and SOPs for Solids/Semi-Solids Sampling and Chain-of-Custody Documentation
Appendix M	Wetland Soils and Shawnee Building Soils - Conformation Location Sketches, Cadmium Analysis and Chain-of-Custody Forms

Appendix N	Field and Laboratory Test Results - Compaction Soil Fill for Remediated Unit Covers
Appendix M	Security Fence Information and Inspection Reports

Drawings

Drawing No. 1	Title Sheet
Drawing No. 2	Top of Grading/Gas Venting Layer
Drawing No. 3	As Constructed GCL Panel Layout
Drawing No. 4	As Constructed Geomembrane Panel Layout
Drawing No. 5	CAMU Final Grades Showing the Gas Venting System
Drawing No. 6	Details
Drawing No. 7	Details

1 Certification

1.1 Purpose

The purpose of this Closure Documentation Report is to provide the certification required by 35 IAC 702.126(d), 35 IAC 724.652 and comply with Section I, Condition H. 1. through 5. of the April 11, 2000 RCRA Part B Permit for Modern Plating Corporation. This report contains all the information required by Attachment A of the referenced permit.

1.2 Closure Certification

As per permit condition Section I, Conditions E.5., the following is the closure certification which contains the wording required in 35 IAC 702.126(d). Attachment 1 to the cover letter contains the closure certification form and the LPC-PA18 form which must accompany the certification which is signed and stamped by the certifying engineer, Mr. Marten J. Cieslik, P.E., DEE and signed by the site operator, Mr. Craig Skolrood of the Modern Plating Corporation.

The following is the wording from 35 IAC 702.126(d) which certifies that the Corrective Action Management Unit (CAMU) Landfill was closed in accordance with the April 11, 2000 RCRA Part B application approvals and the Foth & Van Dyke plans and specifications for the construction.

“I certify under penalty of law that this document and all attachments were prepared under my direction or supervision in accordance with a system designed to assure that qualified personnel properly gather and evaluate the information submitted. Based on my inquiry of the person or persons that manage the system, or those persons directly responsible for gathering the information, the information submitted is, to the best of my knowledge and belief, true, accurate, and complete. I am aware that there are significant penalties for submitting false information, including the possibility of fine and imprisonment for known violations.”

1.3 Quality Assurance Personnel Summary

Table 1-1, Quality Assurance Personnel, identifies each professional engineer or qualified technician who performed quality assurance during the remedial construction, including on-site quality assurance and the role each individual played on the preparation of the Closure Documentation Report.

Table 1-1

**Foth & Van Dyke Quality Assurance Personnel
Modern Plating Remediation**

Construction Task	BJS1 P.E.	MJC1 *P.E.	REM L.P.G.	JRL L.S.	STS P.E.	JOW C.E.T.	JDP L.S.
Abandoning and final covering of the remediated units	X	-	-	-	-	-	-
Top of waste topographic survey	X	-	-	X	X	-	-
Grading layer and gas venting system construction	X	X	-	-	X	-	-
CAMU cap installation	X	X	X	X	X	-	-
Construction of rooting zone and topsoil layers	X	X	-	-	X	-	-
Final grades survey	-	-	-	X	X	-	-
Survey plat for the CAMU landfill	X	-	-	X	-	-	X
Preparation of the construction documentation report, including tables and appendices	X	X	X	-	-	-	-
Preparation of the construction documentation "as-built" drawings	X	X	X	-	X	X	-

C.E.T. = Certified Engineering Technician
 P.E. = Professional Engineer
 *P.E. = Certifying Professional Engineer
 L.P.G. = Licensed Professional Geologist
 L.S. = Licensed Land Surveyor
 BJS1 = Brian J. Stanul
 MJC1 = Marten J. Cieslik
 REM = Ronald E. Meister
 JRL = James R. Logan
 STS = Secret T. Strobl
 JOW = John O. Whitstone
 JDP = James D. Prehn

2 Introduction

2.1 Project Background

The RCRA Corrective Action and Closure process for the Modern Plating Corp. (Modern) facility dates back to the mid 1980s and has involved, at various points in time, regulatory oversight authority under both the U.S. EPA and the IEPA.

In November 1980, a RCRA Part A permit application was submitted. In July 1984, a RCRA Part B permit application was submitted. Compliance inspections and groundwater sampling of the Modern facility were conducted by the IEPA between September 1981 and June 1987.

In March 1984, Modern received a hazardous ranking system score of 22.4. In July 1985, Modern was placed on the Illinois Remedial Action Priorities list. The U.S. EPA issued a Complaint and Compliance Order dated June 18, 1985, which specified the U.S. EPA's determination of violations by Modern of the Resource Conservation and Recovery Act as amended. Modern entered into a Consent Agreement and Final Order with the U.S. EPA on November 23, 1985. On September 3, 1986, the U.S. EPA approved the Assessment Monitoring Program for Modern's RCRA lagoons.

The approved Assessment Monitoring Program was implemented in September 1986, and reported in 1987 (Foth & Van Dyke, 1987a). Twelve groundwater monitoring well locations (labeled MW-5C, MW-5D, MW-6A, MW-6B, MW-6C, MW-7A, MW-7B, MW-7C, MW-7D, MW-8A, MW-8B, and MW-8C), were installed and developed.

A second phase of assessment monitoring and well installation was performed during August and September 1987 (Foth & Van Dyke, 1987b). Twenty additional groundwater monitoring wells and well nests (labeled MW-11A, MW-11B, MW-11C, MW-11E, MW-12A, MW-12B, MW-12C, MW-12E, MW-13A, MW-13B, MW-13C, MW-13E, MW-14A, MW-14B, MW-14C, MW-14E, MW-15A, MW-15B, MW-15C, and MW-16C) were installed at six locations.

In November 1986, a revised partial closure/post-closure care plan was submitted to the IEPA. This plan was approved by the IEPA on January 23, 1987, with several conditions. An addendum to the plan was submitted to the IEPA on March 20, 1987, and the plan modification was approved by the IEPA on June 19, 1987.

Previously, the IEPA issued a Notice Pursuant to Section 4 (q) of the Environmental Protection Act on June 20, 1986. As a result of this notice, a situation/preliminary report was submitted to the IEPA on September 18, 1986. Comments on the report were addressed on October 30, 1986. In addition, in December 1986, a remedial investigation work plan was submitted to the IEPA. An amended remedial investigation work plan was submitted to the IEPA in 1987. The amended work plan was not reviewed because Modern requested negotiations for a Consent Order to combine Federal and State actions. Negotiations between Modern and the U.S. EPA resulted in a

Consent Order signed by the U.S. EPA on December 31, 1987, which became effective on January 15, 1988.

In February 1988, a RCRA Facility Investigation (RFI) work plan was submitted to the U.S. EPA and the IEPA. A revised RFI work plan was submitted to the U.S. EPA and the IEPA in June 1988. A second revised RFI work plan was submitted in September 1988. The U.S. EPA approved the RFI work plan on December 31, 1988. In February 1988, a Description of Current Conditions report was submitted to the U.S. EPA. A revised Description of Current Conditions was submitted in June 1988.

The RFI program constituted the third hydrogeologic investigation at the Modern facility. Hydrogeological, soil, surface water, and sludge characterization work was reported in the February 1990 RFI (Foth & Van Dyke 1990). In May 1991, a report titled *Final Corrective Measures Study (CMS) for the Modern Plating Facility - Part II, Volumes I and II*, presented Modern's preferred alternative for remediation of soil, groundwater and electroplating sludge at the facility.

Four subsequent CMS reports addressed the U.S. EPA's and the IEPA's comments on Modern's preferred alternative. Those reports were titled:

- ◆ *Final Corrective Measures Response to U.S. EPA Comments* (October 1991)
- ◆ *Final Corrective Measures Study, Response to U.S. EPA Comments, Response No. 2*, July 1992
- ◆ *Corrective Measures Study, Soil sampling Plan*, March 1993
- ◆ *Modern Plating Corporation - Response to July 21, 1993 Letter*

As a result of the reports, studies, review, and investigations, Modern submitted a Final Corrective Measures Study-Compendium Report on May 3, 1995. This report addressed IEPA and U.S. EPA comments and concerns regarding the RCRA Closure Plan for all RCRA and non-RCRA-regulated units, and provided final remedy selection. The Compendium Report recommended the phased excavation, treatment and off-site disposal of site wastes in addition to a phased implementation of a groundwater recovery system for remediating contaminated groundwater at the site.

In a September 4, 1996 letter, the U.S. EPA formally approved the CMS. In an October 17, 1996 IEPA letter to the U.S. EPA, the State of Illinois formally requested oversight of the Modern site for implementation of the corrective action. The U.S. EPA granted the IEPA's request and also terminated the Administrative Order on Consent.

On March 19, 1997, Modern met with the IEPA to discuss modifications to the RCRA Closure Plan. As a result of this meeting and the transfer of regulatory oversight from the U.S. EPA to

the IEPA, it was agreed that Modern would submit a revised RCRA Closure Plan that provides a comprehensive summary of the site history, a Tiered Approach to Corrective Action Objectives (TACO) analysis for soil and groundwater cleanup objectives, remediation cost estimates, and a post-closure care and monitoring plan.

On September 25, 1997, Foth & Van Dyke and Modern met with members of IEPA review staff to discuss the RCRA Closure Plan and contents of a RCRA Part B Permit Application (Part B Application). At the September 25, 1997 meeting an outline of the Part B Application and list of items felt to be inapplicable were presented to the IEPA staff for review. In a letter dated November 20, 1997, IEPA responded with comments regarding the outline and provided comments on the proposed landfill design.

Foth & Van Dyke, on behalf of Modern, submitted the final RCRA closure plan for the facility on July 22, 1999 titled *Final RCRA Closure Plan and Basis Design Report (Volume I and Volume II)*. The closure plan addressed remediation of both the RCRA-regulated units (Lagoon No.1, Lagoon No.2, Lagoon No. 3, and Shawnee Building soils), and non-RCRA-regulated units which included Lagoon No. O, Lagoon No. 1A, the cyanide treatment vault, and impacted wetland soils.

The Part B Permit Application submitted in December, 1999 addresses separate but related issues that are addressed in the RCRA Closure Plan Log No. C-472-M-10 (Foth & Van Dyke, 1997). The Closure Plan provides a review and presentation of data on the environmental conditions at the Modern facility. These data provide the basis for establishment of cleanup goals and remedy selection. The closure plan also presents a conceptual approach to the design of the CAMU. The Part B permit relates to the RCRA Closure Plan by presenting detailed design plans for disposing and containing the wastes that are targeted for cleanup as described in the RCRA Closure Plan Log No. C-472-M-10.

2.2 Report Purpose and Scope

The purpose and scope of this report is to document the CAMU closure specified in the final RCRA closure plan for the Modern facility and to document that the materials and methods used in the closure of the CAMU landfill meet the RCRA Part B permit conditions and to conform to the requirements of the plans and specifications. In addition, this report documents the closure of the other hazardous waste and solid waste management units on the site, including Lagoons No. 0 and 1A, the cyanide vault, the abandon effluent pipeline, the wetlands and the Shawnee Building.

The construction certification requirements for the CAMU are located in the April 11, 2000 RCRA Part B Permit for the CAMU in Section I, E. Items 1 through 5 and Attachment A. Attachment A of the April 11, 2000 permit contains a list of the items which must be contained in the construction documentation. Attachment A of the April 11, 2000 permit is provided in Appendix A for reference. The report which follows provides the data necessary to certify that closure of the CAMU was performed according to the RCRA Part B permit and the plans and

specifications and is submitted in conjunction with the report titled *CAMU Landfill Construction Documentation, Modern Plating Corporation*, dated July 2001, which documents the construction and certification of the CAMU landfill and the remediation of the eight management units specified in the final RCRA Part B Permit for the Modern facility.

2.3 Liability Insurance

Modern Plating Corporation (Modern) understands that with the remediation and closure of the solid and hazardous waste units described in this report and the construction and closure of the CAMU that liability insurance is no longer required by the IEPA.

2.4 Financial Assurance for Long-term Care

Modern has contacted First Star concerning financial assurance for long-term care. The financial instrument currently being processed is a standby letter of credit. Modern expects to receive the required financial instrument by early August 2001. First Star will forward it to the IEPA when received.

3 Deviations from the Permit Conditions or Plans and Specifications

When deviations from the plans and specifications or permit conditions occurred during the project, Rob Watson, P.E., the IEPA project environmental engineer, was contacted by telephone and given an explanation of the proposed modifications and an explanation of the rationale for the implementation of the modifications. The following is a list of minor deviations to project plans and specifications which were implemented in the field as a reaction to field conditions.

- ◆ Wetland areas No. 1, 2, and 3 were backfilled to their original grades using an on-site organic soil stockpile. Refer to Section 10.
- ◆ Since the amount of drainage coming from the final cover rooting zone is small, the proposed riprap on the perimeter berm was replaced with breaker run stone. Refer to Section 6.6.2 and Drawing No. 6, Detail 6/1.
- ◆ The stainless steel risers and steel protective covers on monitoring wells MW-8A, 8B, and 8C were extended to maintain a minimum of a 2-ft elevation above the ground surface after the berm for Sedimentation Basin No.1 was constructed. MW-8A was extended 5 ft, while MW-8B and 8C were extended 2.5 ft. The monitoring wells were re-surveyed along with the other site monitoring wells. The re-survey of the wells was reported in the July 2001 groundwater monitoring report for the facility.
- ◆ The design for the perimeter berm drainage ditch was modified along the south side of the CAMU to improve the stormwater flow to the sedimentation basins. Refer to Drawing No. 5.

4 Chronological Summary of Closure Activities

The closure activities consisted of final waste placement in the CAMU, waste grading, final cover construction, final grades survey, survey plat for the CAMU, and the abandonment of the remediated units. The closure construction described in this report was completed by Terra Engineering and Construction, Inc. (Terra) of Madison, Wisconsin and documented by a Foth & Van Dyke resident project representative. Foth & Van Dyke also performed the surveying required by the RCRA permit. Table 4-1 provides a chronological summary of the closure activities. Photographs of the major construction activities related to the closure are included in Appendix A.

Table 4-1

**Chronological Summary of Closure Activities
Modern Plating Corporation Remediation**

Dates	Description
July 20, 2000	Closure of Cyanide Vault
July 21, 2000	Closure of Shawnee Building
October 31, to November 2, 2000	Closure of Outfall Pipeline
November 2, 2000 to January 3, 2001	Closure of Wetland No. 1A
November 27, to December 1, 2000	Closure of Lagoon No. 1A
November 28, to November 30, 2000	Closure of Lagoon No. 0
December 12, to December 15, 2000	Final waste grades survey
December 13, to December 19, 2000	Placement of grading/gas venting layer
December 18, to December 27, 2000	Closure of Wetland No. 3
December 18, 2000 to January 5, 2001	Closure of Lagoon No.1
December 26, 2000 to January 25, 2001	Installation of gas venting system
December 28, 2000 to January 3, 2001	Closure of Wetland No.1
December 28, 2000 to January 3, 2001	Closure of Wetland No. 2
January 13, to January 14, 2001	Geosynthetic Clay Liner (GCL) installation
January 13, to January 17, 2001	Geomembrane installation
January 16, to January 17, 2001	Geocomposite installation
January 18, to January 23, 2001	Placement of rooting zone
January 23, to January 25, 2001	Placement of topsoil
April to July 2001	Construction of security fence
February 28 and May 2, 2001	CAMU final cover survey
July 5, 2001	CAMU plat survey
February 28, 2001	Post-closure survey of site monitoring wells

Prepared By: BJS1
Checked By: REM

5 Final Waste Placement and Grading

5.1 Final Waste Grades

After the sludge and contaminated soils generated during the remediation activities were placed in the CAMU and graded using a low ground pressure (LGP) bulldozer, a Foth & Van Dyke registered land surveyor completed a topographic survey of the final waste grades on an approximately 50-ft grid. Drawing No. 5 shows the top of final waste grades.

5.2 Total Volume of Wastes in the CAMU

The total volume of wastes placed in the CAMU was calculated by comparing the top of waste topography survey with the record elevations survey for the top of liner of Phases 1 and 2 using Intergraph SiteWorks™ program on CADD. The total volume of soil and sludge excavated was 19,800 cy. The total volume of sludge and soil placed in the CAMU was approximately 14,500 cy (based on surveys performed on the CAMU liner and top of sludge grades). The difference in volumes is attributed to dewatering of the sludges and soils prior to placement in the CAMU and compaction and consolidation of sludges and soils once placed in the CAMU.

5.3 Waste Conditions at the Start of the Final Cover Construction

At the start of final cover construction, the waste had been graded by back-dragging the waste with a LPG bulldozer to assure a smooth surface and to achieve a minimum 5% slope across the top of the waste. Due to compaction, consolidation, dewatering, and stabilization of the sludges, and frost penetration due to the cold weather in December and January, the waste was able to support heavy equipment such as bulldozers, front end loaders, and dual axle dump trucks without rutting or pumping.

6 Final Cover Construction

The CAMU final cover installation consisted from bottom to top of a 6-in thick grading/gas venting layer, a gas venting system, a geocomposite clay layer (GCL), a geomembrane, a geocomposite, a 2.5-ft thick rooting zone soil layer, and a 6-in thick topsoil layer. Drawing No. 6 Detail No. 6/1 shows the details of the final cover.

6.1 Gas Venting Layer Construction

The sand gas venting/grading layer was placed directly on top of the waste in a single 6-in thick lift with an LPG bulldozer. The bulldozer then back-dragged the top of the sand layer to a smooth grade. The thickness of the sand layer was field verified by the Foth & Van Dyke resident project representative using a shovel to dig to the bottom of the layer on an approximately 50-ft grid. The minimum 6-in thickness was verified.

A sample of the sand was submitted to Giles Engineering (Giles) of Madison, Wisconsin for USCS Soil Classification (ASTM D2478) and Grain Size (ASTM D422) analyses. Table 6-1 summarizes that laboratory results. A copy of the laboratory report is included in Appendix B.

Table 6-1

**Summary of Laboratory Results - Gas Venting/Grading Layer
Modern Plating Corporation
CAMU Closure**

Sample No.	USCS Description (ASTM D2488)	% Sand/P200/Cu	USCS Soil Classification
MPC-GRADING-1	Poorly graded sand	98.0/20/4.00	SP
Specifications	Soil Class D-3	95/<5/NS	

NS = Not Specified

Prepared by: BJS1
Checked by: REM

6.2 Gas Venting System Construction

The gas venting system was designed to allow gases produced by the waste in the CAMU to passively vent into the atmosphere to prevent gas buildup from occurring beneath the geomembrane cap. The gas venting system consisted of 6-in diameter slotted polyethylene pipe installed in the grading/gas venting layer. At four locations along the gas vent pipe, a polyvinyl chloride (PVC) tee connected to a 6-in diameter Schedule 80 PVC riser, and a 180° PVC elbow were installed to allow the gas to vent into the atmosphere. Drawing No. 5 shows the location of the gas vent piping and risers. The construction of the gas vent is shown as Detail 7/2 of

Drawing No. 7. The pipe manufacturer's information for the gas venting system material is included in Appendix B2.

6.3 Geosynthetic Liner (GCL) Construction

6.3.1 General

The GCL for the final cover was installed by Midessa Industrial Vinyl Co. of Odessa, Texas (Midessa). The installation was observed and documented by Foth & Van Dyke field personnel. Prior to the placement of the GCL panels for the final cover, written acceptance of the subbase was obtained from the Midessa field supervisor. The subgrade acceptance form is included in Appendix C1. The GCL rolls installed were Bentomat DN manufactured by CETCO, Inc. of Arlington Heights, Illinois (CETCO). The GCL manufacturer's information is included in Appendix C2.

6.3.2 Material Conformance Testing and Inspection

Due to extremely cold conditions during December and January and the fact that the conformance samples for Phases 1 and 2 of the CAMU construction met project specifications, conformance samples were collected during (instead of prior to) the final cover GCL installation and submitted to Precision Geosynthetic Laboratories, Inc. (Precision) of Anaheim, California for analysis of Free Swell (ASTM D5890), Fluid Loss (ASTM D5891), Bentonite Mass Per Unit Area (ASTM D5993), Tensile Strength (ASTM D4632), Index Flux (ASTM D5887), Internal Shear Strength (ASTM D3080), Moisture Content (ASTM D4643), Permeability (ASTM D5084-90), Peel Strength (ASTM D4632), and Thickness (ASTM D D1777). An additional 1-ft by 1-ft sample was collected from each GCL roll during installation activities and submitted to Precision for Bentonite Mass Per Unit Area and Thickness analyses. Results of the GCL laboratory testing are summarized in Table 6-2 and the location of the GCL panels are shown on Drawing No. 3. Laboratory data is included in Appendix C3.

All GCL material property conformance tests met the project specifications with the exception of moisture content. The moisture content, which exceeded the 12% called for in the specifications, reflect the fact that the GCL rolls were stored outdoors before placement. It is reasonable to expect the moisture content of the rolls to increase slightly during the time between shipment from the factory and installation. Foth & Van Dyke interprets the 12% moisture content specification as applying to the GCL as it leaves the factory rather than as stored in the field. Midessa and Foth & Van Dyke received assurance from CETCO that the moisture content observed were well within the norm and that the GCL could be installed.

Table 6-2

GCL Laboratory Conformance Testing Summary
 Modern Plating Corporation
 CAMU Closure

Sample No.	Free Swell (mL/2g)	Fluid Loss (mL)	Mass Per Unit Area (lbs/ft ²)	Tensile Strength (lbs) MD/TD	Index Flux (m ³ /m ² /sec)	Internal Shear Strength (deg.)	Moisture Content (%)	Permeability (cm/sec)	Peel Strength (lbs) MD/TD	Thickness (in)
Proj. Spec.	>24	<18	>0.75	>70	<5.0 x 10 ⁻⁸	>18	<12	<5.0 x 10 ⁻⁹	>15	>0.25
GCL-Final Cover	28.0	7.4	0.95	393/413	3.2 x 10 ⁻⁹	26	14.7	3.2 x 10 ⁻⁹	46/65	0.340
GCL-1	n/a	n/a	0.96	n/a	n/a	n/a	n/a	n/a	n/a	0.341
GCL-2	n/a	n/a	0.88	n/a	n/a	n/a	n/a	n/a	n/a	0.333
GCL-3	n/a	n/a	0.95	n/a	n/a	n/a	n/a	n/a	n/a	0.332
GCL-4	n/a	n/a	0.90	n/a	n/a	n/a	n/a	n/a	n/a	0.358
GCL-5	n/a	n/a	0.97	n/a	n/a	n/a	n/a	n/a	n/a	0.365
GCL-6	n/a	n/a	0.93	n/a	n/a	n/a	n/a	n/a	n/a	0.367
GCL-7	n/a	n/a	0.90	n/a	n/a	n/a	n/a	n/a	n/a	0.346
GCL-8	n/a	n/a	0.88	n/a	n/a	n/a	n/a	n/a	n/a	0.356
GCL-9	n/a	n/a	0.92	n/a	n/a	n/a	n/a	n/a	n/a	0.351
GCL-10	n/a	n/a	0.94	n/a	n/a	n/a	n/a	n/a	n/a	0.363
GCL-11	n/a	n/a	0.87	n/a	n/a	n/a	n/a	n/a	n/a	0.349

Table 6-2 (Continued)

Sample No.	Free Swell (mL/2g)	Fluid Loss (mL)	Mass Per Unit Area (lbs/ft ²)	Tensile Strength (lbs) MD/TD	Index Flux (m ³ /m ² /sec)	Internal Shear Strength (deg.)	Moisture Content (%)	Permeability (cm/sec)	Peel Strength (lbs) MD/TD	Thickness (in)
GCL-12	n/a	n/a	0.84	n/a	n/a	n/a	n/a	n/a	n/a	0.358
GCL-13	n/a	n/a	0.92	n/a	n/a	n/a	n/a	n/a	n/a	0.332
GCL-14	n/a	n/a	0.92	n/a	n/a	n/a	n/a	n/a	n/a	0.356
GCL-15	n/a	n/a	0.93	n/a	n/a	n/a	n/a	n/a	n/a	0.358
GCL-16	n/a	n/a	0.98	n/a	n/a	n/a	n/a	n/a	n/a	0.351
GCL-17	n/a	n/a	0.94	n/a	n/a	n/a	n/a	n/a	n/a	0.338
GCL-18	n/a	n/a	0.89	n/a	n/a	n/a	n/a	n/a	n/a	0.362
GCL-19	n/a	n/a	0.95	n/a	n/a	n/a	n/a	n/a	n/a	0.357
GCL-20	n/a	n/a	0.92	n/a	n/a	n/a	n/a	n/a	n/a	0.348
GCL-21	n/a	n/a	0.94	n/a	n/a	n/a	n/a	n/a	n/a	0.356
GCL-22	n/a	n/a	0.95	n/a	n/a	n/a	n/a	n/a	n/a	0.337
GCL-23	n/a	n/a	0.88	n/a	n/a	n/a	n/a	n/a	n/a	0.344
GCL-24	n/a	n/a	0.97	n/a	n/a	n/a	n/a	n/a	n/a	0.333
GCL-25	n/a	n/a	0.95	n/a	n/a	n/a	n/a	n/a	n/a	0.333
GCL-26	n/a	n/a	0.83	n/a	n/a	n/a	n/a	n/a	n/a	0.329

n/a = not analyzed

Prepared By: BJS1
Checked By: REM

R001867

6.3.3 GCL Deployment

During the GCL panel placement, the length, panel location, and time of deployment were recorded on a Panel Placement Form. Copies of these forms are included in Appendix C4. Panel installation was observed for the following: the proper side of the GCL panels faced upward, the GCL rolls were handled properly, wrinkles larger than 1-in high and 6-in long were removed, and that there were no visible defects in the GCL rolls. Panel thicknesses were measured in the field using a micrometer at 5 locations per GCL roll. Drawing No. 3 shows the "as installed" panel locations and panel numbers. GCL seams were constructed with a minimum 8-in overlap between panels. Powdered bentonite was sprinkled between each panel overlap at a minimum rate of ¼-pound per lineal foot of seam. Immediately after deployment, the GCL was covered by the geomembrane to provide protection from moisture as shown on Photograph 7 (Appendix A).

6.4 Geomembrane Liner Construction

6.4.1 General

The final cover geomembrane installation was also performed by Midessa and observed and documented by Foth & Van Dyke. The geomembrane material used was Solmax 440T, a 40-mil textured High Density Polyethylene (HDPE) geomembrane manufactured by Solmax International, Inc. (Solmax) of Varennes, Quebec, Canada. Geomembrane information from the manufacturer is provided in Appendix D and E. The geomembrane was installed over the GCL immediately after the GCL sampling and seaming was completed.

6.4.2 Material Conformance Testing and Inspection

Prior to the installation of the geomembrane on the final cover, a conformance sample was submitted to Precision for analyses of thickness (ASTM D 5994), asperity height (GM12), tensile strength (ASTM D638), tear resistance (ASTM D1004), puncture resistance (ASTM D4833), carbon black content (ASTM D1603), carbon black dispersion (ASTM D5596), melt flow index (ASTM D1238), and resin density (ASTM D1505). The results of the conformance tests met project specifications. Results of the tests are summarized in Table 6-3 and the laboratory data from Precision is included in Appendix E.

6.4.3 Preproduction Weld Testing

Prior to the seaming of the geomembrane panels, trial welds were performed at the beginning of each seaming event and at least once every four hours for each seaming apparatus (fusion or extrusion welder) used that day. Each seamer made at least one trial seam each day. Four samples were cut from each of the trial welds and field tested for shear and peel.

Table 6-3

**Summary of Laboratory Test Results - Geomembrane Conformance Testing
Modern Plating Corporation
CAMU Final Cover**

Property	Units	40 mil Textured HDPE Required Value	Final Cover Roll No.17269-1
A. Sheet Properties			
1. Thickness (min. avg.)	mil	38	42.2
a. Lowest Ind. for 8 Out of 10 Values	mil	36	41.9
b. Lowest Ind. for Any of 10 Values	mil	34	41.7
2. Asperity Height (min. avg.)	mil	10	18.1
3. Tensile Properties (each direction)			
a. Yield Strength (MD/TD)	lb/in.	105 min.	122/121
b. Break Strength (MD/TD)	lb/in.	75 min.	148/117
c. Elongation at Yield (MD/TD)	%	12 min.	18.5/16.4
d. Elongation at Break (MD/TD)	%	100 min.	514/443
4. Tear Resistance (MD/TD)	lb	35 min.	40/39
5. Puncture Resistance	lb	75 min.	130
6. Carbon Black Content	% Range	2-3%	2.50
7. Carbon Black Dispersion	Rating		
8 out of 10		category 1 or 2	1
All 10		category 1,2 or 3	1

Table 6-3 (Continued)

Property	Units	40 mil Textured HDPE Required Value	Final Cover Roll No.17269-1
B. Resin Properties			
1. Melt Flow Index	g/10 min.	0.4 max.	0.1956
2. Resin Density	g/cm ³	0.94 min.	0.9454

Prepared By: BJS1
Checked By: REM

MD = Machine Direction
TD = Transverse Direction

R001870

Foth & Van Dyke observed the trial welding procedures and recorded the machine number, ambient temperature, machine speed, seamer identification, date, time and field shear and peel test results on the trial weld test forms located in Appendix F2. When the trial welds met project specifications, the technician and machine were allowed to begin welding the geomembrane.

6.4.4 Geomembrane Panel Deployment and Seaming

The geomembrane panels were deployed simultaneously with the GCL panels to protect the GCL panels from the elements. Foth & Van Dyke field personnel documented the geomembrane panel installation including the observation of panel defects, tears, or other deformities, measured panel thicknesses at a minimum of five locations per roll, measured panel dimensions, and recorded panel numbers and locations. Field forms recording the panel deployment are included in Appendix F3.

Panel seaming was performed by Midessa using a hot wedge welder. Documentation of the fusion welded seaming, including seam number, seaming crew identification, welder number, date and time of seam construction, and ambient temperature were recorded by Foth & Van Dyke field personnel. The panel seaming summary forms are provided in Appendix F4. The panel seam locations were surveyed as part of the documentation survey performed by Foth & Van Dyke. Panel and seam locations recorded during the documentation survey are shown on Drawing No. 4.

Due to cold and wet conditions during the geomembrane seaming, Midessa dried the geomembrane seams with a shop-vac and heated the geomembrane ahead of the welder with a heat gun to maintain a proper sheet temperature. During periods of rain or snow, Midessa covered the welder with a portable tent. Midessa collected samples from each end the seams and field tested the weld for peel and shear so that proper welder speed and temperature settings were maintained.

6.4.5 Non-Destructive Seam Testing

Non-destructive seam testing was performed on every field welded seam. The seams were field tested by air channel or vacuum box methods and documented by Foth & Van Dyke field personnel. Non-destructive seam testing forms are located in Appendix F5.

Air channel tests were performed by sealing both ends of the test seam, installing a manometer, and pumping the air channel to a minimum of 30 pounds per square inch (psi) using an air compressor. The maximum allowable loss in pressure for a seam was 4 psi in the five minute test. The intervals tested and test results were marked on each seam and recorded by the Foth & Van Dyke QA inspector (Appendix F5). Any welds not meeting the air channel test requirements were marked for repair.

Vacuum box tests were performed on extrusion and fusion welded seams. In the few cases where vacuum box testing was performed on fusion welded seams, the excess sheet overlap on

the seams was trimmed, the test area wetted with a soap/water solution, the vacuum box placed over the test area, and a vacuum applied to the seam for a minimum of 15 seconds while observing the test area for the presence of soap bubbles. The presence of soap bubbles indicated the presence of a leak in the seam. This is the same procedures as used to vacuum box test extrusion welded seams. Test intervals were marked on seams. All leaks detected during vacuum box testing were marked for repair. Leak areas identified by air channel rate or vacuum box tests were repaired then retested with the vacuum box (Appendix F7).

6.4.6 Destructive Seam Testing

Destructive seam tests were performed on the fusion welded seams at a minimum rate of one per 500 lineal feet of fusion welded seam at locations selected by Foth & Van Dyke field personnel. Destructive test locations were recorded as part of the documentation survey performed by Foth & Van Dyke as shown on Drawing No. 4.

A destructive sample 12-in wide by 48-in long was cut by the installer and split into four 12-in by 12-in samples. The four samples were distributed as follows: one sample for field testing, one sample to be submitted to the testing laboratory, one sample for the installer's archive, and one sample for the owner's archive.

The field testing samples were analyzed for shear and peel tests on-site by the installer. Test results were recorded by Foth & Van Dyke field personnel on the Destructive Seam Sample Summary form provided in Appendix F6.

The destructive test samples were shipped to Precision's Georgia laboratory for shear and peel analyses. Results of the laboratory tests are summarized in Table 6-4 and Precision's laboratory reports are included in Appendix G. Two destructive samples, DT-1 and DT-4, did not meet project specifications. To isolate the seams which did not meet project specifications, Midessa field tested the seams which were welded before and after the seam from which the destructive sample was collected. When field peel and shear tests indicated that the seams before and after the destructive sample locations would meet project specifications, destructive samples were collected from those locations and submitted to Precision for analysis. Laboratory results from destructive samples DT-1B and DT-1A (from the seams before and after DT-1, respectively) and DT-4B and DT-4A (from the seams before and after DT-4, respectively) met the project specifications. Laboratory results for the remainder of the destructive seam test samples met project specifications. The seams between DT-1B and DT-1A and DT-4B and DT-4A were extrusion welded and vacuum box tested. One destructive sample (DT-6) was collected from an extrusion welded seam.

Table 6-4

**Destructive Seam Laboratory Test Results (ASTM D4437) - Final Cover
Modern Plating Corporation
CAMU Closure**

Sample No.	Seam No.	Peel				Shear			
		Maximum Tension		Peel Incursion (%)	Failure Mode	Maximum Tension (lb/in.)	Elongation @ Break (%)	Failure Mode	Sample Pass/Fail
		Inside (lb/in.)	Outside (lb/in.)						
DT-1	P4/P5	100	69	100	Non-FTB	128	>50	FTB	Fail
DT-1B ⁴	P2/P3	98	86	<10	FTB	136	>50	FTB	Pass
DT-1A ⁵	P1/P9	97	101	<10	FTB	130	>50	FTB	Pass
DT-2	P9/P10	94	96	<10	FTB	128	>50	FTB	Pass
DT-3	P14/P15	92	98	<10	FTB	131	>50	FTB	Pass
DT-4	P18/P21	93	81	70	FTB	126	>50	FTB	Fail
DT-4B ⁶	P18/P21	100	97	<10	FTB	126	>50	FTB	Pass
DT-4A ⁷	P18/P22	96	93	<10	FTB	125	>50	FTB	Pass
DT-5	P19/P23	98	100	<10	FTB	127	>50	FTB	Pass
DT-6 ⁸	P6/P8	---	97	<10	FTB	133	>50	FTB	Pass

Summary:

Mean	96	92	---	---	129	---	---	---
Minimum	92	69	---	---	125	---	---	---
Maximum	100	101	---	---	136	---	---	---

Table 6-4 (Continued)

Sample No.	Seam No.	Peel				Shear			
		Maximum Tension		Peel Incursion (%)	Failure Mode	Maximum Tension (lb/in.)	Elongation @ Break (%)	Failure Mode	Sample Pass/Fail
		Inside (lb/in.)	Outside (lb/in.)						

Project Specifications:

Minimum	60(F) ² /52(E) ³	60(F)/52(E)	---	FTB	80	---	FTB	---
Maximum	---	---	10	---	---	---	---	---

Prepared By: BJS1
Checked By: REM

Notes:

1. FTB = Film tear Bond
2. F = Fusion Weld
3. E = Extrusion Weld
4. DT-1B is a test of the seam welded before DT-1.
5. DT-1A is a test of the seam welded after DT-1.
6. DT-4B is a test of the seam welded before DT-4.
7. DT-4A is a test of the seam welded after DT-4.
8. DT-6 is an extrusion welded seam.

6.4.7 Repair Documentation

Repairs were completed by applying patches and extrusion welding the patches in place at locations where leaks and seaming imperfections were detected, panel imperfection observed and at destructive test locations. Each repair was assigned a number and recorded in repair summary forms (Appendix F7). All repairs were vacuum box tested using the methods described in Section 6.4.5.

As part of the repair installation activities, pipe boots were installed at each of the gas vent locations and where the Phase 1 and 2 leachate and leak detection pipes penetrated the final cover. The gas vent pipe boots were constructed as shown on Detail 2/7 of Drawing No. 7.

Appendix F7 contains the repair summary forms. The location of all repairs was recorded as part of the documentation survey performed by Foth & Van Dyke and are shown on Drawing No. 4.

6.5 Geocomposite Construction

6.5.1 General

The purpose of the geocomposite layer is to provide a preferential flow path from the final cover soils to the drainage outlets located in the final cover anchor trench for any rainfall which infiltrates the final cover soils. The geocomposite consists of layer of geonet which permits the flow of water sandwiched by two layers of non-woven geotextile which act as a filter and provide stability against sliding. Evergreen Technologies, Inc. (ETI) of Evergreen, Alabama supplied the DC4200AA geocomposite used in the final cover construction.

6.5.2 Panel Layout and Seaming

The geocomposite panels were attached by securing the panels with placing plastic ties at a maximum 5-ft interval along the length of panel seams. Any cross seams had plastic ties placed at 1-ft intervals. The fabric component of the geocomposite was lystered (heat bonded) together using a heat gun.

6.5.3 Geocomposite Conformance Testing

Prior to the geocomposite installation, conformance samples were submitted to Precision for analysis of density (ASTM D792 or D1505), melt flow index (ASTM D1238), carbon black content (ASTM D1603), and transmissivity (ASTM D4716) for the geonet properties; and transmissivity (ASTM D4716) and ply adhesion (ASTM D413) for the geocomposite properties. The manufacturer's data for the geocomposite is included in Appendix H1.

The results are summarized in Table 6-5 and the laboratory data is included in Appendix H2. Laboratory tests met the project specifications.

Table 6-5

Summary of Laboratory Results - Geocomposite Conformance Testing ¹
Modern Plating Corporation
CAMU Closure

Property	Units	Project Specifications	Test	Conformance Test Frequency	Final Cover
Geonet Properties					
Density	g/cu cm	0.90 min	ASTM D1505	100,000 sf	0.9588
Melt Flow Index	g/10 min	1.0 max	ASTM D1238	100,000 sf	0.739
Carbon Black Content	percent	2-3 range	ASTM D1603	100,000 sf	2.29
Geocomposite Properties					
Transmissivity	m ² /sec	3x10 ⁻⁵	ASTM D4716	100,000 sf	107.85
Ply Adhesion (MD/TD)	lb/in	2.0	ASTM D413 Method A	100,000 sf	MD 3.3 TD 4.9

Prepared By: BJS1
Checked By: REM

¹ Roll 0403366

MD = Machine Direction

TD = Transverse Direction

6.6 Rooting Zone Placement

6.6.1 Soil Material Properties

A 2.5-ft thick rooting zone layer consisting of clean, fine grained soil material free of rock, roots and other sharp objects was placed on top of the geocomposite. The soil used in the rooting zone construction was similar to the material used during the CAMU subbase construction. The grain size analysis (Appendix I) of rooting zone material described the soil as a brown silty clay with little fine and medium sand and trace gravel. The USCS soil classification (ASTM D2488) for the soil was CL. The off-site source for the rooting zone material was the Civil Constructors Quarry located in Freeport, Illinois.

6.6.2 Rooting Zone Drainage

The final cover anchor trench was designed to collect any water that percolates through the rooting zone soils. The rainwater percolates through the rooting zone and flows through the geocomposite to the anchor trench. The anchor trench contains a 4-in diameter slotted corrugated polyethylene collection pipe surrounded by ¾-in coarse aggregate wrapped in a non-woven geotextile. At approximately 50-ft intervals along the anchor trench, a 4-in diameter corrugated polyethylene drain pipe and tee was installed into the slotted drain pipe to

allow the water to flow to the perimeter berm drainage ditch. Rooting zone drainage details are shown on Drawing No. 6, Detail 1/6. The perimeter berm drainage ditches flow to two sedimentation basins located on the west and northeast sides of the CAMU.

A modification was made in the field which eliminated the proposed light riprap at the pipe exits on the perimeter berm and replaced the riprap with 3- to 4-in breaker run stone.

6.6.3 Rooting Zone Construction Observation

A Foth & Van Dyke resident project representative observed the placement of the rooting zone soils which were placed in a single 2.5-ft thick lift. The soils were observed to contain no roots, rocks or other sharp objects and care was taken by TERRA to mitigate potential damage to the geocomposite and geomembrane. The rooting zone was placed by pushing the full 2.5-ft thick lift thickness over the geocomposite with a LGP bulldozer. Soil placement started around the perimeter of the CAMU and proceeded toward the high points.

6.7 Topsoil Placement and Establishing Vegetation

A 6-in thick layer of topsoil was placed on top the rooting zone. The topsoil placement was observed by the Foth & Van Dyke resident project representative to be of suitable organic content. The topsoil was seeded with a combination of alta tall fescue, perennial ryegrass, creeping red fescue, oats, and winter wheat at a rate of 200 lbs per acre. The seeded areas were fertilized and mulched.

6.8 CAMU Site Security

A 6 ft high chain-link fence was constructed around the CAMU to the secure the site. Appendix M contains the details of the fence construction. The location of the fence is shown on the plat of survey drawing in Appendix J and on Drawing No. 5. Details of the security fence materials and construction are included in Appendix O.

7 Final Grades Survey

A Foth & Van Dyke registered land surveyor performed a topographic survey of the final cover grades. The final grades survey included the topography of the top of topsoil on the CAMU, the rooting zone drainage outlet locations, the perimeter berm drainage ditches, and the inlet and outlet locations of the two sedimentation basins. The final configuration for the CAMU, sedimentation basin, drainage features and the final grades for the other units closed is shown on Drawing No. 5.

8 Survey Plat for the CAMU

8.1 General

Section I, Condition No.H.5. of the April 2000 RCRA Part B Permit requires that a survey plat as specified in Condition I.H.3. be included with the closure documentation report. Section I, Condition No. H.3. requires that the survey plat indicate *the location and dimensions of the CAMU and any other hazardous waste disposal units with respect to permanently surveyed benchmarks. This plat shall be prepared and certified by a professional land surveyor.* This section describes the information and drawings provided to meet the above listed requirements.

8.2 Survey Plat and Plat Notes

On July 5, 2001 the field survey of the completed and closed CAMU was performed by Mr. Jim Prehn, Illinois registered land surveyor. Mr Brian Stanul, the resident engineer for the CAMU construction and closure assisted Mr. Prehn in the survey work. The survey plat consisted of surveying the chain-link fence which surrounds the CAMU. The chain-link fence is outside of the CAMU waste limits and was used to generate a meets and bonds survey descriptions for the CAMU. Appendix J contains two 11-in by 17-in drawings which include Drawing No. 1 - the Plat of Survey for the CAMU and Drawing No. 2 - Extent of Area Remediated.

Drawing No. 1 includes:

- ◆ Meets and bounds description of the area inside of the chain-link fence which is occupied by the CAMU Landfill.
- ◆ An Illinois registered land surveyor certification of the survey plat.
- ◆ The required survey notes from the RCRA Part B Permit Section I, Condition H. 3. and 4. which were included as follows:
 - ▶ The CAMU contains the remediation wastes generated during the closure of hazardous waste and solid waste units at the Modern Plating facility in accordance with an Illinois EPA approved closure plan (Log No. C-259-M-8).
 - ▶ The waste materials contained in the CAMU are considered RCRA hazardous wastes. They include electroplating sludges (F006), wastes with trichloroethylene (F002) and wastes containing cadmium, chromium, and cyanide.
 - ▶ Any fill material removed from the CAMU during future activities must be managed as a hazardous waste in accordance with 35 Ill. Adm. Code Subtitle G: Waste Disposal.
 - ▶ The use of the area is restricted.

- ▶ A survey plat and record of the type, location and quantity of waste materials in the CAMU have been filed with IEPA, the county, and any local zoning authority with jurisdiction over local land use.

Drawing No. 2 includes:

- ◆ The quantities of wastes which were excavated from the hazardous and solid waste management units on the Modern property.
- ◆ The locations of the other units which were closed as part of the Modern Plating remediation including Lagoons 0, 1 and 1A, the cyanide vault, Wetlands No. 1, 1A, 2 and 3 and the Shawnee building.

8.3 Documentation of the Filing of the Survey Plat

The survey plat for the CAMU as provided in Appendix J has been filed with the Stephenson County recorders office in Freeport, Illinois. The survey map was filed on July 26, 2001 by Mr. Jim Prehn, licensed land surveyor in the state of Illinois. The record data is as follows: Document No. 200100016096, Box 15, pages 111-116 (each 11" x 17" drawing was recorded as three separate 8.5" x 11" pages).

9 Closure of Wetland and Shawnee Building Soils

9.1 Wetland and the Shawnee Building Soils

Soils from four wetland areas (Wetland No.1, Wetland No. 1A, Wetland No.2, and Wetland No. 3) were excavated during the remediation activities at Modern. Drawing No. 2 of Appendix J shows the surveyed location of the wetland areas excavated.

A field investigation and analytical testing completed as part of the Corrective Measures Study (CMS) determined that remedial objectives could be met by removing the upper 2 ft of soil from the contaminated wetland areas and testing for cadmium. Sufficient remediation of wetlands would occur on removal of soils to cadmium concentrations of 200 mg/kg or less. The suspected contaminated areas were staked in the field based on the cadmium iso-concentration maps prepared for the CMS (reproduced in Appendix K for reference). The staked areas were then excavated and the base and limits of the excavation sampled to determine if the remediation objectives were met. Due to an unusually wet spring and summer, water typically entered the wetland excavation after excavation was completed.

9.1.1 Sampling and Analysis Procedures

Excavated wetland areas were sampled as per the revised Construction Quality Assurance Manual prepared for the Foth & Van Dyke resident engineer. A copy of the manual's section related to wetland and contaminated soil sampling is included in Appendix L. Samples were handled by the Foth & Van Dyke resident engineer using standard chain-of-custody procedures. The Foth & Van Dyke standard operating procedures (SOPs) for solids/semi-solids sampling and for chain-of-custody documentation are also included in Appendix L. The chain-of-custody forms and the laboratory results for each set of analysis for the wetland soils and Shawnee Building are included in Appendix M. The initial pages of Appendix M contain scaled field sketches which show the wetland and Shawnee Building soil sample locations along with the soil sample number which correspond to the numbers in the analytical laboratory reports.

The test results and soil classification of samples tested from the wetlands and Shawnee Building are summarized in Table 9-1. Analytical testing was performed by Test America, Bartlett, Illinois. Samples were delivered by the Foth & Van Dyke resident engineer to Test America laboratory typically the same day the samples were taken. For many samples Test America provided preliminary test results via fax within 24 hours of receipt of the sample at the laboratory. A field x-ray fluorescence spectrometer was used briefly during the spring of 2000 to analyze wetland areas excavated. The field instrument proved not to be cost effective and this field method was abandoned and replaced with delivering conformation samples to Test America for analysis. For cadmium Test America used Method SW 6010B, a ICP method.

Part of Foth & Van Dyke's health and safety program was to monitor for the presence of volatile organic compounds (VOCs) with a Photovac Microtip photo ionization detector (PID). The PID was primarily used to monitor the air space in the working area during the excavation, loading, hauling and disposal of the sludges and contaminated soils. As shown in Table 9-2, PID

Table 9-1
Summary of Soil Test Results
Wetland and Shawnee Building Soils

Excavation Confirmatory Sampling Data/Depth/Location**	Cadmium (mg/kg)	Soil Description (USCS Classification)
Wetland No. 1		
MP-1-6-2.5	0.73	Organic Silty Clay, Soft, Black (OL)
MP-1-10-2.5	2.7	Organic Silty Clay, Soft, Black (OL)
MP-1-13-2.5	56	Organic Silty Clay, Soft, Black (OL)
Wetland No. 1A		
WT1A-1 (2' ditch)	7.4	Organic Silty Clay, Soft, Black (OL)
WT1A-2 (2' bottom)	36	Organic Silty Clay, Soft, Black (OL)
Wetland No. 2		
WT2-1 (2' west center)	4.1	Organic Silty Clay, Soft, Black (OL)
WT2-2 (2' east center)	2.6	Organic Silty Clay, Soft, Black (OL)
WT2-3 (2' west boundary)	3.1	Organic Silty Clay, Soft, Black (OL)
WT2-4 (2' north boundary)	14	Organic Silty Clay, Soft, Black (OL)
WT2-5 (2' east boundary)	3,860	Organic Silty Clay, Soft, Black (OL)
*WT2-8 (2' southeast boundary)	1.3	Organic Silty Clay, Soft, Black (OL)
WT2-6 (2' south boundary)	120	Organic Silty Clay, Soft, Black (OL)
WT2-7 (2' south boundary)	59	Organic Silty Clay, Soft, Black (OL)
Wetland No. 3		
WT3-1 (2' north boundary)	1.4	Organic Silty Clay, Soft, Black (OL)
WT3-2 (2' north center)	0.87	Organic Silty Clay, Soft, Black (OL)
WT3-3 (2' northwest boundary)	1.8	Organic Silty Clay, Soft, Black (OL)

Table 9-1 (Continued)

Excavation Confirmatory Sampling Data/Depth/Location**	Cadmium (mg/kg)	Soil Description (USCS Classification)
WT3-4 (2' center)	4.3	Organic Silty Clay, Soft, Black (OL)
WT3-5 (2' northeast boundary)	4.7	Organic Silty Clay, Soft, Black (OL)
WT3-6 (2' southeast boundary)	2.0	Organic Silty Clay, Soft Black (OL)
WT3-7 (2' southwest boundary)	130	Organic Silty Clay, Soft Black (OL)
WT3-8 (2' south center)	28	Organic Silty Clay, Soft Black (OL)
Shawnee Building		
SHAW-1 (NE~3' B/T/O/S)	<0.63	Brown, Silty Clay with trace sand and gravel (CL)
SHAW-2 (SE~3' B/T/O/S)	<0.63	Brown, Silty Clay with trace sand and gravel (CL)
SHAW-3 (SW~3' B/T/O/S)	<0.64	Brown, Silty Clay with trace sand and gravel (CL)
SHAW-4 (NW~3' B/T/O/S)	0.64	Brown, Silty Clay with trace sand and gravel (CL)

B/T/O/S = Below Top of Slab.

*Resample of area near WT2-5 after additional excavation was completed.

**Sample locations shown on the sketches located in Appendix M.

Prepared by: BJS1
Checked by: REM

Table 9-2
Summary of PID Readings¹
Waste Excavation and Handling

Date/Time	Location	PID Reading	Construction Activity
5/23/00 - 10:15	Lagoon No. 1	3.0 (ambient) 5.0 (sludge)	Stockpiling sludge
5/23/00 - 15:00	Lagoon No. 1	0.0	Stockpiling sludge
5/24/00 - 7:15	Lagoon No. 2	0.0	Excavating sludge
5/25/00 - 8:35	Lagoon No. 2	0.7 (wet sludge) 2.5 (dry sludge)	Excavating sludge
5/25/00 - 10:45	Lagoon No. 2	1.7 (ambient) 3.3 (sludge pile)	Stockpiling sludge
5/26/00 - 7:05	Lagoon No. 2	0.3	Excavating sludge
5/30/00 - 9:30	Lagoon No. 2	16.0 ²	Excavating sludge
5/31/00 - 7:45	Lagoon No. 2	7.0 ²	Excavating sludge
6/6/00 - 8:45	Lagoon No. 2	0.0	Excavating contaminated soils
6/6/00 - 13:15	Lagoon No. 2	0.0	Excavating contaminated soils
6/7/00 - 7:25	Lagoon No. 2	0.0	Pumping water from excavation
6/9/00 - 8:00	Lagoon No. 2	0.0	Grading Phase I CAMU
7/18/00 - 16:10	Shawnee Building	0.0	Contaminated soil excavation
7/31/00 - 8:40	Lagoon No. 3	0.0	Excavating sludge
8/3/00 - 8:10	Wetland soil stockpile	0.0	Excavating contaminated soil
8/7/00 - 13:05	Lagoon No. 1	0.0	Stockpiling sludge in Lagoon No. 1
8/8/00 - 7:15	Lagoon No. 1	0.0	Stockpiling sludge in Lagoon No. 1
8/9/00 - 13:00	Lagoon No. 2	0.0	Placing sludge in CAMU Phase I
8/10/00 - 7:45	Lagoon No. 3	0.0	Excavating sludge
8/11/00 - 8:10	Lagoon No. 3	0.0	Excavating sludge
8/14/00 - 10:50	Lagoon No. 1	0.0	Stockpiling sludge from Lagoon No. 3
8/16/00 - 8:15	Lagoon No. 1	0.0	Stockpiling sludge from Lagoon No. 3

Table 9-2 (Continued)

Date/Time	Location	PID Reading	Construction Activity
8/16/00 - 14:30	Lagoon No. 3	0.0	Excavating sludge
11/7/00 - 13:05	Lagoon No. 0	0.0	Excavating sludge
11/8/00 - 10:30	Lagoon No. 0	1.7 (breathing zone) 17.5 (sludge)	Excavating sludge
11/8/00 - 15:00	Lagoon No. 0	0.0 (breathing zone) 17.6 (sludge)	Excavating sludge

¹ PID readings summarized from field notes taken by Brian Stanul, Foth & Van Dyke.

² High reading thought to be due to 100% humidity or rain.

Prepared by: BJS
Reviewed by: REM

readings in the ambient air were for the most part low or at background levels. The hydrogen cyanide detector was used primarily during the excavation of sludges from the lagoons since cyanide had been disposed in these units. Reading from the hydrogen cyanide detector are not included since hydrogen cyanide gas was not detected during remedial activities.

9.1.2 Wetland No. 1

Wetland No. 1 was excavated to a depth of 2 feet below the ground surface using a backhoe. Approximately 1,050 cy was excavated and the soils were then hauled to a stockpile on the north end of Lagoon No. 1A using an off-road truck. The soil stockpiled was covered with a tarp until it was excavated and placed in the CAMU as part of the Lagoon No. 1A remediation. Three confirmatory samples were collected from the sides and bottom of the excavation and submitted for cadmium analysis (Table 9-1). In compliance with the permit, the samples contained less than 200 mg/kg of cadmium.

9.1.3 Wetland No. 1A

Wetland No. 1A includes a portion of the drainage ditch which runs from the Modern parking lot into the wetlands between Lagoon No. 1 and 1A and a wetland area immediately below the drainage ditch outlet to the southeast and adjoining Wetland No. 1. Appendix J, Drawing No. 2 shows the location of Wetland No. 1A. Wetland No. 1A, including the ditch down stream of Lagoon No. 1A was excavated to a depth of 2 ft using a backhoe. Approximately 95 cy of contaminated soils, riprap and wetland soils were excavated and placed in the west end of the Lagoon No. 1 stockpile and placed in the CAMU during Lagoon No. 1 remedial activities. Two soil samples (one from the ditch and one from the wetland) were collected and submitted for cadmium analysis. Table 9-1 includes laboratory results which indicated the soil samples were less than 200 mg/kg for cadmium.

9.1.4 Wetland No. 2

Wetland No. 2 was excavated to a depth of 2 feet using a backhoe. Approximately 625 cy were excavated and then stacked at the south end of the excavation to dry prior to placing the soil in the north side of Phase 1 of the CAMU. Seven soil samples (WT2-1 through WT2-7) were collected from the sides and bottom of the excavation and submitted for analysis of cadmium. Table 9-1 contains the cadmium results. One sample collected from the east end of the excavation (WT2-5) indicated the presence of cadmium in excess of the 200 mg/kg cleanup objective. To further remediate this area, an additional excavation, approximately 40 ft by 15 ft by 2 ft deep (approximately 45 cy), was required in the vicinity of the soil sample. Following this additional excavation, an eighth confirmatory soil sample (WT2-8) was collected with results of cadmium concentration of 1.3 mg/kg which is below the 200 mg/kg cleanup objective. As such, permit clean-up conditions were met at wetland No. 2.

9.1.5 Wetland No. 3

Wetland No. 3 was excavated and stockpiled using the same methodology as Wetland No.2. The 1,080 cy of soil excavated was hauled from Wetland No. 3 to Phase 2 of the CAMU using an off-road truck and placed in the CAMU using a bulldozer. Eight soil samples (WT3-1 through WT3-8) were collected from the sides and bottom of the excavation and submitted for analysis of cadmium (Table 9-1). Results indicate that the permit condition, cadmium clean-up objective of residual concentrations of 200 mg/kg, was achieved.

9.1.6 Shawnee Building Soils

Approximately 30 cy of contaminated soil was excavated in the vicinity of the former Shawnee building on the south side of the Modern property. The remediation was completed by cutting and removing a section of the concrete slab measuring approximately 25 ft by 35 ft and excavating the soil below to a depth of approximately 3 ft. No water was encountered during the excavation activities. The concrete and soil were then staged at the west end of the Lagoon No. 1 stockpile.

After the excavation was completed, four confirmation samples (Shaw-1 through Shaw-4) were collected and submitted to the laboratory for cadmium analysis. Laboratory results (Table 9-1) indicated that the permit required soil cadmium clean-up level (less than 200 mg/kg) was achieved at the Shawnee building.

The approximate 30 cy of concrete and soil generated during the remediation of the Shawnee building vault was placed in the approximate center of Phase 1 of the CAMU on top of approximately 6 to 8 feet of sludge and then covered with sludge to protect the CAMU liner and cap system from puncture.

10 Backfilling and Restoration of the Lagoons, Wetlands, Shawnee Building and Other Units

Appendix J contains Drawing No. 2 which shows the areas from which wastes were removed along with the approximate volume of waste removed from each of the units described below. The subsections which follow provide a general discussion of the completed restoration and closure activities.

10.1 Wetland Soil Areas No. 1, 1A, 2 and 3

The excavated wetland areas were returned to their previous grades by backfilling the excavated areas with wetland soils from a stockpile located on the former Stephenson Service Co. property. Modern recently completed the purchase of this property located directly north of the Modern facility. The soils used for backfilling had been stockpiled during excavation of a pond completed as part of a wetland mitigation project completed by Stephenson Service Co. The stockpiled soils were organic silts and silty clays.

Wetlands No. 1, 1A, 2, and 3 were backfilled with the stockpiled soils just described. The soils were pushed, with a bulldozer, from the stockpile into Wetland No.3 and then into Wetland No.2. Later Wetlands No. 1 and 1A were backfilled by loading the soil from a temporary stockpile located to the south of Wetland No.3 into a dump truck and hauling the soil to the excavation area. A bulldozer then placed the soil in the Wetlands No. 1 and 1A which were backfilled to match existing grades.

10.2 Shawnee Building

To restore the excavation to surrounding grades, a compacted clayey-soil cover was placed in 1-ft lifts and compacted using a backhoe. The level of compaction was tested using a Troxler Model 3440 moisture/density gauge. Table 10-1 is a summary of the standard proctors completed on the backfill used for the remediated units. The density test results summarized in Table 10-2 show that the soil backfill was compacted to a minimum 95% of the standard proctor maximum density. The field test and laboratory results are included in Appendix N.

10.3 Cyanide Vault

To restore the cyanide vault excavation to surrounding grades, a compacted clayey-soil cover was placed in 1-ft lifts and compacted using a backhoe. The level of compaction was tested using a Troxler Model 3440 moisture/density gauge. The density test results summarized in Table 10-2 show the soil backfill was compacted to 95% of the standard proctor maximum density. The field test and laboratory results are included in Appendix N.

Table 10-1

**Summary of Standard Proctors for Cover Soils for the Remediated Units
Modern Plating Corporation Remediation**

Sample No.	USCS Soil Classification (ASTM D2488)	USCS Soil Group Name (ASTM D2488)	Standard Proctor (ASTM D422)
Modern-CIVIL-1	CL	Sandy Clay with Gravel	128.4 pcf @ 9.5%
Modern-CIVIL-3	CL	Sandy Clay with Gravel	112.2 pcf @ 16.2%

Note: Laboratory data sheets included in Appendix N.

Prepared By: BJS1
Checked By: REM

Table 10-2

**Summary of Density/Moisture Tests¹ on Cover Soils of the Remediated Units
Modern Plating Corporation Remediation**

Test No.	Location	Approx. Elevation (ft)	Depth of Probe	Wet Density (pcf)	Moisture Content (%)	Optimum Moisture Content (%)	Max. Dry Density (pcf)	Dry Density (pcf)	Percent Compaction
Cyanide Vault									
1	N100+40, E105+00	775	6"	135.3	9.9	9.5	128.4	123.1	95.9
Shawnee Building									
1	N96+30, E105+10	787	6"	136.1	10.1	9.5	128.4	123.6	96.3
Lagoon No. 1A									
197	N101+80, E102+80	762	6"	135.5	14.6	16.2	112.2	118.2	105.3
198	N101+65, E103+00	763	6"	132.1	14.2	16.2	112.2	115.7	103.1
199	N102+40, E102+40	763	6"	131.8	14.9	16.2	112.2	114.7	102.3
200	N101+65, E102+40	763	6"	127.5	15.4	16.2	112.2	110.5	98.5
201	N102+10, E103+05	764	6"	134.0	14.3	16.2	112.2	117.2	104.5
202	N102+10, E102+35	764	6"	133.6	15.0	16.2	112.2	116.2	103.6
203	N102+35, E102+90	765	6"	136.3	14.5	16.2	112.2	119.0	106.0
204	N101+70, E102+40	765	6"	127.1	16.5	16.2	112.2	109.1	97.2
205	N102+00, E103+00	766	6"	136.7	14.2	16.2	112.2	119.7	106.7

Table 10-2 (Continued)

Test No.	Location	Approx. Elevation (ft)	Depth of Probe	Wet Density (pcf)	Moisture Content (%)	Optimum Moisture Content (%)	Max. Dry Density (pcf)	Dry Density (pcf)	Percent Compaction
Lagoon No. 1A (Cont.)									
206	N102+00, E102+70	766	6"	134.4	14.2	16.2	112.2	117.7	104.9
207	N101+70, E103+00	767	6"	130.8	14.7	16.2	112.2	114.0	101.6
208	N102+35, E102+40	767	6"	133.6	14.3	16.2	112.2	116.9	104.2
Lagoon No. 0									
209	N101+20, E104+40	754	6"	133.0	14.2	16.2	112.2	116.5	103.8
210	N101+10, E104+25	755	6"	134.3	14.9	16.2	112.2	116.9	104.2
211	N101+00, E104+15	756	6"	132.5	14.4	16.2	112.2	115.8	103.2
212	N100+85, E104+00	757	6"	132.2	14.2	16.2	112.2	115.8	103.3
213	N100+70, E103+90	758	6"	130.0	14.9	16.2	112.2	113.1	100.8
214	N101+25, E103+90	759	6"	129.2	15.0	16.2	112.2	112.3	100.1
215	N101+25, E104+05	760	6"	129.6	15.3	16.2	112.2	112.4	100.2
216	N101+10, E104+00	761	6"	131.7	14.2	16.2	112.2	115.3	102.8
217	N101+05, E104+00	762	6"	127.4	15.1	16.2	112.2	110.7	98.7
218	N101+10, E104+25	763	6"	133.3	15.2	16.2	112.2	115.7	103.1
219	N101+10, E104+25	764	6"	129.7	16.0	16.2	112.2	111.8	99.6
220	N101+10, E104+25	765	6"	129.3	14.4	16.2	112.2	113.0	100.7
221	N101+10, E104+25	766	6"	128.3	15.1	16.2	112.2	111.5	99.4
222	N101+10, E104+25	767	6"	128.8	14.8	16.2	112.2	112.2	100.0

Table 10-2 (Continued)

Test No.	Location	Approx. Elevation (ft)	Depth of Probe	Wet Density (pcf)	Moisture Content (%)	Optimum Moisture Content (%)	Max. Dry Density (pcf)	Dry Density (pcf)	Percent Compaction
Lagoon No. 0 (Cont.)									
223	N101+10, E104+25	768	6"	126.2	14.6	16.2	112.2	110.1	98.1
224	N101+10, E104+25	769	6"	126.6	15.4	16.2	112.2	109.7	97.8

Notes:

¹ Appendix L contains field and laboratory soils data sheets.

Prepared By: BJS1
Checked By: REM

10.4 Lagoon No. 0

Restoration and closure of Lagoon No. 0 was accomplished by placing clayey-soil cover in 1-ft lifts using a bulldozer. The total thickness of compact clayey soil fill used to backfill the Lagoon No. 0 excavation exceeded 15 ft. Compaction was accomplished using a Dynapac CA15 sheepsfoot compactor. The level of compaction was tested using a Troxler Model 3440 moisture/density gauge on an approximately 50-ft grid. Table 10-1 summarizes the standard proctor test data. Table 10-2 contains density values which all exceed 95% of standard proctor maximum density. The field test results are included in Appendix N. Terra replaced the topsoil removed from the lagoon earlier back on top of the low permeability cover in a 6-in thick layer.

10.5 Lagoon No. 1A

Restoration and closure of the Lagoon 1A excavation was accomplished by compacting clayey-soil cover in 1-ft lifts using a bulldozer and compacting with a Dynapac CA15 sheepsfoot compactor. The total thickness of fill placed in Lagoon 1A was approximately 8 ft. The level of compaction was tested using a Troxler Model 3440 moisture/density gauge on an approximately 50-ft grid. Table 10-2 summarizes the density/moisture test data which contains density values which all exceed 95% of the standard proctor maximum density. The field and laboratory test results are included in Appendix N. The topsoil removed from the lagoon earlier was replaced over the low permeability cover in a 6-in thick layer.

10.6 Lagoon No. 1

After the sludge was removed, Lagoon No. 1 was closed by converting the lagoon to Sedimentation Basin No. 2. An approximately 6-ft thick cover of clayey soil was placed in the Lagoon No. 1 excavation using a backhoe and bulldozer to meet the design elevations for Sedimentation Basin No. 2.

Since the bottom elevation of the excavation was below the water table, an approximately 2-ft thick bridging layer was installed to ensure that proper compaction could be achieved. The remainder of the sedimentation basin was constructed in 1-ft thick lifts. Each lift was compacted using a Dynapac CA15 sheepsfoot compactor. Compaction was observed by the Foth & Van Dyke resident project representative. Due to the fact that the Troxler nuclear density gauge was off-site for annual maintenance and leak testing, no moisture/density test were performed on the backfill of Lagoon No. 1. During previous abandonment of the remediated units, Terra demonstrated that they were able to achieve compaction values which exceeded 95% of the standard proctor using the same equipment and procedures on the same clayey soil source. Therefore, we are confident that proper soil compaction was achieved for the Lagoon No. 1 backfill.

10.7 Outfall Pipeline (Additional Work)

The abandoning of the outfall pipeline consisted of the backfilling and compaction of the outfall pipeline excavation, the capping of the outfall pipeline at three manhole locations, the removal of above grade manhole covers, and the backfilling and compaction of the manholes. The excavation and manhole locations are shown on Drawing No. 2 of Appendix J.

The outfall pipeline excavation was backfilled using clean soils from the upper 4 ft of the excavation and clean soils from an off-site source. The excavation was backfilled in 1-ft thick lifts and compacted with a backhoe. Due to the small size of the excavation, density tests were not performed in the backfilled areas.

At the three outfall pipeline manhole locations, the above grade manhole covers were removed. The outfall pipeline was plugged with bricks and grout and the manholes were then backfilled with compacted soils.

11 Inspection of the CAMU

Section I Condition F. 1. of the April, 2000 RCRA Part B Permit requires that the components, structures and equipment at the CAMU be inspected in accordance with the approved permit application and starting at the effective date of the permit which is May 16, 2000. Inspections were to be completed in accordance with the schedule included in Appendix B of the permit and continue until the closure certification has been submitted to the IEPA.

Mr. Brian Stanul, the resident engineer for the remediation and CAMU construction completed these inspection on behalf of Modern Plating Corporation. Inspection were typically completed weekly or more frequently if significant rainfall event occurred. Appendix O contains copies of Mr. Stanul's field inspection reports. In review of these reports it is apparent that the facilities, including the CAMU preformed as designed during the remediation, CAMU construction, remediated unit closure and CAMU closure.

12 Conclusions and Desired Response

This report documents the closure of the CAMU landfill and the other remediated units at the Modern Plating Corporation Facility located at 701 South Hancock Street, Freeport, Illinois. This report, in conjunction with the report titled *Modern Plating Corporation CAMU Landfill Construction Documentation Report*, dated July 5, 2001, which documents the construction and certification of the CAMU, remediation and closure of the eight solid and hazardous waste management units specified in the final RCRA closure plan. This report and the CAMU documentation report provide the basis for the IEPA to grant closure for the facility so long-term care activities can be initiated.

Therefore, Foth & Van Dyke, on behalf of Modern, respectfully requests that the IEPA review and approve the attached Closure Documentation Report and provide Modern with site closure approval.

Appendix A
Construction Observation Photographs



Photograph 1 November 27, 2000
Description: Backfilling and compacting clayey soil cap on Lagoon No. 1A excavation.



Photograph 2 December 14, 2000
Description: Placing grading/gas venting layer sand on CAMU.



Photograph 3 December 15, 2000
Description: CAMU landfill top of sludge grades.



Photograph 4 December 26, 2000
Description: Installing gas vent piping in grading/gas venting layer.



Photograph 5

January 3, 2001

Description: Restoring Wetland No. 2.



Photograph 6

January 8, 2001

Description: Lagoon No.1 excavation restored and converted to Sedimentation Basin No. 2.



Photograph 7 January 13, 2001
Description: Placing GCL and geomembrane panels on CAMU landfill cap.



Photograph 8 January 17, 2001
Description: Deploying geocomposite on CAMU landfill cap.



Photograph 9 January 19, 2001
Description: Placing rooting zone soils for CAMU landfill final cover.



Photograph 10 January 25, 2001
Description: CAMU landfill final cover topsoil and rooting zone drainage system.



Photograph 11 May 1, 2001
Description: Restoration work partially completed for Cyanide Vault and Lagoon No. 0 (Topsoil placed and fine graded).



Photograph 12 May 1, 2001
Description: Restoration work in progress on Lagoon No. 1A (Topsoil placed and fine graded).



Photograph 13 May 1, 2001
Description: Sedimentation Basin No. 2 completed (Former location of Lagoon No. 1)



Photograph 14 July 5, 2001
Description: Restoration and revegetation of Wetlands 2 and 3 looking north.



Photograph 15 July 5, 2001

Description: Restoration of Wetland 1A and the rip rap in the ditch.



Photograph 16 July 5, 2001

Description: Restoration of Wetland No. 1.



Photograph 17 July 5, 2001
Description: Security fencing around the CAMU looking south, riprapped spill way from Sedimentation Basin No. 1 in the foreground.



Photograph 18 July 5, 2001
Description: Security fencing around the CAMU looking north along the east side of the CAMU.

Appendix B

Gas Venting System Material Information

- B1 - Grading/Gas Venting Layer Laboratory Report**
- B2 - Gas Venting System Manufacturer's Data**

Appendix B1

Grading/Gas Venting Layer Laboratory Report

PARTICLE SIZE DISTRIBUTION TEST REPORT

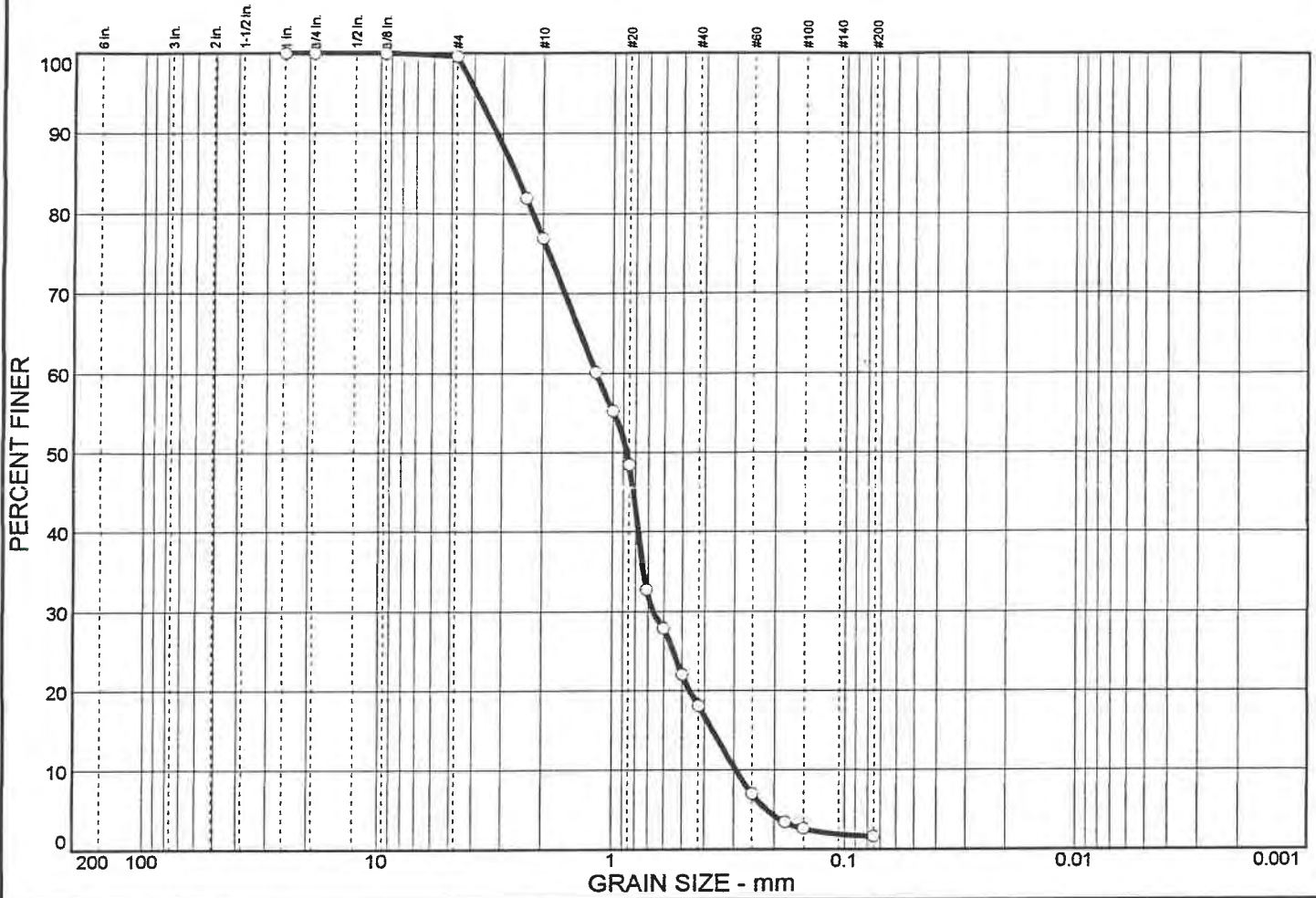

% COBBLES	% GRAVEL		% SAND			% FINES			
	CRS.	FINE	CRS.	MEDIUM	FINE	SILT	CLAY		
0.0	0.0	0.4	22.7	58.8	16.5	1.6			
LL	PL	D ₈₅	D ₆₀	D ₅₀	D ₃₀	D ₁₅	D ₁₀	C _c	C _u
X		2.63	1.18	0.871	0.668	0.369	0.294	1.29	4.00

MATERIAL DESCRIPTION	USCS	AASHTO
○ Poorly Graded Sand	SP	A-1-b

<p>Project No. 5M-0004006 Client: Foth & Van Dyke Project: Modern Plating Corporation Freeport, Illinois ○ Location: MPC-GRADING-1</p>	<p>Remarks: ○ Sample No. 5MS-00118</p>
---	--

Appendix B2

Gas Venting System Manufacturer's Data

R001911



1001 WEST ROOSEVELT ST. P.O. BOX 482 HAVYARD, IL 60033 (815) 943-5477 (800) 733-5477

April 25, 1995

Forrer Supply Co., Inc.
N117 W18388 Fulton Drive
Germantown, WI 53022

RE: Advanced Drainage Systems, Inc.
Certification of Compliance

Dear Larry:

This will certify that the 8" and 10" I.D. corrugated polyethylene pipe and fittings manufactured by Advanced Drainage Systems, Inc., comply with the requirements specified in the latest revision of AASHTO M 252 Standard Specification for Corrugated Polyethylene Drainage Tubing.

Sincerely,

Gary Ashley
Plant Manager



Gloria Ann Watson

SHGP DRAWING REVIEW

RECEIVED FROM CONTRACTOR - DATE

REVIEW IS FOR GENERAL COMPLIANCE WITH
CONTRACT DOCUMENTS.
NO RESPONSIBILITY IS ASSUMED FOR
CORRECTNESS OF DIMENSIONS OR DETAILS.

- NO EXCEPTIONS TAKEN
- MAKE CORRECTIONS NOTED
- AMEND AND RESUBMIT
- REJECTED - SEE REMARKS

FOTH & VAN DYKE

REVIEWED BY: DATE:

ADS green
number 1 in the land.

R001912



1001 WEST ROOSEVELT ST. P.O. BOX 482 HAVYARD, IL 60033 (815) 843-6477 (800) 733-6477

FORRER SUPPLY COMPANY, INC.
N117 W18388 FULTON D
GERMANTOWN, WI. 53022

RE: ADVANCED DRAINAGE SYSTEMS, INC.

Dear Larry:

This will certify that the 6" I.D. corrugated polyethylene pipe and fittings manufactured by Advanced Drainage Systems, Inc. comply with the requirements specified in the latest revision of AASHTO M 252 Standard Specification for Corrugated Polyethylene Drainage Tubing.

Sincerely,

Gary Ashley
Plant Manager

ADS green
number 1 in the land.

Appendix C

GCL Material Information

- C1 - Subgrade Acceptance Forms**
- C2 - GCL Manufacturer's QC Data and Product Information**
- C3 - GCL Laboratory Results**
- C4 - GCL Panel Placement Summary Forms**

Appendix C1

Subgrade Acceptance Forms



FINAL COVER

FORM A2

SUBGRADE ACCEPTANCE CERTIFICATE

PROJECT NAME: Madison Plating Facility

LOCATION: Freeport, IL

PROJECT No: _____

SKETCH : PARTIAL ACCEPTANCE _____ COMPLETE ACCEPTANCE X

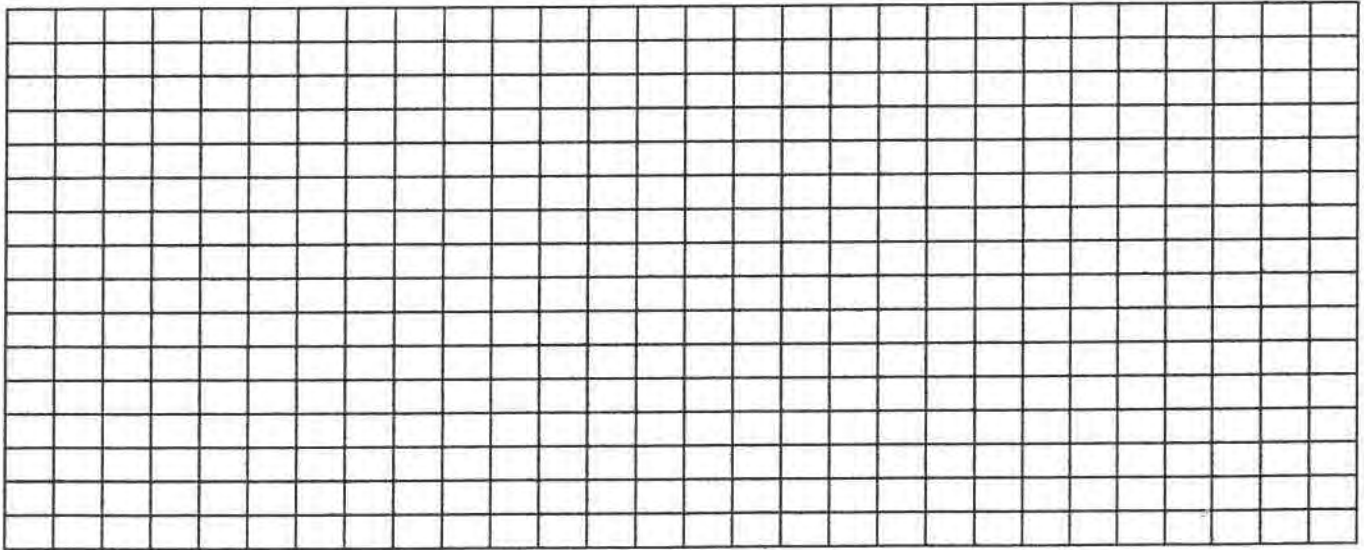

COMMENTS: Rocks, rocks, + debris were removed by Midessa, pits + low spots were also filled in prior to liner installation.

I, THE INSTALLER'S OFFICIAL REPRESENTATIVE, FIND ACCEPTABLE FOR DEPLOYMENT THE SURFACE CONDITIONS OF THE AREA DESCRIBED ABOVE.

Benjamina Velazquez [Signature] Project Manager 12/01
NAME SIGNATURE TITLE DATE

Appendix C2

GCL Manufacturer's QC Data and Product Information



R001917

COLLOID ENVIRONMENTAL TECHNOLOGIES COMPANY

P.O. Box 428 • Lovell, Wyoming 82431
(307) 548-6521 • Fax (307) 548-6413

RECEIVED
JUN 19 2000

Copy for your records

TERRA ENGINEERING

Date: June 13, 2000
PO: 00.FREEIL
Order #: 128169, 128170

Ruban Valasquaz,
Midessa Industrial Vinyl Co.
4809 West 42nd Street
Odessa, TX. 79764
915-530-3055

Dear Ruban Valasquaz,

Please find enclosed the MQA/MQC Data Package for BENTOMAT DN[✓] shipments
to Midessa Industrial Vinyl Co.. These shipments left our
CETCO - Lovell, Wy. plant on 6/9

If you have any questions regarding the enclosed QA/QC information, please contact
Mr. Moses Briseno @ 800-322-1149 (Ext: 421).

Sincerely,

[Signature]
Noe Garcia

Quality Assurance



BENTOMAT DN

MANUFACTURING QA / QC DATA PACKAGE

PROJECT NAME: Modern Plating Corporation
Freeport, IL. 60132

CUSTOMER P.O.: 00.FREEIL

PREPARED FOR: Midessa Industrial Vinyl Co.
4809 West 42nd Street
Odessa, TX. 79764
Telephone #: 915-530-3055

PREPARED BY: Noe Garcia
Quality Assurance
CETCO
P.O. Box 428
92 Hwy. 37
Lovell, Wy. 82431
Telephone #: 800-322-1149 (Ext. 423)
Fax #: (307)548-6927, (307)548-6413
E-Mail: ngarc@cetco.com

BENTOMAT DN

DAILY MANUFACTURING QA / QC DATA

FOR ALL GCL MANUFACTURED ON:

Project Name:	Modern Plating Corporation
Prepared For:	Midessa Industrial Vinyl Co.
Customer PO:	00.FREEIL
Order Number:	128169, 128170
Ship Date:	6/9

CONTENTS:

1. DAILY GCL PRODUCTION CERTIFICATION
2. NEEDLE DETECTION CERTIFICATION
3. BENTONITE CLAY CERTIFICATION
4. GCL MANUFACTURING CERTIFICATION AND TEST RESULTS
5. GCL MQA TRACKING FORM

**DAILY BENTOMAT DN PRODUCTION
PRODUCTION CERTIFICATION**

BENTOMAT DN MANUFACTURING CERTIFICATION

Project Name:	Modern Plating Corporation
Prepared For:	Midessa Industrial Vinyl Co.
Customer PO:	00.FREEIL
Order Number:	128169, 128170
Ship Date:	9-Jun

Colloid Environmental Technologies Company (CETCO) hereby affirms and certifies that all of the BENTOMAT DN manufactured in this lot achieves the physical and chemical criteria listed on the attached analysis sheet.

 Steve Wilkerson
 Production Coordinator

Subscribed and sworn to before me this 13th day of June 2000.

 Notary-Public

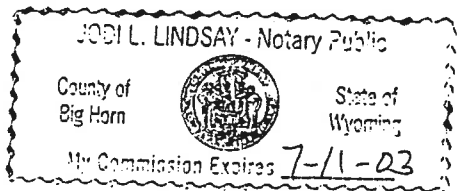

NEEDLE DETECTION CERTIFICATION

CERTIFICATION STATEMENT

Project Name:	Modern Plating Corporation
Prepared For:	Midessa Industrial Vinyl Co.
Customer PO:	00.FREEIL
Order Number:	128169, 128170
Ship Date:	9-Jun

This statement is to certify that all components of the BENTOMAT DN manufactured for the above project have been inspected continually for the presence of broken needles through the use of a magnetic removal system.

 COLLOID ENVIRONMENTAL TECHNOLOGIES CO. (CETCO)

Subscribed and sworn to before me this 13th day of June 2000.

 NOTARY PUBLIC

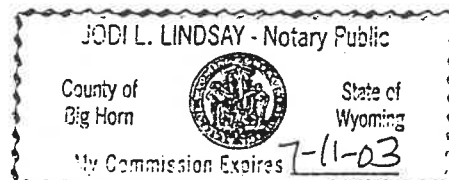

BENTONITE CLAY CERTIFICATIONS

TECHNICAL DATA SHEET

ORIGIN INFORMATION

BENTONITE

Manufacturer: **Colloid Environmental Technologies Co.**

PRODUCTION

Facility: **Colloid Environmental Technologies Co.**
92 HWY. 37
Lovell, WY 82431

Contact: **Jay Bischoff (800)-322-1159**

Brand Name: **CG 50**

BENTONITE CERTIFICATE OF ANALYSIS

CETCO
92 HWY. 37
LOVELL, WY 82431

TO: Midessa Industrial Vinyl Co.DATE: 5/1/00ATTN: Ruban Valasquaz,

Dear Customer:

The BENTONITE that is used to produce our GCL is CG 50 from CETCO, Order Number See BelowA sample of the CG 50 was tested from Lot Number 050100B and was provided the following test results below.

TEST	METHOD	REQ. SPECIFICATION	ROLL # Daily Results ACTUAL RESULTS
RET. 10 MESH	ASTM C 136	0 PERCENT	0
Bentonite Free Swell	ASTM D 5890	24 mL / 2g MIN.	24.0 [✓]
Bentonite Fluid Loss	ASTM D 5891	18.0 mL (MAX) [✓]	15.6 [✓]
Moisture	ASTM D 2216	12.0 % (MAX)	8.0
Passing 200 Mesh	ASTM D 421	1 % (Max)	0.4

We hereby certify that the results shown above represent this shipment. Tests were conducted using American Standard Test Methods and/or customer approved laboratory procedures.
Product made in the U.S.A.

Tests Conducted By: RP, SFApproved By: Noe Garcia

In any correspondence regarding this shipment, please refer to our Order Numbers listed below.
128169, 128170

BENTONITE CERTIFICATE OF ANALYSIS

CETCO

92 HWY. 37
LOVELL, WY 82431

TO: Midessa Industrial Vinyl Co.

DATE: 5/26/00

ATTN: Ruban Valasquaz,

Dear Customer:

The BENTONITE that is used to produce our GCL is CG 50 from CETCO, Order Number See Below

A sample of the CG 50 was tested from Lot Number 052600A and was provided the following test results below.

TEST	METHOD	REQ. SPECIFICATION	ROLL #	Daily Results ACTUAL RESULTS
RET. 10 MESH	ASTM C 136	0 PERCENT		0
Bentonite Free Swell	ASTM D 5890	24 mL / 2g MIN.		24.0
Bentonite Fluid Loss	ASTM D 5891	18.0 mL (MAX)		16.0
Moisture	ASTM D 2216	12.0 % (MAX)		9.2
Passing 200 Mesh	ASTM D 421	1 % (Max)		0.4

We hereby certify that the results shown above represent this shipment. Tests were conducted using American Standard Test Methods and/or customer approved laboratory procedures.
Product made in the U.S.A.

Tests Conducted By: RP, SF

Approved By: Noe Garcia

In any correspondence regarding this shipment, please refer to our Order Numbers listed below.
128169, 128170

BENTONITE CERTIFICATE OF ANALYSIS

CETCO
92 HWY. 37
LOVELL, WY 82431

TO: Midessa Industrial Vinyl Co.DATE: 5/26/00ATTN: Ruban Valasquaz,

Dear Customer:

The BENTONITE that is used to produce our GCL is CG 50 from CETCO, Order Number See BelowA sample of the CG 50 was tested from Lot Number 052600B and was provided the following test results below.

TEST	METHOD	REQ. SPECIFICATION	ROLL #	Daily Results
			ACTUAL RESULTS	
RET. 10 MESH	ASTM C 136	0 PERCENT		0
Bentonite Free Swell	ASTM D 5890	24 mL / 2g MIN.		25.0
Bentonite Fluid Loss	ASTM D 5891	18.0 mL (MAX)		15.0
Moisture	ASTM D 2216	12.0 % (MAX)		8.0
Passing 200 Mesh	ASTM D 421	1 % (Max)		0.6

We hereby certify that the results shown above represent this shipment. Tests were conducted using American Standard Test Methods and/or customer approved laboratory procedures.
Product made in the U.S.A.

Tests Conducted By: RP, SFApproved By: Noe Garcia

In any correspondence regarding this shipment, please refer to our Order Numbers listed below.
128169, 128170

BENTONITE CERTIFICATE OF ANALYSIS

CETCO
92 HWY. 37
LOVELL, WY 82431

TO: Midessa Industrial Vinyl Co.DATE: 5/26/00ATTN: Ruban Valasquaz,

Dear Customer:

The BENTONITE that is used to produce our GCL is CG 50 from CETCO, Order Number See BelowA sample of the CG 50 was tested from Lot Number 052600C and was provided the following test results below.

TEST	METHOD	REQ. SPECIFICATION	ROLL #	Daily Results ACTUAL RESULTS
RET. 10 MESH	ASTM C 136	0 PERCENT		0
Bentonite Free Swell	ASTM D 5890	24 mL / 2g MIN.		25.0
Bentonite Fluid Loss	ASTM D 5891	18.0 mL (MAX)		16.4
Moisture	ASTM D 2216	12.0 % (MAX)		8.6
Passing 200 Mesh	ASTM D 421	1 % (Max)		0.8

We hereby certify that the results shown above represent this shipment. Tests were conducted using American Standard Test Methods and/or customer approved laboratory procedures.
Product made in the U.S.A.

Tests Conducted By: RP, SFApproved By: Noe Garcia

In any correspondence regarding this shipment, please refer to our Order Numbers listed below.
128169, 128170

BENTONITE CERTIFICATE OF ANALYSIS

CETCO
92 HWY. 37
LOVELL, WY 82431

TO: Midessa Industrial Vinyl Co.DATE: 6/8/00ATTN: Ruban Valasquaz,

Dear Customer:

The BENTONITE that is used to produce our GCL is CG 50 from CETCO, Order Number See BelowA sample of the CG 50 was tested from Lot Number 060800B and was provided the following test results below.

TEST	METHOD	REQ. SPECIFICATION	ROLL #	Daily Results ACTUAL RESULTS
RET. 10 MESH	ASTM C 136	0 PERCENT		0
Bentonite Free Swell	ASTM D 5890	24 mL / 2g MIN.		25.0
Bentonite Fluid Loss	ASTM D 5891	18.0 mL (MAX)		15.8
Moisture	ASTM D 2216	12.0 % (MAX)		8.8
Passing 200 Mesh	ASTM D 421	1 % (Max)		0.4

We hereby certify that the results shown above represent this shipment. Tests were conducted using American Standard Test Methods and/or customer approved laboratory procedures.

Product made in the U.S.A.

Tests Conducted By: RP, SFApproved By: Noe Garcia

In any correspondence regarding this shipment, please refer to our Order Numbers listed below.

128169, 128170

**BENTOMAT DN
QUALITY TEST RESULTS**

BENTOMAT DN MANUFACTURING CERTIFICATION

Project Name:	Modern Plating Corporation
Prepared For:	Midessa Industrial Vinyl Co.
Customer PO:	00.FREEIL
Order Number:	128169, 128170
Ship Date:	9-Jun

CETCO hereby affirms and certifies that the BENTOMAT DN material supplied to this project will meet the physical and chemical criteria listed below.

<u>PROPERTY</u>	<u>TEST METHOD</u>	<u>MINIMUM VALUE</u>
Peel Strength	ASTM D 4632	15 lbs (65 N) ✓
Bentonite Free Swell	ASTM D 5890	24 mL / 2g MIN. ✓
Bentonite Fluid Loss	ASTM D 5891	18.0 mL (MAX) ✓
Bentonite Mass / Area	ASTM D 5993	* .75 lb/sq.ft. (Min.) ✓
Grab Strength	ASTM D 4632	150 Lbs.
Grab Elongation	ASTM D 4632	15 Percent Typical
Permeability	ASTM D 5084	5 x 10 ⁽⁻⁹⁾ cm/sec. (Max)
Index Flux	ASTM D 5887	1.0 x 10 ⁽⁻⁸⁾ m(3)/m(2)/sec. (max.)

* Reported at 0 % moisture content.

GAI Lab Accredited Test Methods were followed during conformance testing for:

ASTM D 4632 - Grab Strength and Grab Elongation.

ASTM D 5887 - Index Flux.

ASTM D 5993 - Bentonite Mass/Area.



[Signature]
Colloid Environmental Technologies Co. (CETCO)

Subscribed and sworn to before me this 13th day of June 2000.

[Signature]
Notary Public

JODI L. LINDSAY - Notary Public

County of Big Horn State of Wyoming

My Commission Expires 7-11-03

000000 000000
000000 000000

LOVELL ENVIRONMENTAL TECH CO

TOP QUALITY DATA

LOVELL AMERICAN COLLOID

SHIP TO: MOBILE FLA
701 S. HAN
FREEPORT

ORDER # 000126159

MATERIAL	LOT No.	ROLL No	BENTONITE MASS/AREA 0.75 lb/sqft ASTM D 5993	GRAB STRENGTH 1501be marv ASTM D 4632	PEEL STRENGTH 15 lbs ASTM D 4532
LO-BENTOMAT DN	200024LO	00002151	.97	304.00	35.70
LO-BENTOMAT DN	200024LO	00002150	.97	304.00	35.70
LO-BENTOMAT DN	200024LO	00002159	.97	304.00	35.70
LO-BENTOMAT DN	200024LO	00002157	.97	304.00	35.70
LO-BENTOMAT DN	200024LO	00002155	.97	304.00	35.70
LO-BENTOMAT DN	200022LO	00001792	.98	258.90	38.70
LO-BENTOMAT DN	200022LO	00001710	1.07	325.20	23.30
LO-BENTOMAT DN	200022LO	00001709	1.07	325.20	23.30
LO-BENTOMAT DN	200022LO	00001708	1.07	325.20	23.30
LO-BENTOMAT DN	200022LO	00001707	1.07	325.20	23.30
LO-BENTOMAT DN	200022LO	00001705	1.07	325.20	23.30
LO-BENTOMAT DN	200022LO	00001705	1.07	325.20	23.30
LO-BENTOMAT DN	200022LO	00001704	1.07*	325.20*	23.30*
LO-BENTOMAT DN	200019LO	00001404	.94*	259.50	37.00*
LO-BENTOMAT DN	200019LO	00001402	1.04	259.50	35.30

NOTE:

An asterisk indicates the actual test done on the roll and the roll tested.
If an asterisk is not present, test results are based on the previous roll tested.
Mass/Area and Moisture content are tested a minimum of every 40,000sf.
Grab Strength is tested a minimum of every 200,000sf.
Peel Strength is tested a minimum of every 40,000sf.
Bentonite Mass/Area is reported at 9% moisture content.
Grab Elongation is tested a minimum of every 200,000sf.

*** End of Report ***

R001933

DATE: 11/11/77
TIME: 11:22

LOVELL AMERICAN COLLOID

DCI QUALITY DATA

LOVELL AMERICAN COLLOID

SHIP TO: MODERN FLA
701 S. HAN
FREEPORT

ORDER # 000128170

MATERIAL	LOT No.	ROLL No	BENTONITE MASS/AREA 0.75 lb/sqft ASTM D 5453	GRAB STRENGTH 150lbs max ASTM D 4612	PEEL STRENGTH 15 lbs ASTM D 4532
LO-BENTOMAT DN	200023LO	00001798	.98	258.90	38.70
LO-BENTOMAT DN	200022LO	00001796	.98	258.90	38.70
LO-BENTOMAT DN	200022LO	00001755	.98	258.90	38.70
LO-BENTOMAT DN	200022LO	00001754	.98	258.90	38.70
LO-BENTOMAT DN	200022LO	00001753	.98	258.90	38.70
LO-BENTOMAT DN	200022LO	00001750	.98	258.90	38.70
LO-BENTOMAT DN	200022LO	00001789	.98	258.90	38.70
LO-BENTOMAT DN	200022LO	00001788	.98	258.90	38.70
LO-BENTOMAT DN	200022LO	00001787	.98	258.90	38.70
LO-BENTOMAT DN	200022LO	00001786	.98	258.90	38.70
LO-BENTOMAT DN	200022LO	00001785	.98*	258.90*	38.70*
LO-BENTOMAT DN	200022LO	00001784	1.04	311.80	40.90
LO-BENTOMAT DN	200022LO	00001739	.98	311.80	50.70
LO-BENTOMAT DN	200022LO	00001712	1.07	325.20	23.30
LO-BENTOMAT DN	200022LO	00001711	1.07	325.20	23.30

NOTE:

An asterisk indicates the actual test done on the roll and the roll tested.
If an asterisk is not present, test results are based on the previous roll tested.
Mass/Area and Moisture content are tested a minimum of every 40,000sf.
Grab Strength is tested a minimum of every 200,000sf.
Peel Strength is tested a minimum of every 40,000sf.
Bentonite Mass/Area is reported at 0% moisture content.
Grab Elongation is tested a minimum of every 200,000sf.

*** End of Report ***

BENTOMAT DN MQA TRACKING FORMS

QCCT#TFL QCT#TFL
6/12/00 10:07:10

COLLOID ENVIRONMENTAL TECH CO
GCL MQA/MQC TRACKING FORM

PAGE: 1

SHIP TO: MODERN PLATING CORPORATION
701 S. HANCOCK
FREEPORT IL

ORDER NUMBER 000128169

ROLL#	MATERIAL	ROLL LENGTH	SQUARE FEET	ROLL WEIGHT	GEOTEXTILE TOP LOT#	GEOTEXTILE TOP ROLL#	GEOTEXTILE BOTTOM LOT#	GEOTEXTILE BOTTOM ROLL#	CLAY LOT#
LOT# 200019L0									
00001402	L0-BENTOMAT DN	150	2100	3015	6091006A		8843670A		050100B
00001404	L0-BENTOMAT DN	150	2100	3024	6091006A		8843670A		050100B
LOT# 200022L0									
00001704	L0-BENTOMAT DN	150	2100	3095	6091004A		8843758A		052600A
00001705	L0-BENTOMAT DN	150	2100	3076	6091004A		8843758A		052600A
23 00001706	L0-BENTOMAT DN	150	2100	3059	6091004A		8843758A		052600A
00001707	L0-BENTOMAT DN	150	2100	3053	6091004A		8843758A		052600A
00001708	L0-BENTOMAT DN	150	2100	3050	6091004A		8843758A		052600A
00001709	L0-BENTOMAT DN	150	2100	3049	6091004A		8843758A		052600A
00001710	L0-BENTOMAT DN	150	2100	3034	6091004A		8843758A		052600A
00001792	L0-BENTOMAT DN	150	2100	2927	6090976A		K911094A		052600C
LOT# 200024L0									
00002156	L0-BENTOMAT DN	150	2100	3015	8821074A		114837AA		060800B
00002157	L0-BENTOMAT DN	150	2100	2994	8821074A		114837AA		060800B
00002159	L0-BENTOMAT DN	150	2100	2957	8821074A		M343891A		060800B
00002160	L0-BENTOMAT DN	150	2100	2936	8821074A		M343891A		060800B
00002161	L0-BENTOMAT DN	150	2100	2955	8821074A		M343891A		060800B

TOTAL SQUARE FEET.....

31,500

TOTAL PAGES 1

R001936

QCGHTF1 QCTHTF1
6/12/00 10:07:27

COLLOID ENVIRONMENTAL TECH CO
GCL MQA/MQC TRACKING FORM

PAGE: 1

SHIP TO: MODERN PLATING CORPORATION
701 S. HANCOCK
FREEPORT IL

ORDER NUMBER 000128170

ROLL#	MATERIAL	ROLL LENGTH	SQUARE FEET	ROLL WEIGHT	GEOTEXTILE TOP LOT#	GEOTEXTILE TOP ROLL#	GEOTEXTILE BOTTOM LOT#	GEOTEXTILE BOTTOM ROLL#	CLAY LOT#
LOT# 200022L0									
00001711	LO-BENTOMAT DN	150	2100	3029	6091004A		B843596A		052600A
00001712	LO-BENTOMAT DN	150	2100	3034	8820668A		B843596A		052600A
00001739	LO-BENTOMAT DN	150	2100	2981	8821206A		B843669A		052600B
00001784	LO-BENTOMAT DN	150	2100	2928	6090976A		B843760A		052600B
00001785	LO-BENTOMAT DN	150	2100	2969	6090976A		B843760A		052600C
24 00001786	LO-BENTOMAT DN	150	2100	2913	6090976A		B843760A		052600C
00001787	LO-BENTOMAT DN	150	2100	2917	6090976A		B843760A		052600C
00001788	LO-BENTOMAT DN	150	2100	2926	6090976A		B843760A		052600C
00001789	LO-BENTOMAT DN	150	2100	2923	6090976A		B843760A		052600C
00001790	LO-BENTOMAT DN	150	2100	2943	6090976A		B843760A		052600C
00001793	LO-BENTOMAT DN	150	2100	2931	6090976A		K911094A		052600C
00001794	LO-BENTOMAT DN	150	2100	2912	6090976A		K911094A		052600C
00001795	LO-BENTOMAT DN	150	2100	2916	6090976A		K911094A		052600C
00001796	LO-BENTOMAT DN	150	2100	2925	6090976A		K911094A		052600C
LOT# 200023L0									
00001798	LO-BENTOMAT DN	150	2100	2738	6090976A		K911094A		052600C

TOTAL SQUARE FEET.....

31,500

TOTAL PAGES 1

R001937

May 17, 2000

Benjamin Velasquez
Midessa Industrial Vinyl Co.
4809 W. 42nd
Odessa, TX 79764

RE: Modern Plating Site

Dear Benjamin:

This letter is to certify that CETCO's Geosynthetic Clay Liner will meet the specifications in the following Certified Property Sheet for Bentomat DN. CETCO furnished several clarifications with our materials quote, those clarifications are also attached.

We are enclosed our GCL Installation Guideline. Section 6 describes anchor details, Section 8, Liner Penetration, Section 9 Repair Procedures.

Storage: GCL rolls should be stored in a dry, flat area, stacked no higher than four rolls high on pallets and covered with a tarp.

If you have any questions, please feel free to call me.

Sincerely,

Steve Fishman
Regional Manager

SHOP DRAWING REVIEW

RECEIVED FROM CONTRACTOR - DATE
REVIEW IS FOR GENERAL COMPLIANCE WITH CONTRACT DOCUMENTS. NO RESPONSIBILITY IS ASSUMED FOR CORRECTNESS OF DIMENSIONS OR DETAILS.
<input type="checkbox"/> NO EXCEPTIONS TAKEN <input type="checkbox"/> MAKE CORRECTIONS NOTED <input type="checkbox"/> AMEND AND RESUBMIT <input type="checkbox"/> REJECTED - SEE REMARKS
FOOTH & VAN DYKE
REVIEWED BY: _____ DATE: _____



Bentomat® DN Certified Properties

Bentomat "DN" is a reinforced GCL consisting of a layer of sodium bentonite between two geotextiles, which are needlepunched together.

MATERIAL PROPERTY	TEST METHOD	TEST FREQUENCY, ft ² (m ²)	CERTIFIED VALUES
Bentonite Swell Index ¹	ASTM D 5890	1 per 50 tons	24 mL/2g min.
Bentonite Fluid Loss ¹	ASTM D 5891	1 per 50 tons	18 mL max.
Bentonite Mass/Area ²	ASTM D 5993	40,000 ft ² (4,000 m ²)	0.75 lb/ft ² (3.6 kg/m ²)
GCL Grab Strength ³	ASTM D 4632	200,000 ft ² (20,000 m ²)	150 lbs (400 N)
GCL Peel Strength ³	ASTM D 4632	40,000 ft ² (4,000 m ²)	15 lbs (65 N)
GCL Index Flux ⁴	ASTM D 5887	Weekly	1 x 10 ⁻⁸ m ³ /m ² /sec
GCL Permeability ⁴	ASTM D 5084	Weekly	5 x 10 ⁻⁹ cm/sec
GCL Hydrated Internal Shear Strength ⁵	ASTM D 5321	Periodic	500 psf (24 kPa) typical

- Notes:**
- ¹ Bentonite property tests performed at CETCO's bentonite processing facility before shipment to CETCO's GCL production facilities.
 - ² Bentonite mass/area reported at 0 percent moisture content.
 - ³ All tensile testing is performed in the machine direction, with results as minimum average roll values unless otherwise indicated.
 - ⁴ Index flux and permeability testing with deaired distilled/deionized water at 80 psi (551 kPa) cell pressure, 77 psi (531 kPa) headwater pressure and 75 psi (517 kPa) tailwater pressure. Reported value is equivalent to 925 gal/acre/day. This flux value is equivalent to a permeability of 5x10⁻⁹cm/sec for typical GCL thickness. This flux value should not be used for equivalency calculations unless the gradients used represent field conditions. A flux test using gradients that represent field conditions must be performed to determine equivalency. The last 20 weekly values prior the end of the production date of the supplied GCL may be provided.
 - ⁵ Peak value measured at 200 psf (10 kPa) normal stress. Site-specific materials, GCL products, and test conditions must be used to verify internal and interface strength of the proposed design.

CETCO uses the following test methods instead of the ones listed in Table 1: R001941

Free Swell	ASTM D 5890
Fluid Loss	ASTM D 5891
Bentonite Mass/Unit Area	ASTM D 5993
Permeability	ASTM D 5084

CETCO reports Hydrated Internal Shear Strength using ASTM D 5321, but our certified value is 500 psf (24 kPa) typical.

Installation Guidelines

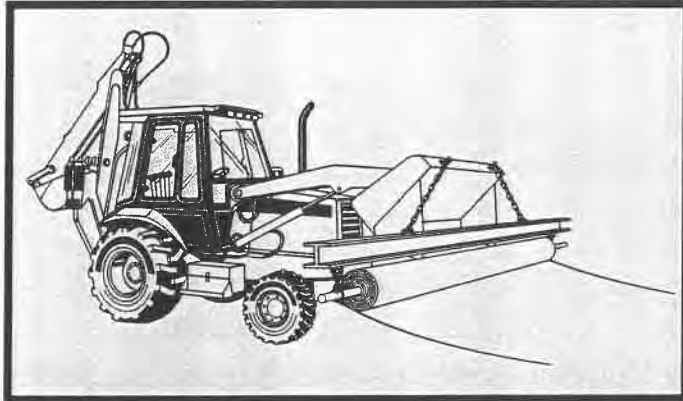

BENTOMAT[®] **CLAYMAX[®]**

Geosynthetic Clay Liner

1 Introduction

- 1.1 This document provides procedures for the installation of CETCO's GCLs in a manner that maximizes safety, efficiency, and the physical integrity of the GCL.
- 1.2 These guidelines are based upon several years of experience at a variety of sites and should be generally applicable to any type of lining project using CETCO's GCLs. The user should contact CETCO if it is believed that conditions at a particular site warrant modifications to these guidelines.
- 1.3 The performance of the GCL is wholly dependent on the quality of its installation. It is the installer's responsibility to adhere to these guidelines, and to the project specifications and drawings, as closely as possible. It is the engineer's and owner's responsibility to provide construction quality assurance (CQA) for the installation, to ensure that the installation has been executed properly. This document covers only installation procedures.

2 Equipment Requirements

- 2.1 CETCO GCLs are delivered in rolls weighing 2,500-2,700 lbs. (1,225 - 1,140 kg). It is necessary to support this weight using an appropriate core pipe as indicated in Table 1. For any installation, the core pipe must not deflect more than 3 inches (75 mm) as measured from end to midpoint when a full GCL roll is lifted.

Table 1. Core Pipe Requirements

Product	Nominal GCL Roll Size, W x L Ft. (m)	Typical GCL Roll Wt., lbs. (kg)	Interior Core Size, in. (mm)	Core Pipe Length x Diameter, ft. x in. (m x mm)	Minimum Core Pipe Strength
Bentomat CL, ST, DN	15 x 150 (4.6 x 45)	2,700 (1,225)	4 (100)	18 x 3 (5.5 x 75)	XXH
Claymax 200R, 600CL	13.8 x 125 (4.2 x 38)	2,500 (1,140)	4 (100)	16 x 3 (4.9 x 75)	XXH

- 2.2 Lifting chains or straps appropriately rated, should be used in combination with a spreader bar made from an I-beam as shown in the cover illustration. The spreader bar ensures that the lifting chains or straps do not chafe against the ends of the GCL roll, allowing it to rotate freely during installation.
- 2.3 A front end-loader, backhoe, dozer, or other equipment can be utilized with the spreader bar and core bar. Alternatively, a forklift with a "stinger" attachment may be used for on-site handling and, in

certain cases, installation. A forklift without a stinger attachment should not be used to lift or handle the GCL rolls. Stinger attachments specially fabricated to fit various forklift makes and models are available through CETCO.

- 2.4 When installing over certain geosynthetic materials, a 4-wheel, all-terrain vehicle (ATV) can be used to deploy the GCL from behind. An ATV can be driven directly on the GCL provided that no sudden stops, starts, or turns are made.
- 2.5 Additional equipment needed for installation of CETCO's GCLs includes:
- Utility knife and spare blades (for cutting the GCL).
 - Granular bentonite or bentonite mastic (for overlapped seams of GCLs with needle-punched, non-woven geotextiles and for sealing around structures and details). Both are available from CETCO.
 - Waterproof tarpaulins (for temporary cover on installed material as well as for stock-piled rolls).
 - Optional chalk line marker to simplify bentonite placement at seams (when installing a GCL with needlepunched, non-woven geotextile components).
 - Optional flat-bladed vise grips (for positioning the GCL panel by hand).

3 Subgrade Preparation

- 3.1 Subgrade surfaces consisting of granular soils or gravel may not be acceptable due to their large void fraction and puncture potential. In high head (greater than one foot) applications subgrade soils should possess a particle size distribution such that at least 80 percent of the soil is finer than a #60 sieve (0.250 mm).
- 3.2 When the GCL is placed over an earthen subgrade, the subgrade surface must be in accordance with the project specifications. Engineer's approval of the subgrade must be obtained prior to installation. The finished surface should be firm and unyielding, without abrupt elevation changes, voids, cracks, ice, or standing water.
- 3.3 The subgrade surface must be smooth and free of vegetation, sharp-edged rocks, stones, sticks, construction debris, and other foreign matter that could contact the GCL. The subgrade should be rolled with a smooth-drum compactor to remove any wheel ruts, footprints, or other abrupt grade changes. Furthermore, all protrusions extending more than 0.5 inch (12 mm) from the subgrade surface shall either be removed, crushed, or pushed into the surface with a smooth-drum compactor. The GCL may be installed on a frozen subgrade, but the subgrade soil in the unfrozen state should meet the above requirements.

4 Unloading

- 4.1 In most cases, CETCO GCLs are delivered on flatbed trucks. To unload the rolls from the flatbed, insert the core pipe through the roll. This may require removal of the core plug, which should be replaced after the roll is unloaded. Secure the lifting straps or chains to each end of the core pipe, and to the spreader bar mounted on the lifting equipment. Hoist the roll straight up; make sure its weight is evenly distributed so that it does not tilt or sway when lifted.
- 4.2 CETCO GCLs are also delivered in closed shipping containers. To remove the roll from the container, it is best to utilize a forklift mounted with a “stinger” attachment. Guide the stinger as far as possible through the core and lift the roll up and out of the container.

5 Installation

- 5.1 GCL rolls should be taken to the working area of the site in their original packaging. Prior to deployment, the packaging should be carefully removed without damaging the GCL. The orientation of the GCL (i.e., which side faces up) may be important if the GCL has two different geotextiles. Unless otherwise specified, however, the GCL should be installed such that the product name printed on one side of the GCL faces up.
- 5.2 Equipment which could damage the GCL should not be allowed to travel directly on it. Acceptable installation, therefore, may be accomplished such that the GCL is unrolled in front of the backwards-moving equipment (Figure 1). If the installation equipment causes rutting of the subgrade, the subgrade must be restored to its originally accepted condition before placement continues.

Figure 1. Typical Bentomat®/Claymax® installation strategy

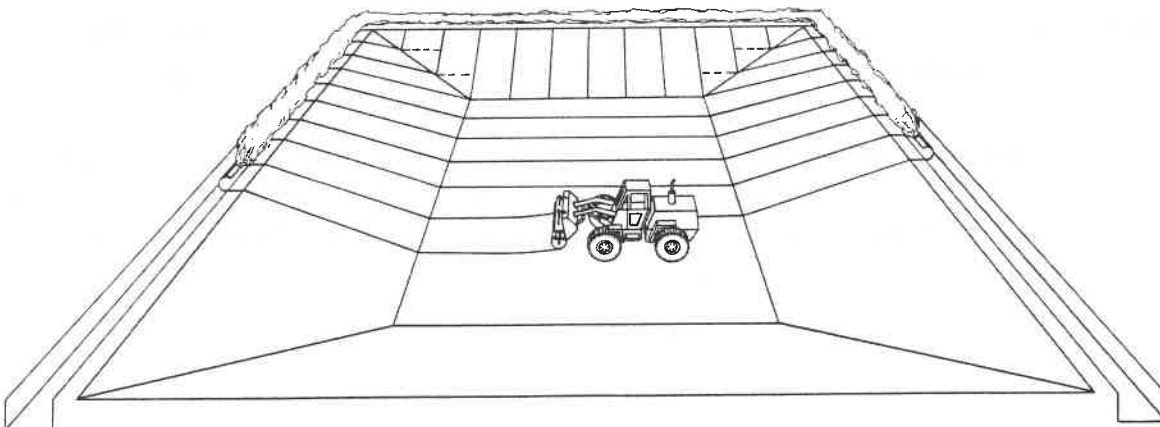

- 5.3 GCL rolls should not be released on the slope and allowed to unroll freely by gravity.
- 5.4 Care must be taken to minimize the extent to which the GCL is dragged across the subgrade in order to avoid damage to the bottom surface of the GCL. A temporary geosynthetic subgrade covering commonly known as a slip sheet or rub sheet may be used to reduce friction damage during placement.
- 5.5 The GCL should be placed so that seams are parallel to the direction of the slope. End-of-roll seams should also be located at least 3 ft. (1 m) from the toe and crest of slopes steeper than 4H:1V.
- 5.6 All GCL panels should lie flat on the underlying surface, with no wrinkles or folds, especially at the exposed edges of the panels.
- 5.7 The GCL should not be installed in standing water or during rainy weather. Only as much GCL shall be deployed as can be covered at the end of the working day with soil, a geomembrane, or a temporary waterproof tarpaulin. The GCL shall not be left uncovered overnight. If the GCL is hydrated when no confining stress is present, it may be necessary to remove and replace the hydrated material. The project engineer and CQA inspector should be consulted for specific guidance if premature hydration occurs.
- 5.8 In hot weather conditions, Claymax must be covered with a soil layer within eight hours of deployment.

6 Anchorage

- 6.1 If required by the project drawings, the end of the GCL roll should be placed in an anchor trench at the top of a slope. The front edge of the trench should be rounded to eliminate any sharp corners that could cause excessive stress on the GCL. Loose soil should be removed or compacted into the floor of the trench.
- 6.2 Sufficient anchorage may alternately be obtained by extending the end of the GCL roll back from the crest of the slope. The length of this "runout" anchor is project-specific.
- 6.3 If a trench is used for anchoring the end of the GCL, soil backfill should be placed in the trench to provide resistance against pullout. The size and shape of the trench, as well as the appropriate backfill procedures, should be in accordance with the project drawings and specifications. Typical dimensions are shown in Figure 2.

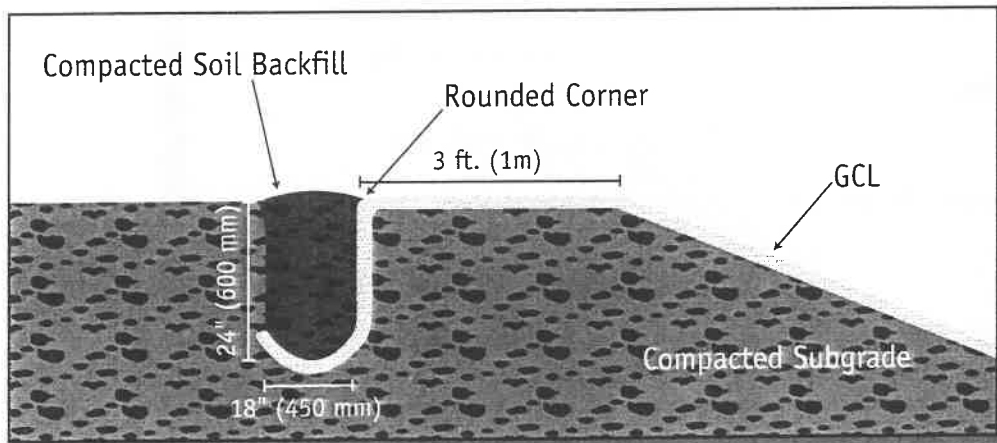
Figure 2. Typical anchor trench design

- 6.4 The GCL should be placed in the anchor trench such that it covers the entire trench floor but does not extend up the rear trench wall.

7 Seaming

- 7.1 GCL seams are constructed by overlapping their adjacent edges. Care should be taken to ensure that the overlap zone is not contaminated with loose soil or other debris. Supplemental bentonite is required for CETCO Bentomat GCLs but not Claymax 200R or 600CL.
- 7.2 Unless otherwise specified, the minimum dimension of the longitudinal overlap should be 6 inches (150 mm). End-of-roll overlapped seams should be similarly constructed, but the minimum overlap should measure 24 inches (600 mm).
- 7.3 Seams at the ends of the panels should be constructed such that they are shingled in the direction of the grade to prevent the potential for runoff flow to enter the overlap zone. End panel overlap seams on slopes are permissible, provided adequate slope stability analysis has been conducted (i.e. the GCL is not expected to be in tension).
- 7.4 Bentonite-enhanced seams are constructed first by overlapping the adjacent panels as instructed above, exposing the underlying edge, and then applying a continuous bead or fillet of granular sodium bentonite (supplied with the GCL) along a zone defined by the edge of the underlying panel and the 6-inch (150 mm) line (Figure 3). The minimum application rate at which the bentonite is applied is one quarter pound per lineal foot (0.4 kg/m).

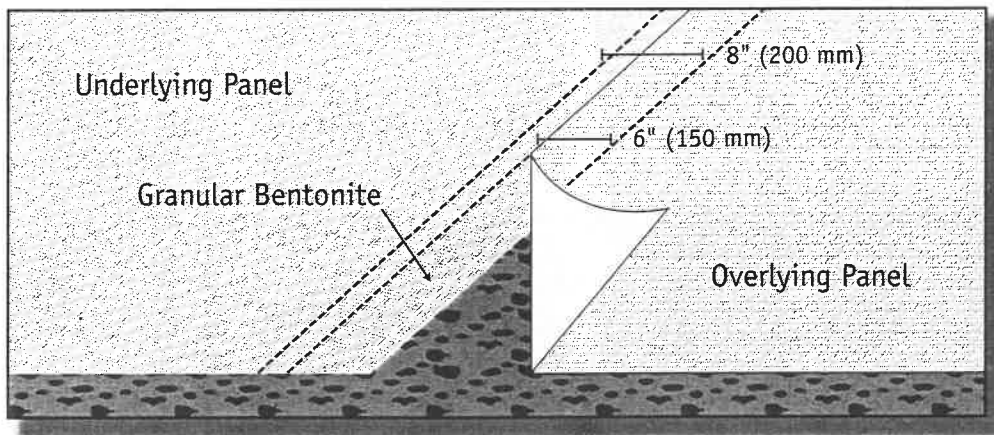
Figure 3. Bentonite-enhanced overlapped seam

8 Sealing Around Penetrations and Structures

- 8.1 Cutting the GCL should be performed using a sharp utility knife. Frequent blade changes are recommended to avoid irregular tearing of the geotextile components of the GCL during the cutting process.
- 8.2 The GCL should be sealed around penetrations and structures embedded in the subgrade in accordance with Figures 4 through 6. Granular bentonite or a bentonite mastic shall be used liberally (approx. 2 lbs./ln ft. or 3 kg/m) to seal the GCL to these structures.

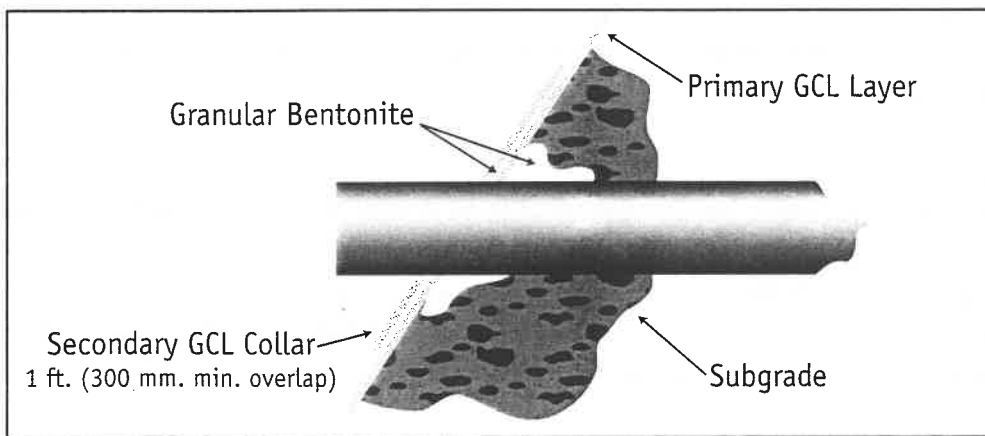
Figure 4a. Cross-section of a horizontal pipe penetration

- 8.3 When the GCL is placed over an earthen subgrade, a “notch” should be excavated into the subgrade around the penetration (Figure 4a). The notch should then be backfilled with granular bentonite or bentonite mastic.

Figure 4b. Isometric view of a completed horizontal pipe penetration

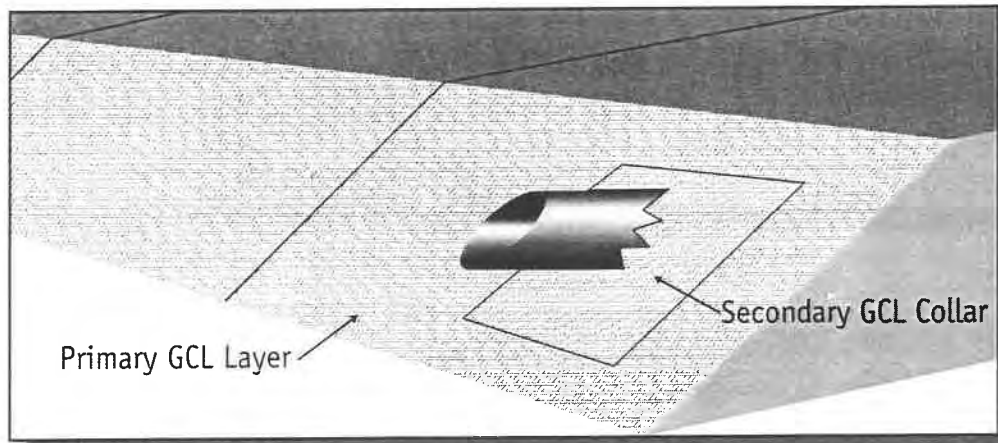

- 8.4 A secondary collar of GCL should be placed around the penetration as shown in Figure 4b. It is helpful to first trace an outline of the penetration on the GCL and then cut a “star” pattern in the collar to enhance the collar’s fit to the penetration.

Figure 5a. Cross-section of a vertical penetration

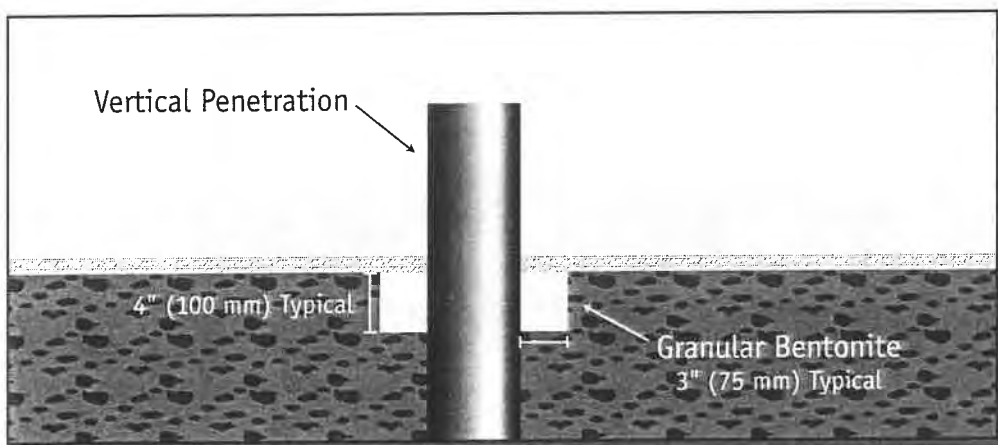

- 8.5 Vertical penetrations are prepared by notching into the subgrade as shown in Figure 5a. The penetration is completed with two separate pieces of GCL as shown in Figure 5b. A secondary collar is optional in this case.

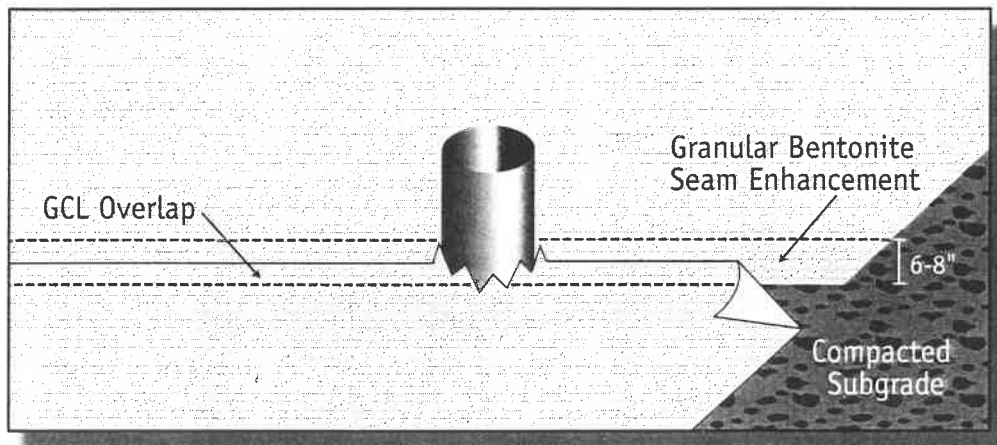
Figure 5b. Isometric view of the completed vertical penetration

- 8.6 When the GCL is terminated at a structure or wall that is embedded into the subgrade, the subgrade should be notched as described in sections 8.3 and 8.5. The notch is filled with granular bentonite, and the GCL should be placed over the notch and up against the structure (Figure 6). The connection to the structure can be accomplished by placement of soil or stone backfill in this area.

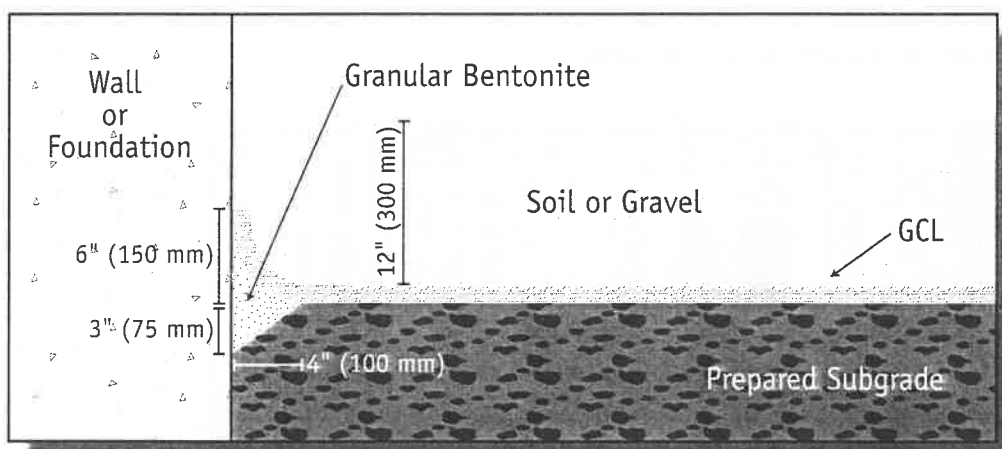
Figure 6. Cross-section of GCL seal against an embedded structure or wall

9 Damage Repair

- 9.1 If the GCL is damaged (torn, punctured, perforated, etc.) during installation, it may be possible to repair it by cutting a patch to fit over the damaged area (Figure 7). The patch should be obtained from a new GCL roll and should be cut to size such that a minimum overlap of 12 inches (300 mm)

is achieved around all parts of the damaged area. Granular bentonite or bentonite mastic should be applied around the damaged area prior to placement of the patch. It may be necessary to use an adhesive such as wood glue to affix the patch in place so that it is not displaced during cover placement. Smaller patches also may be tucked under the damaged area to prevent patch movement.

Figure 7. Damage repair by patching

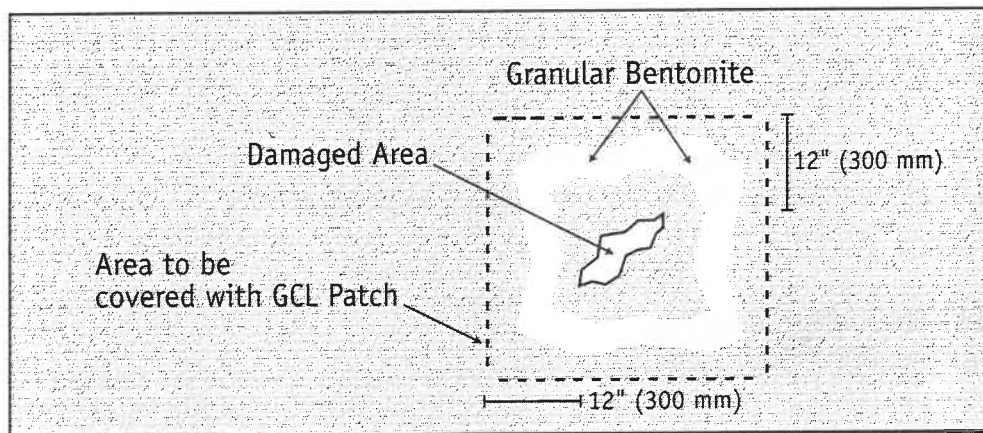

10 Cover Placement

- 10.1 Cover soils should be free of angular stones or other foreign matter that could damage the GCL. Cover soils should be approved by the Engineer with respect to particle size, uniformity, and chemical compatibility. Consult your CETCO representative if cover soils with high concentrations of calcium (e.g., limestone, dolomite) are present.
- 10.2 Recommended cover soils typically have a particle size distribution ranging between fines and 1 inch (25 mm).
- 10.3 Soil cover shall be placed over the GCL using construction equipment that minimizes stresses on the GCL. A minimum thickness of 1 foot (300 mm) of cover should be maintained between the equipment tires/tracks and the GCL at all times during the covering process. In frequently trafficked areas or roadways, a minimum thickness of 2 feet (600 mm) is required.
- 10.4 The final thickness of soil cover on the GCL varies with the application. A minimum cover layer must be at least 1 foot (300 mm) thick to provide confining stress to the GCL and prevent damage by equipment, erosion, etc.
- 10.5 Soil cover should be placed in a manner that prevents the soil from entering the GCL overlap zones. Soil cover should be pushed up slopes, not down slopes, to minimize tensile forces on the GCL.

- 10.6** When a textured geomembrane is installed over the GCL, a temporary geosynthetic covering known as a slip sheet or rub sheet should be used to minimize friction during placement and to allow the textured geomembrane to be more easily moved into its final position.

11 Hydration

- 11.1** In cases where the containment of non-aqueous liquids is required, it may be necessary to hydrate the covered GCL with water prior to use. Hydration is usually accomplished by natural rainfall and/or absorption of moisture from soil.
- 11.2** If manual hydration is necessary, water can be introduced by flooding the lined area or using a sprinkler system. Contact CETCO for specific procedures in these cases.

12 Shipping, Handling and Storage

- 12.1** All lot and roll numbers should be recorded and compared to the packing list. Each roll of GCL should also be visually inspected during unloading to determine if any packaging has been damaged. Damage, whether obvious or suspected, should be recorded and marked.
- 12.2** Major damage suspected to have occurred during transit should be reported immediately to the carrier and to CETCO. The nature of the damage should also be indicated on the bill of lading with the specific lot and roll numbers.
- 12.3** The party directly responsible for unloading the GCL should refer to this manual prior to shipment to ascertain the appropriateness of their unloading equipment and procedures. Unloading and on-site handling of the GCL should be supervised to ensure these goals are achieved. Roll dimensions and weights will vary with the dimensions of the product ordered.
- 12.4** Rolls should be stacked in a manner that prevents them from sliding or rolling from the stacks. This can be accomplished by frequent chocking of the bottom layer of rolls. Rolls should be stacked no higher than the height at which the spreader bar assembly can be safely handled by laborers (typically no higher than four). Rolls should never be stacked on end.
- 12.5** Rolls should be stored at the job site away from high-traffic areas but sufficiently close to the active work area to minimize handling. The designated storage area should be flat, dry and stable. Moisture protection of the GCL is provided by its packaging; however, an additional tarpaulin or plastic sheet is recommended.



NOTICE: This document is intended for use as a GENERAL GUIDELINE for the installation of CETCO's GCLs. The information and data contained herein are believed to be accurate and reliable. CETCO makes no warranty of any kind and accepts no responsibility for the results obtained through application of this information.

Appendix C3

GCL Laboratory Test Results



Precision Geosynthetic Laboratories

January 24, 2001

R001955

ISO 9002



Mr. Marty Cieslik
FOTH & VAN DYKE
406 Science Drive
Madison, WI 53711

Dear Mr. Cieslik:

RE: Modern Plating / 97M015

Thank you for consulting Precision Geosynthetic Laboratories for your material testing needs.

It should be noted that the test specimen and test sample used for this report was believed to be representative of the material produced under the designation herein stated. However, these results are indicative of only the specimens that were actually tested. The testing herein is based upon accepted industry practice as well as the test method listed. Precision Geosynthetic Laboratories neither accepts responsibility for nor makes claims to the final use and purpose of the material.

By accepting the data and results represented on this report, Client agrees to limit the liability of Precision Geosynthetic Laboratories from Client and all other parties for claims arising out of the use of this data to the cost for the respective test(s) represented in this report, and Client agrees to indemnify and hold harmless Precision Geosynthetic Laboratories from and against all liability in excess of the aforementioned limit.

The test data and all associated project information shall be held in confidence and disclosed to other parties only with the authorization of Client or Precision Geosynthetic Laboratories.

It is a company policy to keep the physical records of each job for 2 years since the receipt of the samples and keep the electronic file for 7 years. **Failed seam samples are kept for 7 years; good seam samples are disposed after 2 weeks and conformance samples are disposed after 1 month.** Should you need us to keep them longer, please advise us in writing.

If you have any questions or if we may be of further service, please do not hesitate to call at 800-522-4599.

Sincerely,

PRECISION GEOSYNTHETIC LABORATORIES

Edith Pintor
Quality Assurance

Cora B. Queja
Vice President

Enclosure: (Job No. 010055)

1160 North Gilbert Street, Anaheim, CA 92801, Tel # 714-520-9631, Fax # 714-520-9637



Precision Geosynthetic Laboratories

CLIENT: FOTH & VAN DYKE
PROJECT: Modern Plating / 97M015

ISO 9002



VERIFICATION OF MATERIAL PROPERTIES (PGL Job No. 010055)

MATERIAL DESCRIPTION: GCL- Final Cover

SAMPLED BY: FOTH & VAN DYKE

DATE RECEIVED: January 18, 2001

DATE REPORTED: January 24, 2001

SAMPLE IDENTIFICATIONS:

SAMPLE ID	PRECISION CONTROL NUMBER
Roll 2272	69050

TESTS REQUIRED:

TEST METHOD	DESCRIPTION
ASTM D1777	Thickness
ASTM D5993	Mass Per Unit Area
ASTM D4632	Grab Tensile
ASTM D4632, <i>Modified</i>	Peel Strength
ASTM D4643, <i>Microwave Method</i>	Moisture Content
ASTM D5084	Hydraulic Conductivity
ASTM D5887	Index Flux
ASTM D5890	Swell Index
ASTM D5891	Fluid Loss
ASTM D5321	Internal Shear Strength

TEST CONDITIONS: The sample was conditioned for a minimum one hour in the laboratory at $22 \pm 2^{\circ}\text{C}$ ($71.6 \pm 3.6^{\circ}\text{F}$) and at $60 \pm 10\%$ relative humidity prior to test.

TEST RESULTS:

The test results are summarized in Table 1 and 2. The units in which the data are reported are included on the table.

PRECISION GEOSYNTHETIC LABORATORIES



Edith Pintor
Quality Assurance

Cora B. Queja
Vice President

1160 North Gilbert Street, Anaheim, CA 92801, Tel # 714-520-9631, Fax # 714-520-9637

TABLE 1.
MATERIAL PROPERTIES
CLIENT: FOTH & VAN DYKE
PROJECT: Modern Plating / 97M015

Date Received: 1/18/01
 Date Final Reported: 1/24/01
 Client Sample ID: Roll 2272
 Material Description: GCL- Final Cover

QC'd By: 
 PGL Job No.: 010055
 PGL Control No.: 69050

		SPECIMENS										Avg.	Std. Dev.	Proj. Specs.
		1	2	3	4	5	6	7	8	9	10			
METHOD	DESCRIPTION													
ASTM D1777	Thickness (in)	0.339	0.340	0.350	0.341	0.338	0.341	0.338	0.340	0.338	0.339	0.340	0.004	0.25 min.
ASTM D5993	Mass per Unit Area (lbs/ ft. ²) (Bentonite Content)	0.93	0.98	0.94	0.96	0.94						0.95	0.02	0.75 min.
ASTM D4632	Grab Tensile													
	Tensile Strength (lbs)													
	MD	391	387	401	402	387	392	387	390	402	386	393	7	70 min.
	TD	437	420	411	405	412	396	402	440	412	400	413	15	
	Elongation at Peak (percent)													
	MD	98	96	98	99	96	98	96	98	97	90	97	2	
	TD	128	123	130	118	123	127	118	133	119	126	124	5	
ASTM D4643	Water (Moisture) Content (percent)	14.8	14.5	14.7						14.7	0.1	12 max.		
ASTM D5084	Hydraulic Conductivity (cm./ sec.) (Confining Stress = 30 psi)	3.2E-09										3.2E-09		5x10 ⁻⁹ max.
ASTM D5887	Index Flux (m. ³ / m. ² /sec.)	3.2E-09										3.2E-09		5x10 ⁻⁹ max.
ASTM D5890	Swell Index (mL/ 2 g.)	28.0										28.0	N/A	24 min.
ASTM D4632	Peel Strength (lbs)													
Modified	MD	45	44	49	49	41						46	3	15 min.
	TD	68	71	70	59	60						65	6	
ASTM D5891	Fluid Loss (mL)	7.4										7.4	N/A	18 max.
													ISO	9002



Precision Geosynthetic Laboratories

MD - MACHINE DIRECTION
 TD - TRANSVERSE DIRECTION



R001957

44

CLIENT: FOTH & VAN DYKE
 PROJECT: Modern Plating/ 97M015

INTERFACE SHEAR TEST RESULT (ASTM D6243)
 (PGL Job No. 010055)

QC'd by: 
 January 26, 2001

TEST CONFIGURATION #1

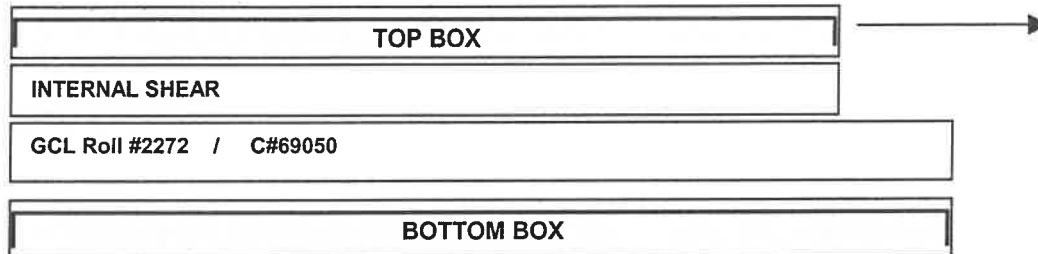

TEST CONDITIONS:

SAMPLE PREPARATION:

1. Specimens were cut to 20" x 20"

HYDRATION:

1. GCL specimens were hydrated for 24 hours at normal load.

CONSOLIDATION:

1. Each set of specimen was consolidated under drained condition for 24 hours at normal load before shearing.

SHEAR TEST:

1. Shear test was conducted at 0.04 in/ min.
2. Sheared at minimum 3.2 inch horizontal displacement.
3. The test specimens were sheared in drained condition.
4. Initial moisture content of the GCL was 14.63%, and the final moisture content was 75.60%, 85.36 %, and 91.90% for 36psf, 72psf and 144psf respectively.
5. Tests were performed in general accordance with ASTM D6243 using Brainard-Kilman LG-112 Direct Shear machine with effective area of 12 in x 12 in.

TEST RESULTS:

NORMAL STRESS		PEAK STRENGTH		3.2" DISPLACEMENT STRENGTH	
(psi)	(psf)	SHEAR STRESS (psf)	PEAK SECANT ANGLE	SHEAR STRESS (psf)	3.2" DISPLACEMENT SECANT ANGLE
0.25	36	1787	89	942	88
0.50	72	1821	88	1020	86
1.0	144	1843	86	1001	82
COHESION (psf):		1776		952	
FRICTION ANGLE (degrees):		26		23	
COEFFICIENT OF FRICTION:		0.49		0.43	

NOTE: The friction angles and cohesion results given here are based on mathematically determined best fit line.

OBSERVATIONS:

Failure occurred along the interface. See Figure #1 and #2



Precision Geosynthetic Laboratories

ISO 9002



Figure #1
Shear Stress/ Displacement Curve
PGL Job No. 010055_1

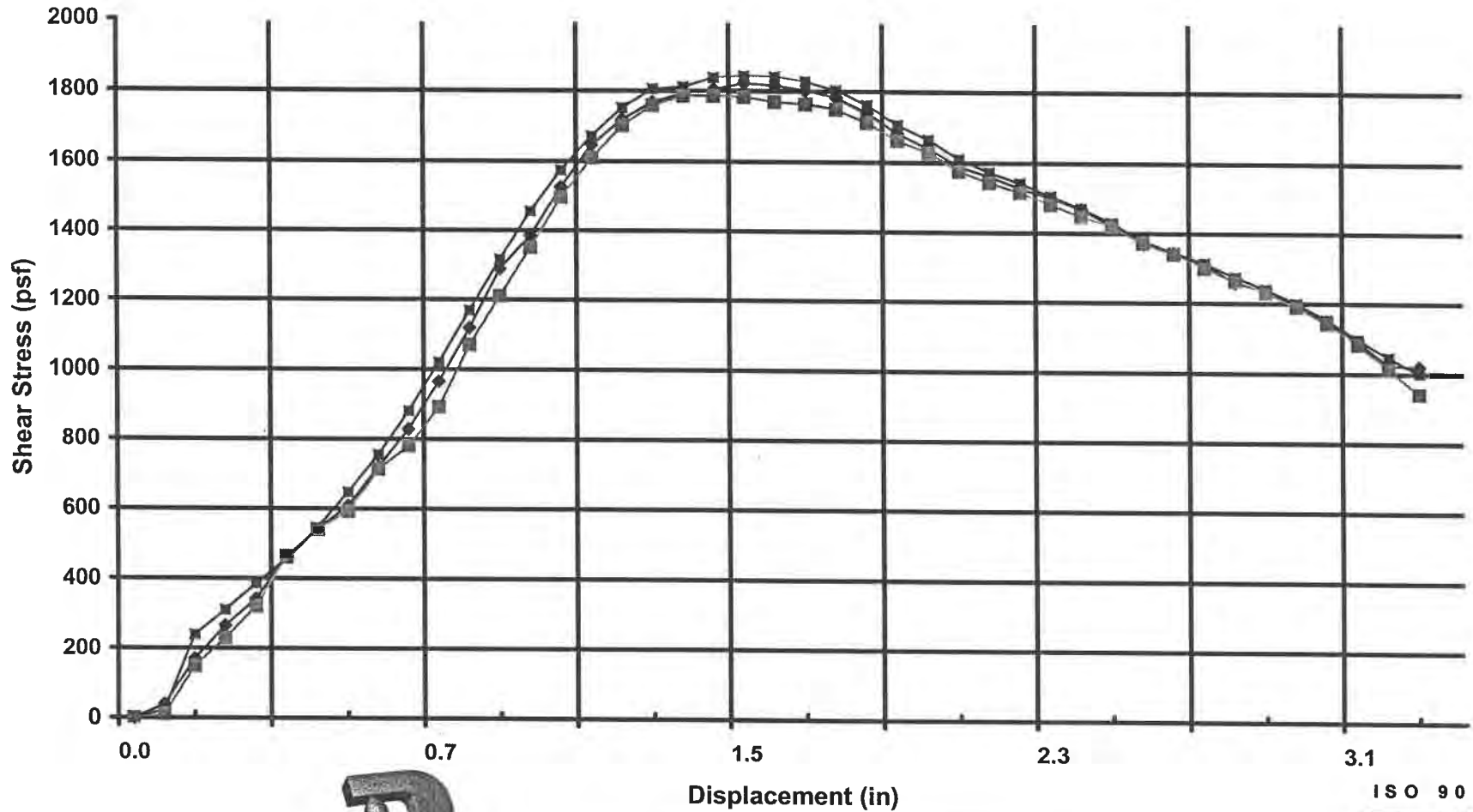

Precision Geosynthetic Laboratories

—■— 144PSF —◆— 72PSF —▲— 36PSF

ISO 9002



Figure #2
 Normal Stress/ Interface Stress
 PGL Job No. 010055_1

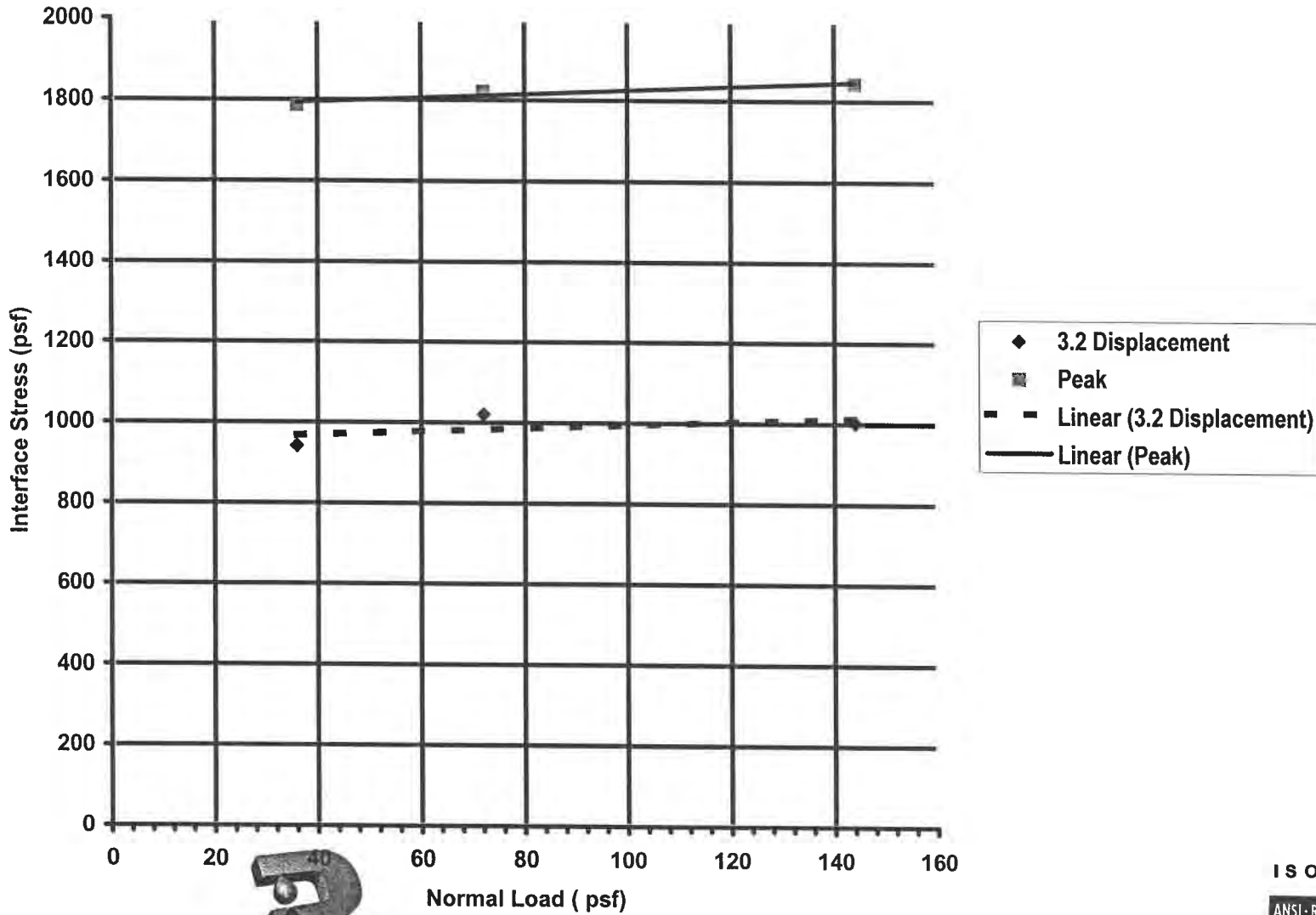

47



Precision Geosynthetic Laboratories



R001960

CONFORMANCE TEST CHAIN OF CUSTODY FORM 001961

Precision Geosynthetic Laboratories
 1150 North Gilbert Street
 Anaheim, CA 92801
 (800-522-4599)

PROJECT NAME / PROJECT NUMBER: MODERN PLATING / 97MOIS
 PROJECT LOCATION: FREERBAY, IL

GEOMEMBRANE TESTING

SAMPLE ID	Thickness ASTM D5199 or D5694	Density ASTM D1505 or D792	Carbon Black Content ASTM D1600	Carbon Dispersion D3015/ D5596	Tensile ASTM D638 GM13 / NSF54	Tear Resistance ASTM D1004 (Die C)	Puncture D4803 /101CM2006	Melt Flow Index ASTM D1238, cond E	Dimensional Stability ASTM D1204	Low Temp. Brittleness D746/ D1790	NCTL ASTM D5397 Hours	Other
1000												

NONWOVEN OR WOVEN GEOTEXTILE TESTING

SAMPLE ID	Thickness ASTM D5199 or D1777	Mass Per Area ASTM D5261 or D3776	Grab Tensile ASTM D4632	Trapezoid Tear ASTM D4533	Puncture Resistance ASTM D4803	Mullen Burst ASTM D3776	Permittivity ASTM D4491	AOS ASTM D4751	Wide Width Tensile ASTM D4596	UV (hrs) ASTM D4359	Other	Other

GEOCOMPOSITE / GEONET / GEORIGID TESTING

SAMPLE ID	Thickness ASTM D5169 or D1777	Density ASTM D1505 or D792	Carbon Black Content ASTM D1603	Mass Per Area ASTM D5261 or D3776	Melt Flow Index ASTM D1238, cond E	Poel ASTM D413, F904 or GRI-GC7	Transmissivity* ASTM D4716	Compression ASTM D1621	Tensile Strength ASTM D1082 or D5035	Wide Width Tensile ASTM D4596	Rb Tensile Strength GRI-GG1	Junction Strength GRI-GG2

* Transmissivity Test Parameters: Normal Load _____ Gradient _____ Sealing Time _____ Boundary Condition _____

GCL TESTING

SAMPLE ID	Thickness ASTM D5199	Mass Per Area ASTM D5693	Grab Tensile ASTM D4632	Poel Strength ASTM D8496	Moisture Content ASTM D4643 or D2218	Hydraulic Conductivity ASTM D5084	Index Flux ASTM D5687	Swell Index ASTM D5890	Fluid Loss ASTM D5691	Internal Shear Strength ASTM D6249	Other	Other
<u>GCL-FINAL COVER</u>	<input checked="" type="checkbox"/>	<input checked="" type="checkbox"/>	<input checked="" type="checkbox"/>	<input checked="" type="checkbox"/>	<input checked="" type="checkbox"/>	<input checked="" type="checkbox"/>	<input checked="" type="checkbox"/>	<input checked="" type="checkbox"/>	<input checked="" type="checkbox"/>	<input checked="" type="checkbox"/>		

SEND REPORT TO:

Name: MARTY CIESLIK

Company: FOTH & VAN DYKE

Address: 406 SCIENCE DR. STE. 400, MUNDYVILLE

Phone: (608) 238-4761

Fax: (608) 238-4633

E-mail: mcieslik@fth.com

FIELD CONTACT:

Name: BEJAN STANUL

Phone: (608) 576-1635

Fax: (608) 238-4761

E-mail: bstanul@fth.com

Received by: NAME

Date: 1/19/11

SHIPPED VIA:

Name: BEJAN STANUL

Date/Time: 1/19/11

Received by: NAME

Date/Time: 1/19/11

Received by: NAME

Date/Time: 1/19/11

- FedEx
- UPS
- Airborne
- DHL
- US Mail
- Other



Precision Geosynthetic Laboratories

January 25, 2001

Mr. Marty Cieslik
FOTH & VAN DYKE
406 Science Drive
Madison, WI 53711

Dear Mr. Cieslik:

RE: Modern Plating / 97M015

Thank you for consulting Precision Geosynthetic Laboratories for your material testing needs.

It should be noted that the test specimen and test sample used for this report was believed to be representative of the material produced under the designation herein stated. However, these results are indicative of only the specimens that were actually tested. The testing herein is based upon accepted industry practice as well as the test method listed. Precision Geosynthetic Laboratories neither accepts responsibility for nor makes claims to the final use and purpose of the material.

By accepting the data and results represented on this report, Client agrees to limit the liability of Precision Geosynthetic Laboratories from Client and all other parties for claims arising out of the use of this data to the cost for the respective test(s) represented in this report, and Client agrees to indemnify and hold harmless Precision Geosynthetic Laboratories from and against all liability in excess of the aforementioned limit.

The test data and all associated project information shall be held in confidence and disclosed to other parties only with the authorization of Client or Precision Geosynthetic Laboratories.

It is a company policy to keep the physical records of each job for 2 years since the receipt of the samples and keep the electronic file for 7 years. **Failed seam samples are kept for 7 years; good seam samples are disposed after 2 weeks and conformance samples are disposed after 1 month.** Should you need us to keep them longer, please advise us in writing.

If you have any questions or if we may be of further service, please do not hesitate to call at 800-522-4599.

Sincerely,

PRECISION GEOSYNTHETIC LABORATORIES

Edith Pintor
Quality Assurance

Cora B. Queja
Vice President

Enclosure: (Job No. 010056)

1160 North Gilbert Street, Anaheim, CA 92801, Tel # 714-520-9631, Fax # 714-520-9637



Precision Geosynthetic Laboratories

CLIENT: FOTH & VAN DYKE
 PROJECT: Modern Plating / 97M015

ISO 9002



VERIFICATION OF MATERIAL PROPERTIES
 (PGL Job No. 010056)

MATERIAL DESCRIPTION: GCL

SAMPLED BY: FOTH & VAN DYKE OF MADISON

DATE RECEIVED: January 18, 2001

DATE REPORTED: January 25, 2001

SAMPLE IDENTIFICATIONS:

SAMPLE ID	PRECISION CONTROL NUMBER
GCL-1	69051
GCL-2	69052
GCL-3 Roll 2272	69053
GCL-4 Roll 2739	69054
GCL-5 Roll 2737	69055
GCL-6 Roll 2736	69056
GCL-7 Roll 2743	69057
GCL-8 Roll 2744	69058
GCL-9 Roll 2742	69059
GCL-10 Roll 2738	69060
GCL-11 Roll 2746	69061
GCL-12 Roll 2747	69062

TESTS REQUIRED:

TEST METHOD	DESCRIPTION
ASTM D1777	Thickness
ASTM D5993	Mass Per Unit Area

TEST CONDITIONS: The samples were conditioned for a minimum one hour in the laboratory at $22 \pm 2^{\circ}\text{C}$ ($71.6 \pm 3.6^{\circ}\text{F}$) and at $60 \pm 10\%$ relative humidity prior to test.

TEST RESULTS:

The test results are summarized in Tables 1 through 12. The units in which the data are reported are included on the tables

PRECISION GEOSYNTHETIC LABORATORIES



Edith Pintor
 Quality Assurance

[Signature]
 Cora B. Queja
 Vice President

1160 North Gilbert Street, Anaheim, CA 92801, Tel # 714-520-9631, Fax # 714-520-9637

TABLE 1.
MATERIAL PROPERTIES
CLIENT: FOTH & VAN DYKE
PROJECT: Modern Plating / 97M015

Date Received: 1/18/01
 Date Reported: 1/25/01
 Client Sample ID: GCL-1
 Material Description: GCL

QC'd By: 
 PGL Job No.: 010056
 PGL Control No.: 69051

METHOD DESCRIPTION	SPECIMENS										Avg.	Std. Dev.	Proj. Specs.
	1	2	3	4	5	6	7	8	9	10			
ASTM D1777 Thickness (in)	0.338	0.341	0.339	0.344	0.346	0.339	0.341	0.338	0.340	0.344	0.341	0.003	0.25 min.
ASTM D5993 Mass per Unit Area of the Clay (lbs/ ft2)	0.97	0.95									0.96	0.017	0.75 min.

51



Precision Geosynthetic Laboratories

ISO 9002



R001964

TABLE 2.
MATERIAL PROPERTIES
CLIENT: FOTH & VAN DYKE
PROJECT: Modern Plating / 97M015

Date Received: 1/18/01
 Date Reported: 1/25/01
 Client Sample ID: GCL-2
 Material Description: GCL

QC'd By: 
 PGL Job No. : 010056
 PGL Control No. : 69052

		SPECIMENS													
		1	2	3	4	5	6	7	8	9	10	Avg.	Std. Dev.	Proj. Specs.	
METHOD	DESCRIPTION														
ASTM D1777	Thickness (in)	0.328	0.336	0.326	0.340	0.329	0.340	0.328	0.334	0.342	0.329	0.333	0.006	0.25 min.	
ASTM D5993	Mass per Unit Area of the Clay (lbs/ ft ²)	0.88	0.87										0.88	0.004	0.75 min.

52



Precision Geosynthetic Laboratories



R001965

TABLE 3.
MATERIAL PROPERTIES
CLIENT: FOTH & VAN DYKE
PROJECT: Modern Plating / 97M015

Date Received: 1/18/01
 Date Reported: 1/25/01
 Client Sample ID: GCL-3 Roll 2272
 Material Description: GCL

QC'd By: 
 PGL Job No. : 010056
 PGL Control No. : 69053

		SPECIMENS												
		1	2	3	4	5	6	7	8	9	10	Avg.	Std. Dev.	Proj. Specs.
METHOD	DESCRIPTION													
ASTM D1777	Thickness (in)	0.335	0.328	0.334	0.336	0.328	0.335	0.338	0.330	0.328	0.328	0.332	0.004	0.25 min.
ASTM D5993	Mass per Unit Area of the Clay (lbs/ft ²)	0.97	0.94									0.95	0.018	0.75 min.

53



Precision Geosynthetic Laboratories

ISO 9002



R001966

TABLE 4.
MATERIAL PROPERTIES
CLIENT: FOTH & VAN DYKE
PROJECT: Modern Plating / 97M015

Date Received: 1/18/01
 Date Reported: 1/25/01
 Client Sample ID: GCL-4 Roll 2739
 Material Description: GCL

QC'd By: 
 PGL Job No. : 010056
 PGL Control No. : 69054

		SPECIMENS												
		1	2	3	4	5	6	7	8	9	10	Avg.	Std. Dev.	Proj. Specs.
METHOD	DESCRIPTION													
ASTM D1777	Thickness (in)	0.351	0.355	0.360	0.353	0.366	0.362	0.365	0.353	0.355	0.357	0.358	0.005	0.25 min.
ASTM D5993	Mass per Unit Area of the Clay (lbs/ ft ²)	0.90	0.89									0.90	0.007	0.75 min.

54



Precision Geosynthetic Laboratories



R001967

TABLE 5.
MATERIAL PROPERTIES
CLIENT: FOTH & VAN DYKE
PROJECT: Modern Plating / 97M015

Date Received: 1/18/01
 Date Reported: 1/25/01
 Client Sample ID: GCL-5 Roll 2737
 Material Description: GCL

QC'd By: 
 PGL Job No. : 010056
 PGL Control No. : 69055

SPECIMENS

METHOD DESCRIPTION	SPECIMENS										Avg.	Std. Dev.	Proj. Specs.
	1	2	3	4	5	6	7	8	9	10			
ASTM D1777 Thickness (in)	0.366	0.364	0.359	0.365	0.367	0.366	0.369	0.365	0.368	0.362	0.365	0.003	0.25 min.
ASTM D5993 Mass per Unit Area of the Clay (lbs/ ft ²)	0.97	0.97									0.97	0.002	0.75 min



Precision Geosynthetic Laboratories

ISO 9002



R001968

TABLE 6.
MATERIAL PROPERTIES
CLIENT: FOTH & VAN DYKE
PROJECT: Modern Plating / 97M015

Date Received: 1/18/01
 Date Reported: 1/25/01
 Client Sample ID: GCL-6 Roll 2736
 Material Description: GCL

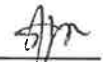
QC'd By: 
 PGL Job No.: 010056
 PGL Control No.: 69056

METHOD DESCRIPTION	SPECIMENS										Avg.	Std. Dev.	Proj. Specs.
	1	2	3	4	5	6	7	8	9	10			
ASTM D1777 Thickness (in)	0.372	0.367	0.360	0.370	0.370	0.358	0.371	0.370	0.370	0.362	0.367	0.005	0.25 min.
ASTM D5993 Mass per Unit Area of the Clay (lbs/ ft2)	0.91	0.96									0.93	0.037	0.75 min.

56



Precision Geosynthetic Laboratories

ISO 9002



R001969

TABLE 7.
MATERIAL PROPERTIES
CLIENT: FOTH & VAN DYKE
PROJECT: Modern Plating / 97M015

Date Received: 1/18/01
 Date Reported: 1/25/01
 Client Sample ID: GCL-7 Roll 2743
 Material Description: GCL

QC'd By: 
 PGL Job No. : 010056
 PGL Control No. : 69057

		SPECIMENS										Avg.	Std. Dev.	Proj. Specs.
METHOD	DESCRIPTION	1	2	3	4	5	6	7	8	9	10			
ASTM D1777	Thickness (in)	0.339	0.348	0.351	0.349	0.336	0.349	0.351	0.341	0.347	0.348	0.346	0.005	0.25 min.
ASTM D5993	Mass per Unit Area of the Clay (lbs/ ft ²)	0.89	0.91									0.90	0.011	0.75 min.



Precision Geosynthetic Laboratories

ISO 9002



R001970

TABLE 8.
MATERIAL PROPERTIES
CLIENT: FOTH & VAN DYKE
PROJECT: Modern Plating / 97M015

Date Received: 1/18/01
 Date Reported: 1/25/01
 Client Sample ID: GCL-8 Roll 2744
 Material Description: GCL

QC'd By: 
 PGL Job No. : 010056
 PGL Control No. : 69058

METHOD DESCRIPTION	SPECIMENS										Avg.	Std. Dev.	Proj. Specs.
	1	2	3	4	5	6	7	8	9	10			
ASTM D1777 Thickness (in)	0.358	0.356	0.361	0.351	0.358	0.350	0.347	0.358	0.361	0.360	0.356	0.005	0.25 min.
ASTM D5993 Mass per Unit Area of the Clay (lbs/ft ²)	1.01	0.75									0.88	0.183	0.75 min.

58



Precision Geosynthetic Laboratories

ISO 9002



R001971

TABLE 9.
MATERIAL PROPERTIES
CLIENT: FOTH & VAN DYKE
PROJECT: Modern Plating / 97M015

Date Received: 1/18/01
 Date Reported: 1/25/01
 Client Sample ID: GCL-9 Roll 2742
 Material Description: GCL

QC'd By: 
 PGL Job No. : 010056
 PGL Control No. : 69059

		SPECIMENS												Proj. Specs.		
		1	2	3	4	5	6	7	8	9	10	Avg.	Std. Dev.			
METHOD	DESCRIPTION															
ASTM D1777	Thickness (in)	0.356	0.349	0.359	0.347	0.346	0.350	0.353	0.349	0.357	0.349	0.351	0.005	0.25 min.		
ASTM D5993	Mass per Unit Area of the Clay (lbs/ft ²)	0.92	0.92											0.92	0.004	0.75 min.

59



Precision Geosynthetic Laboratories



R001972

TABLE 10.
MATERIAL PROPERTIES
CLIENT: FOTH & VAN DYKE
PROJECT: Modern Plating / 97M015

Date Received: 1/18/01
 Date Reported: 1/25/01
 Client Sample ID: GCL-10 Roll 2738
 Material Description: GCL

QC'd By: 
 PGL Job No. : 010056
 PGL Control No. : 69060

		SPECIMENS										Avg.	Std. Dev.	Proj. Specs.	
		1	2	3	4	5	6	7	8	9	10				
METHOD	DESCRIPTION														
ASTM D1777	Thickness (in)	0.366	0.349	0.370	0.358	0.364	0.357	0.365	0.361	0.368	0.370	0.363	0.007	0.25 min.	
ASTM D5993	Mass per Unit Area of the Clay (lbs/ ft ²)	0.95	0.94										0.94	0.006	0.75 min

60



Precision Geosynthetic Laboratories



R001973

TABLE 11.
MATERIAL PROPERTIES
CLIENT: FOTH & VAN DYKE
PROJECT: Modern Plating / 97M015

Date Received: 1/18/01
 Date Reported: 1/25/01
 Client Sample ID: GCL-11 Roll 2746
 Material Description: GCL

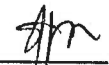
QC'd By: 
 PGL Job No.: 010056
 PGL Control No.: 69061

METHOD DESCRIPTION	SPECIMENS										Avg.	Std. Dev.	Proj. Specs.
	1	2	3	4	5	6	7	8	9	10			
ASTM D1777 Thickness (in)	0.341	0.365	0.338	0.361	0.340	0.339	0.365	0.355	0.349	0.339	0.349	0.011	0.25 min.
ASTM D5993 Mass per Unit Area of the Clay (lbs/ ft2)	0.87	0.87									0.87	0.003	0.75 min.

61



Precision Geosynthetic Laboratories

ISO 9002



R001974

TABLE 12.
MATERIAL PROPERTIES
CLIENT: FOTH & VAN DYKE
PROJECT: Modern Plating / 97M015

Date Received: 1/18/01
 Date Reported: 1/25/01
 Client Sample ID: GCL-12 Roll 2747
 Material Description: GCL

QC'd By: 
 PGL Job No. : 010056
 PGL Control No. : 69062

		SPECIMENS												
		1	2	3	4	5	6	7	8	9	10	Avg.	Std. Dev.	Proj. Specs.
METHOD	DESCRIPTION													
ASTM D1777	Thickness (in)	0.350	0.347	0.366	0.349	0.370	0.359	0.345	0.368	0.369	0.358	0.358	0.010	0.25 min.
ASTM D5993	Mass per Unit Area of the Clay (lbs/ ft ²)	0.87	0.80									0.84	0.049	0.75 min.

62



Precision Geosynthetic Laboratories



R001975

CONFORMANCE TEST CHAIN OF CUSTODY FORM

Page 1 of 12

001976

Precision Geosynthetic Laboratories
1150 North Gilbert Street
Anaheim, CA 92801
(800-522-4599)

PROJECT NAME / PROJECT NUMBER: MODEAU PARTING 192MOLS
PROJECT LOCATION: FREIBERG, IL

GEOMEMBRANE TESTING

SAMPLE ID	Thickness ASTM D5199 or D5594	Density ASTM D1505 or D792	Carbon Black Content ASTM D1603	Carbon Dispersion D3015/ D5596	Tensile ASTM D638 GM13 / NSF54	Tear Resistance ASTM D1004 (Die C)	Puncture D4833 /101CM2005	Melt Flow Index ASTM D1238, cond E	Dimensional Stability ASTM D1204	Low Temp. Brittleness D746/ D1790	NCTL ASTM D5397 Hours	Other

NONWOVEN OR WOVEN GEOTEXTILE TESTING

SAMPLE ID	Thickness ASTM D5199 or D1777	Mass Per Area ASTM D5261 or D3776	Grab Tensile ASTM D4632	Trapezoid Tear ASTM D4533	Puncture Resistance ASTM D4833	Mullen Burst ASTM D3778	Permeability ASTM D4491	AOS ASTM D4751	Wide Width Tensile ASTM D4596	UV (hrs) ASTM D4355	Other	Other

GEOCOMPOSITE / GEONET / GEORIG TESTING

SAMPLE ID	Thickness ASTM D5169 or D1777	Density ASTM D1505 or D792	Carbon Black Content ASTM D1603	Mass Per Area ASTM D5261 or D3776	Melt Flow Index ASTM D1238, cond E	Pool ASTM D413, F904 or GRI-GC7	Transmissivity ASTM D4716	Compression ASTM D1621	Tensile Strength ASTM D1082 or D5035	Wide Width Tensile ASTM D4595	Rb Tensile Strength GRI-GG1	Junction Strength GRI-GG2

• Transmissivity Test Parameters: Normal Load Gradient Sealing Time Boundary Condition

GCL TESTING

SAMPLE ID	Thickness ASTM D5199	Mass Per Area ASTM D5693	Grab Tensile ASTM D4632	Pool Strength ASTM D8496	Moisture Content ASTM D4643 or D2218	Hydraulic Conductivity ASTM D5084	Index Flux ASTM D5687	Swell Index ASTM D5890	Fluid Loss ASTM D5691	Internal Shear Strength ASTM D6243	Other	Other
GCL-1	✓	✓	✓									
GCL-2	✓	✓										
GCL-3	✓	✓										
(Roll # 2273)												

SEND REPORT TO:

Name: MARKY CIESLIK

Company: FOTH & VAN DYKE

Address: 406 SCIENCE DR, STE 400, WADSWORTH, ILL

Phone: (608) 238-4761

Fax: (608) 238-4633

e-mail: lostawa@fth.com

FIELD CONTACT:

Name: BRIAN STANUL

Phone: (608) 576-1635

Fax: (608) 238-4761

e-mail: (608) 238-4633

Reviewed by: BRIAN STANUL

Date: 1/17/01

Received by: ARJA

Name: ARJA

Date: 1/18/01

PGL

- Shipped Via:
- FedEx
 - UPS
 - Airborne
 - DHL
 - US Mail
 - Other

CONFORMANCE TEST CHAIN OF CUSTODY FORM

Precision Geosynthetic Laboratories
 1160 North Gilbert Street
 Anaheim, CA 92801
 (800-522-4599)

PROJECT NAME / PROJECT NUMBER:
 PROJECT LOCATION:

GEOMEMBRANE TESTING

SAMPLE ID	Thickness ASTM D5199 or D5594	Density ASTM D1505 or D792	Carbon Black Content ASTM D1603	Carbon Dispersion D3015/ D5596	Tensile ASTM D638 GRI3 / NSF54	Tear Resistance ASTM D1004 (Die C)	Puncture D4833 /101CM2005	Melt Flow Index ASTM D1238, cond E	Dimensional Stability ASTM D1204	Low Temp. Britleness D746/ D1790	NCTL ASTM D5397 Hours Other ASTM

NONWOVEN OR WOVEN GEOTEXTILE TESTING

SAMPLE ID	Thickness ASTM D5109 or D1777	Mass Per Area ASTM D5261 or D3776	Grab Tensile ASTM D4632	Trapezoid Tear ASTM D4533	Puncture Resistance ASTM D4833	Mullen Burst ASTM D3778	Perm.ivity ASTM D4491	AOS ASTM D4751	Wide Width Tensile ASTM D4596	UV (hrs) ASTM D4359	Other ASTM	Other ASTM

GEOCOMPOSITE / GEONET / GEOGRID TESTING

SAMPLE ID	Thickness ASTM D5169 or D1777	Density ASTM D1505 or D792	Carbon Black Content ASTM D1603	Mass Per Area ASTM D5261 or D3776	Melt Flow Index ASTM D1238, cond E	Pool ASTM D413, F904 or GRI-GC7	Transmissivity ASTM D4716	Compression ASTM D1621	Tensile Strength ASTM D1882 or D5035	Wide Width Tensile ASTM D4596	Rb Tensile Strength GRI-GG1	Junction Strength GRI-GG2

• Transmissivity Test Parameters: Normal Load _____ Gradient _____ Sealing Time _____ Boundary Condition _____

GCL TESTING

SAMPLE ID	Thickness ASTM D5199	Mass Per Area ASTM D5693	Grab Tensile ASTM D4632	Pool Strength ASTM D8496	Moisture Content ASTM D4643 or D2216	Hydraulic Conductivity ASTM D5084	Index Fax ASTM D5887	Swell Index ASTM D5890	Fluid Loss ASTM D5691	Internal Shear Strength ASTM D6249	Other ASTM	Other ASTM
GCL-4 (Roll # 2739)	✓	✓										
GCL-5 (Roll # 2737)	✓	✓										

SEND REPORT TO: SAWE

FIELD CONTACT: SAWE

Company Name: _____ Address: _____ Phone: _____ Fax: _____ e-mail: _____

Page: _____

Received by: MARLA

Date/Time: 1/18/01

Shipped Via: UPS Airborne DHL US Mail Other

64

CONFORMANCE TEST CHAIN OF CUSTODY FORM

Precision Geosynthetic Laboratories
 1150 North Gilbert Street
 Anaheim, CA 92801
 (800-522-4599)

PROJECT NAME / PROJECT NUMBER:
 PROJECT LOCATION:

GEOMEMBRANE TESTING

SAMPLE ID	Thickness ASTM D5199 or D5594	Density ASTM D1505 or D792	Carbon Black Content ASTM D1603	Carbon Dispersion D3015/ D5596	Tensile ASTM D638 GM13 / NSF54	Tear Resistance ASTM D1004 (Die C)	Puncture D4833 /101CM2006	Melt Flow Index ASTM D1238, cond E	Dimensional Stability ASTM D1204	Low Temp. Brittleness D746/ D1790	NCTL ASTM D5397 Hours	Other

NONWOVEN OR WOVEN GEOTEXTILE TESTING

SAMPLE ID	Thickness ASTM D5199 or D1777	Mass Per Area ASTM D5261 or D3776	Grab Tensile ASTM D4632	Trapezoid Tear ASTM D4530	Puncture Resistance ASTM D4833	Mullen Burst ASTM D3778	Permeability ASTM D4491	AOS ASTM D4751	Wide Width Tensile ASTM D4595	UV (hrs) ASTM D4355	Other	Other

GEOCOMPOSITE / GEONET / GEORID TESTING

SAMPLE ID	Thickness ASTM D5199 or D1777	Density ASTM D1505 or D792	Carbon Black Content ASTM D1603	Mass Per Area ASTM D5261 or D3776	Melt Flow Index ASTM D1238, cond E	Pool ASTM D413, F904 or GRI-GC7	Transmissivity * ASTM D4716	Compression ASTM D1621	Tensile Strength ASTM D1682 or D5035	Wide Width Tensile ASTM D4595	Rd Tensile Strength GRI-GG1	Junction Strength GRI-GG2

* Transmissivity Test Parameters: Normal Load: _____ Gradient: _____ Satting Time: _____ Boundary Condition: _____

GCL TESTING

SAMPLE ID	Thickness ASTM D5199	Mass Per Area ASTM D5093	Grab Tensile ASTM D4632	Pool Strength ASTM D8496	Moisture Content ASTM D4643 or D2218	Hydraulic Conductivity ASTM D5084	Index Flux ASTM D5687	Swell Index ASTM D5890	Fluid Loss ASTM D5891	Internal Shear Strength ASTM D6243	Other	Other
GCL-6 (Roll # 2736)	✓	✓										
GCL-7 (Roll # 2743)	✓	✓										

SEND REPORT TO: Name: _____ Company: _____ Address: _____ Phone: _____ Fax: _____ e-mail: _____

FIELD CONTACT: Name: _____ Pager: _____ Mobile: _____ Phone: _____ Fax: _____ e-mail: _____

Received by: Name: _____ Date/Time: _____

Shipped Via: Fedex UPS Airborne DHL US Mail Other

65

Date: 1/18/07

CONFORMANCE TEST CHAIN OF CUSTODY FORM 1979

Precision Geosynthetic Laboratories
 1150 North Gilbert Street
 Anaheim, CA 92801

(800-522-4599)

PROJECT NAME / PROJECT NUMBER:

PROJECT LOCATION:

GEOMEMBRANE TESTING

SAMPLE ID	Thickness ASTM D5199 or D5694	Density ASTM D1505 or D792	Carbon Black Content ASTM D1600	Carbon Dispersion D3015/ D5596	Tensile ASTM D638 GRA3 / NSF54	Tear Resistance ASTM D1004 (Dia C)	Puncture D4833 /101CM2006	Melt Flow Index ASTM D1238, cond E	Dimensional Stability ASTM D1204	Low Temp. Brittleness D746/ D1790	NOTL ASTM D5397 Hours	Other

NONWOVEN OR WOVEN GEOTEXTILE TESTING

SAMPLE ID	Thickness ASTM D5199 or D5694	Mass Per Area ASTM D5261 or D3776	Grab Tensile ASTM D4632	Trapezoid Tear ASTM D4533	Puncture Resistance ASTM D4833	Mullen Burst ASTM D3778	Perm.ivity ASTM D4491	AOS ASTM D4751	Wide Width Tensile ASTM D4596	UV (hrs) ASTM D4359	Other	Oil or ASTM

GEOCOMPOSITE / GEONET / GEOGRID TESTING

SAMPLE ID	Thickness ASTM D5169 or D1777	Density ASTM D1505 or D792	Carbon Black Content ASTM D1600	Mass Per Area ASTM D5261 or D3776	Melt Flow Index ASTM D1238, cond E	Pool ASTM D413, F904 or GRI-GC7	Transmissivity* ASTM D4716	Compression ASTM D1621	Tensile Strength ASTM D1002 or D5035	Wide Width Tensile ASTM D4596	Rb Tensile Strength GRI-GG1	Junction Strength GRI-GG2

* Transmissivity Test Parameters: Normal Load: _____

Gradient: _____

Sealing Time: _____

Boundary Condition: _____

GCL TESTING

SAMPLE ID	Thickness ASTM D5199	Mass Per Area ASTM D5693	Grab Tensile ASTM D4632	Pool Strength ASTM D8496	Moisture Content ASTM D4643 or D2216	Hydraulic Conductivity ASTM D5084	Index Flux ASTM D5687	Swell Index ASTM D5890	Fluid Loss ASTM D5691	Internal Shear Strength ASTM D6243	Other	Oil or ASTM
GCL-8 (Rd1 # 2744)	✓	✓										
GCL-9 (Rd1 # 2742)	✓	✓										

SEND REPORT TO:

FIELD CONTACT

Name: _____
 Company: _____
 Address: _____
 Phone: _____
 Fax: _____
 E-mail: _____

Name: _____
 Project: _____
 Vessel: _____
 Phone: _____
 Fax: _____
 E-mail: _____

Released by: _____
 Name: _____
 Date/Time: _____

Received by: _____
 Name: W. A. R. A.
 Date/Time: 11/8/01

Shipped via:
 Fedex
 UPS
 Airborne
 OHL
 OJS Mail
 Other

CONFORMANCE TEST CHAIN OF CUSTODY FORM 1980

PROJECT NAME / PROJECT NUMBER _____

PROJECT LOCATION: _____

GEOMEMBRANE TESTING

SAMPLE ID	Thickness ASTM D5109 or D5634	Density ASTM D1505 or D792	Carbon Black Content ASTM D1600	Carbon Dispersion D3015/ D5506	Tensile ASTM D638 GM13 / NSF54	Tear Resistance ASTM D1004 (Dia C)	Puncture D4833 / D101CM2005	Melt Flow Index ASTM D1238, cond E	Dimensional Stability ASTM D1204	Low Temp. Brittleness D746/ D1790	ACIL ASTM D6397 Hours _____	Other ASTM _____

NONWOVEN OR WOVEN GEOTEXTILE TESTING

SAMPLE ID	Thickness ASTM D5109 or D1777	Mass Per Area ASTM D5261 or D3776	Grab Tensile ASTM D4632	Trapezoid Tear ASTM D4533	Puncture Resistance ASTM D4833	Mullen Burst ASTM D3778	Permittivity ASTM D4491	AOS ASTM D4751	Wide Width Tensile ASTM D4586	UV (hrs) _____ ASTM D4358	Other ASTM _____	Other ASTM _____

GEOCOMPOSITE / GEOTEXT / GEOGRID TESTING

SAMPLE ID	Thickness ASTM D5109 or D1777	Density ASTM D1505 or D792	Carbon Black Content ASTM D1600	Mass Per Area ASTM D5261 or D3776	Melt Flow Index ASTM D1238, cond E	Poc ASTM D113, F904 or GRI-GC7	Transmissivity ASTM D4716	Compression ASTM D1621	Tensile Strength ASTM D1082 or D5035	Wide Width Tensile ASTM D4586	Rb Tensile Strength GRI-GG1	Junction Strength GRI-GG2

• Transmissivity Test Parameters: Normal Load _____ Section _____ Sealing Time _____ Boundary Condition _____

GCL TESTING

SAMPLE ID	Thickness ASTM D5109	Mass Per Area ASTM D5093	Grab Tensile ASTM D4632	Pool Strength ASTM D8496	Moisture Content ASTM D4643 or D2716	Hydraulic Conductivity ASTM D5084	Index Fair ASTM D5687	Swell Index ASTM D5890	Fluid Loss ASTM D4691	Internal Shear Strength ASTM D6243	Other ASTM _____	Other ASTM _____
GCL-10	✓	✓										
(Roll # 2738)												
GCL-11	✓	✓										
(Roll # 2746)												

SEND REPORT TO:

FIELD CONTACT

Requested by:

Shipped Via:

Name _____ Company _____ Address _____ Phone _____ Fax _____
 Name _____ Page _____
 Name _____
 Name _____
 Date Time _____
 Received by: MASSIA
 Name _____
 Date _____ 1/18/01
 GCL _____
 Fedex UPS Airborne Other
 Mail Other



Precision Geosynthetic Laboratories

January 26, 2001

R001981

ISO 9002



Mr. Marty Cieslik
FOTH & VAN DYKE
406 Science Drive
Madison, WI 53711

Dear Mr. Cieslik:

RE: Modern Plating / 97M015

Thank you for consulting Precision Geosynthetic Laboratories for your material testing needs.

It should be noted that the test specimen and test sample used for this report was believed to be representative of the material produced under the designation herein stated. However, these results are indicative of only the specimens that were actually tested. The testing herein is based upon accepted industry practice as well as the test method listed. Precision Geosynthetic Laboratories neither accepts responsibility for nor makes claims to the final use and purpose of the material.

By accepting the data and results represented on this report, Client agrees to limit the liability of Precision Geosynthetic Laboratories from Client and all other parties for claims arising out of the use of this data to the cost for the respective test(s) represented in this report, and Client agrees to indemnify and hold harmless Precision Geosynthetic Laboratories from and against all liability in excess of the aforementioned limit.

The test data and all associated project information shall be held in confidence and disclosed to other parties only with the authorization of Client or Precision Geosynthetic Laboratories.

It is a company policy to keep the physical records of each job for 2 years since the receipt of the samples and keep the electronic file for 7 years. **Failed seam samples are kept for 7 years; good seam samples are disposed after 2 weeks and conformance samples are disposed after 1 month.** Should you need us to keep them longer, please advise us in writing.

If you have any questions or if we may be of further service, please do not hesitate to call at 800-522-4599.

Sincerely,

PRECISION GEOSYNTHETIC LABORATORIES

Edith Pintor
Quality Assurance

Cora B. Queja
Vice President

Enclosure: (Job No. 010057)

1160 North Gilbert Street, Anaheim, CA 92801, Tel # 714-520-9631, Fax # 714-520-9637



Precision Geosynthetic Laboratories

CLIENT: FOTH & VAN DYKE
PROJECT: Modern Plating / 97M015

ISO 9002



VERIFICATION OF MATERIAL PROPERTIES (PGL Job No. 010057)

MATERIAL DESCRIPTION: GCL

SAMPLED BY: FOTH & VAN DYKE OF MADISON

DATE RECEIVED: January 18, 2001

DATE REPORTED: January 26, 2001

SAMPLE IDENTIFICATIONS:

SAMPLE ID	PRECISION CONTROL NUMBER
GCL-13 Roll 1780	69063
GCL-14 Roll 2741	69064
GCL-15 Roll 2749	69065
GCL-16 Roll 2245	69066
GCL-17 Roll 2271	69067
GCL-18 Roll 2745	69068
GCL-19 Roll 1791	69069
GCL-20 Roll 2246	69070
GCL-21 Roll 2748	69071
GCL-22 Roll 1777	69072
GCL-23 Roll 2247	69073
GCL-24 Roll 2270	69074
GCL-25 Roll 1776	69075
GCL-26 Roll 1779	69076

TESTS REQUIRED:

TEST METHOD	DESCRIPTION
ASTM D1777	Thickness
ASTM D5993	Mass Per Unit Area

TEST CONDITIONS: The samples were conditioned for a minimum one hour in the laboratory at $22 \pm 2^{\circ}\text{C}$ ($71.6 \pm 3.6^{\circ}\text{F}$) and at $60 \pm 10\%$ relative humidity prior to test.



Precision Geosynthetic Laboratories

ISO 9002



Page 2.
FOR: FOTH & VAN DYKE
Reference: PGL Job No. 010057
Date: January 26, 2001

TEST RESULTS:

The test results are summarized in Tables 1 through 14. The units in which the data are reported are included on the tables

PRECISION GEOSYNTHETIC LABORATORIES



Edith Pintor
Quality Assurance



Cora B. Queja
Vice President

TABLE 1.
MATERIAL PROPERTIES
CLIENT: FOTH & VAN DYKE
PROJECT: Modern Plating / 97M015

Date Received: 1/18/01
 Date Reported: 1/26/01
 Client Sample ID: GCL-13 Roll 1780
 Material Description: GCL

QC'd By: 
 PGL Job No.: 010057
 PGL Control No.: 69063

		SPECIMENS												
		1	2	3	4	5	6	7	8	9	10	Avg.	Std. Dev.	Proj. Specs.
METHOD	DESCRIPTION													
ASTM D1777	Thickness (in)	0.340	0.339	0.331	0.327	0.328	0.336	0.328	0.340	0.327	0.328	0.332	0.006	0.25 min.
ASTM D5993	Mass per Unit Area of the Clay (lbs/ ft ²)	0.92	0.92									0.92	0.003	0.75 min.

71



Precision Geosynthetic Laboratories

ISO 9002



R001984

TABLE 2.
MATERIAL PROPERTIES
CLIENT: FOTH & VAN DYKE
PROJECT: Modern Plating / 97M015

Date Received: 1/18/01
 Date Reported: 1/26/01
 Client Sample ID: GCL-14 Roll 2741
 Material Description: GCL

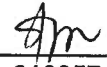
QC'd By: 
 PGL Job No. : 010057
 PGL Control No. : 69064

		SPECIMENS												
		1	2	3	4	5	6	7	8	9	10	Avg.	Std. Dev.	Proj. Specs.
METHOD	DESCRIPTION													
ASTM D1777	Thickness (in)	0.349	0.360	0.366	0.350	0.350	0.365	0.349	0.360	0.363	0.351	0.356	0.007	0.25 min.
ASTM D5993	Mass per Unit Area of the Clay (lbs/ ft ²)	0.91	0.92									0.92	0.001	0.75 min.

72



Precision Geosynthetic Laboratories

ISO 9002



R001985

TABLE 3.
MATERIAL PROPERTIES
CLIENT: FOTH & VAN DYKE
PROJECT: Modern Plating / 97M015

Date Received: 1/18/01
 Date Reported: 1/26/01
 Client Sample ID: GCL-15 Roll 2749
 Material Description: GCL

QC'd By: *[Signature]*
 PGL Job No. : 010057
 PGL Control No. : 69065

		SPECIMENS														
		1	2	3	4	5	6	7	8	9	10	Avg.	Std. Dev.	Proj. Specs.		
METHOD	DESCRIPTION															
ASTM D1777	Thickness (in)	0.358	0.350	0.366	0.364	0.355	0.350	0.365	0.362	0.351	0.362	0.358	0.007	0.25 min.		
ASTM D5993	Mass per Unit Area of the Clay (lbs/ft ²)	0.93	0.93											0.93	0.003	0.75 min.

73



Precision Geosynthetic Laboratories



R001986

TABLE 4.
MATERIAL PROPERTIES
CLIENT: FOTH & VAN DYKE
PROJECT: Modern Plating / 97M015

Date Received: 1/18/01
 Date Reported: 1/26/01
 Client Sample ID: GCL-16 Roll 2245
 Material Description: GCL

QC'd By: 
 PGL Job No. : 010057
 PGL Control No. : 69066

		SPECIMENS													
		1	2	3	4	5	6	7	8	9	10	Avg.	Std. Dev.	Proj. Specs.	
METHOD	DESCRIPTION														
ASTM D1777	Thickness (in)	0.365	0.340	0.346	0.366	0.344	0.340	0.362	0.345	0.364	0.340	0.351	0.011	0.25 min.	
ASTM D5993	Mass per Unit Area of the Clay (lbs/ ft ²)	0.97	1.00										0.98	0.022	0.75 min.

74



Precision Geosynthetic Laboratories

ISO 9002



R001987

TABLE 5.
MATERIAL PROPERTIES
CLIENT: FOTH & VAN DYKE
PROJECT: Modern Plating / 97M015

Date Received: 1/18/01
 Date Reported: 1/26/01
 Client Sample ID: GCL-17 Roll 2271
 Material Description: GCL

QC'd By: 
 PGL Job No. : 010057
 PGL Control No. : 69067

		SPECIMENS												
		1	2	3	4	5	6	7	8	9	10	Avg.	Std. Dev.	Proj. Specs.
METHOD	DESCRIPTION													
ASTM D1777	Thickness (in)	0.328	0.351	0.332	0.347	0.351	0.330	0.328	0.336	0.341	0.339	0.338	0.009	0.25 min.
ASTM D5993	Mass per Unit Area of the Clay (lbs/ ft ²)	0.95	0.94									0.94	0.008	0.75 min

75



Precision Geosynthetic Laboratories

ISO 9002



R001988

TABLE 6.
MATERIAL PROPERTIES
CLIENT: FOTH & VAN DYKE
PROJECT: Modern Plating / 97M015

Date Received: 1/18/01
 Date Reported: 1/26/01
 Client Sample ID: GCL-18 Roll 2745
 Material Description: GCL

QC'd By: 
 PGL Job No.: 010057
 PGL Control No.: 69068

		SPECIMENS												
		1	2	3	4	5	6	7	8	9	10	Avg.	Std. Dev.	Proj. Specs.
METHOD	DESCRIPTION													
ASTM D1777	Thickness (in)	0.365	0.370	0.356	0.359	0.366	0.351	0.364	0.368	0.357	0.361	0.362	0.006	0.25 min.
ASTM D5993	Mass per Unit Area of the Clay (lbs/ ft2)	0.95	0.84									0.89	0.083	0.75 min.

76



Precision Geosynthetic Laboratories

ISO 9002



R001989

TABLE 7.
MATERIAL PROPERTIES
CLIENT: FOTH & VAN DYKE
PROJECT: Modern Plating / 97M015

Date Received: 1/18/01
 Date Reported: 1/26/01
 Client Sample ID: GCL-19 Roll 1791
 Material Description: GCL

QC'd By: *[Signature]*
 PGL Job No. : 010057
 PGL Control No. : 69069

METHOD DESCRIPTION	SPECIMENS										Avg.	Std. Dev.	Proj. Specs.
	1	2	3	4	5	6	7	8	9	10			
ASTM D1777 Thickness (in)	0.350	0.370	0.349	0.356	0.366	0.358	0.350	0.350	0.359	0.363	0.357	0.008	0.25 min.
ASTM D5993 Mass per Unit Area of the Clay (lbs/ ft ²)	0.89	1.01									0.95	0.090	0.75 min.

77



Precision Geosynthetic Laboratories



R001990

TABLE 8.
MATERIAL PROPERTIES
CLIENT: FOTH & VAN DYKE
PROJECT: Modern Plating / 97M015

Date Received: 1/18/01
 Date Reported: 1/26/01
 Client Sample ID: GCL-20 Roll 2246
 Material Description: GCL

QC'd By: 
 PGL Job No. : 010057
 PGL Control No. : 69070

		SPECIMENS												
		1	2	3	4	5	6	7	8	9	10	Avg.	Std. Dev.	Proj. Specs.
METHOD	DESCRIPTION													
ASTM D1777	Thickness (in)	0.335	0.365	0.340	0.348	0.336	0.355	0.363	0.361	0.336	0.342	0.348	0.012	0.25 min.
ASTM D5993	Mass per Unit Area of the Clay (lbs/ft ²)	0.93	0.91									0.92	0.011	0.75 min.

78



Precision Geosynthetic Laboratories

ISO 9002



R001991

TABLE 9.
MATERIAL PROPERTIES
CLIENT: FOTH & VAN DYKE
PROJECT: Modern Plating / 97M015

Date Received: 1/18/01
 Date Reported: 1/26/01
 Client Sample ID: GCL-21 Roll 2748
 Material Description: GCL

QC'd By: 
 PGL Job No. : 010057
 PGL Control No. : 69071

METHOD DESCRIPTION	SPECIMENS										Avg.	Std. Dev.	Proj. Specs.
	1	2	3	4	5	6	7	8	9	10			
ASTM D1777 Thickness (in)	0.357	0.366	0.360	0.356	0.352	0.350	0.349	0.351	0.355	0.360	0.356	0.006	0.25 min.
ASTM D5993 Mass per Unit Area of the Clay (lbs/ ft ²)	0.90	0.98									0.94	0.059	0.75 min.

79



Precision Geosynthetic Laboratories

ISO 9002



R001992

TABLE 10.
MATERIAL PROPERTIES
CLIENT: FOTH & VAN DYKE
PROJECT: Modern Plating / 97M015

Date Received: 1/18/01
 Date Reported: 1/26/01
 Client Sample ID: GCL-22 Roll 1777
 Material Description: GCL

QC'd By: *[Signature]*
 PGL Job No. : 010057
 PGL Control No. : 69072

		SPECIMENS										Avg.	Std. Dev.	Proj. Specs.
		1	2	3	4	5	6	7	8	9	10			
METHOD	DESCRIPTION													
ASTM D1777	Thickness (in)	0.340	0.338	0.329	0.356	0.327	0.324	0.331	0.352	0.334	0.341	0.337	0.010	0.25 min.
ASTM D5993	Mass per Unit Area of the Clay (lbs/ft ²)	0.98	0.92									0.95	0.046	0.75 min

08



Precision Geosynthetic Laboratories

ISO 9002



R001993

TABLE 11.
MATERIAL PROPERTIES
CLIENT: FOTH & VAN DYKE
PROJECT: Modern Plating / 97M015

Date Received: 1/18/01
 Date Reported: 1/26/01
 Client Sample ID: GCL-23 Roll 2247
 Material Description: GCL

QC'd By: 
 PGL Job No.: 010057
 PGL Control No.: 69073

METHOD DESCRIPTION	SPECIMENS										Avg.	Std. Dev.	Proj. Specs.
	1	2	3	4	5	6	7	8	9	10			
ASTM D1777 Thickness (in)	0.341	0.340	0.346	0.339	0.340	0.344	0.338	0.351	0.348	0.353	0.344	0.005	0.25 min.
ASTM D5993 Mass per Unit Area of the Clay (lbs/ ft2)	0.83	0.93									0.88	0.069	0.75 min.

81



Precision Geosynthetic Laboratories



R001994

TABLE 12.
MATERIAL PROPERTIES
CLIENT: FOTH & VAN DYKE
PROJECT: Modern Plating / 97M015

Date Received: 1/18/01
 Date Reported: 1/26/01
 Client Sample ID: GCL-24 Roll 2270
 Material Description: GCL

QC'd By: *[Signature]*
 PGL Job No. : 010057
 PGL Control No. : 69074

METHOD DESCRIPTION	SPECIMENS										Avg.	Std. Dev.	Proj. Specs.
	1	2	3	4	5	6	7	8	9	10			
ASTM D1777 Thickness (in)	0.327	0.340	0.323	0.350	0.336	0.340	0.326	0.325	0.331	0.333	0.333	0.009	0.25 min.
ASTM D5993 Mass per Unit Area of the Clay (lbs/ ft ²)	0.96	0.97									0.97	0.007	0.75 min.

82



Precision Geosynthetic Laboratories

ISO 9002



R001995

TABLE 13.
MATERIAL PROPERTIES
CLIENT: FOTH & VAN DYKE
PROJECT: Modern Plating / 97M015

Date Received: 1/18/01
 Date Reported: 1/26/01
 Client Sample ID: GCL-25 Roll 1776
 Material Description: GCL

QC'd By: 
 PGL Job No. : 010057
 PGL Control No. : 69075

		SPECIMENS										Avg.	Std. Dev.	Proj. Specs.
		1	2	3	4	5	6	7	8	9	10			
METHOD	DESCRIPTION													
ASTM D1777	Thickness (in)	0.326	0.341	0.335	0.330	0.330	0.327	0.340	0.344	0.329	0.331	0.333	0.006	0.25 min.
ASTM D5993	Mass per Unit Area of the Clay (lbs/ft ²)	0.95	0.95									0.95	0.004	0.75 min.

83



Precision Geosynthetic Laboratories

ISO 9002



R001996

TABLE 14.
MATERIAL PROPERTIES
CLIENT: FOTH & VAN DYKE
PROJECT: Modern Plating / 97M015

Date Received: 1/18/01
 Date Reported: 1/26/01
 Client Sample ID: GCL-26 Roll 1779
 Material Description: GCL

QC'd By: 
 PGL Job No. : 010057
 PGL Control No. : 69076

		SPECIMENS										Avg.	Std. Dev.	Proj. Specs.	
		1	2	3	4	5	6	7	8	9	10				
METHOD	DESCRIPTION														
ASTM D1777	Thickness (in)	0.326	0.335	0.321	0.323	0.325	0.337	0.340	0.327	0.328	0.330	0.329	0.006	0.25 min.	
ASTM D5993	Mass per Unit Area of the Clay (lbs/ ft ²)	0.79	0.86										0.83	0.050	0.75 min.

84



Precision Geosynthetic Laboratories

ISO 9002



R001997

CONFORMANCE TEST CHAIN OF CUSTODY FORM

Precision Geosynthetic Laboratories
 1150 North Gilbert Street
 Anaheim, CA 92801
 (800-522-4599)

R001998
 P 06 of 12

PROJECT NAME / PROJECT NUMBER: _____

PROJECT LOCATION: _____

GEOMEMBRANE TESTING

SAMPLE ID	Thickness ASTM D5199 or D564	Density ASTM D1505 or D792	Carbon Black Content ASTM D1003	Carbon Dispersion D3015 / D5536	Tensile ASTM D638 C813 / R15F54	Tear Resistance ASTM D1004 (Die C)	Puncture D4833 /101CN2006	Well Flow Index ASTM D1238, cond E	Dimensional Stability ASTM D1204	Low Temp. Brittleness D746 / D1790	ACIL ASTM D5397 Hours	Other ASTM

NONWOVEN OR WOVEN GEOTEXTILE TESTING

SAMPLE ID	Thickness ASTM D5109 or D1177	Mass Per Area ASTM D5261 or D3776	Grab Tensile ASTM D4632	Trapezoid Tear ASTM D4533	Puncture Resistance ASTM D4830	Mullen Burst ASTM D3778	Permeability ASTM D4491	AOS ASTM D4751	Wide Width Tensile ASTM D4586	UV (hrs) ASTM D4359	Other ASTM	Other ASTM

GEOCOMPOSITE / GEONET / GEOGRID TESTING

SAMPLE ID	Thickness ASTM D5169 or D1777	Density ASTM D1505 or D792	Carbon Black Content ASTM D1003	Fibers Per Area ASTM D5261 or D3776	Well Flow Index ASTM D1238, cond E	Puncture ASTM D4113, F904 or GRI-GC7	Transmissivity* ASTM D4716	Compression ASTM D1621	Tensile Strength ASTM D1082 or D5035	Wide Width Tensile ASTM D4595	Rub Tensile Strength GRI-GG1	Junction Strength GRI-GG2

* Transmissivity Test Parameters: Normal Load _____ Gradient _____ Sealing Time _____ Boundary Condition _____

GCL TESTING

SAMPLE ID	Thickness ASTM D5199	Mass Per Area ASTM D5261	Grab Tensile ASTM D4632	Peel Strength ASTM D1082	Moisture Content ASTM D4643 or D2718	Hydraulic Conductivity ASTM D5084	Index Flux ASTM D5687	Swell Index ASTM D5690	Fluid Loss ASTM D5691	Infrared Strength ASTM D6245	Other ASTM	Other ASTM
GCL-12 (Roll # 2747)	✓	✓										
GCL-13 (Roll # 1780)	✓	✓										

SEND REPORT TO:

Name: _____
 Company: _____
 Address: _____
 Phone: _____
 Fax: _____
 e-mail: _____

FIELD CONTACT

Name: _____
 Pager: _____
 Mobile: _____
 Phone: 85 _____
 Fax: _____
 e-mail: _____

Released by:

Name: _____
 Date/Time: _____
 Received by:
 Name: **MARLA**
 PGL
 Date: 1/18/01

Shipped Via:

- Feder
- UPS
- Airborne
- DHL
- JS Mail
- Other

CONFORMANCE TEST CHAIN OF CUSTODY FORM 001999

Precision Geosynthetic Laboratories
 1150 North Gilbert Street
 Anaheim, CA 92801
 (800-522-4599)

Page 7 of 12

PROJECT NAME / PROJECT NUMBER: _____

PROJECT LOCATION: _____

GEOMEMBRANE TESTING

SAMPLE ID	Thickness ASTM D5149 or D5644	Density ASTM D1505 or D797	Carbon Black Content ASTM D1600	Carbon Dispersion D3015 / D5596	Tensile ASTM D638 G.M. / HSF54	Tear Resistance ASTM D1004 (Dia C)	Puncture D4833 /101GM2026	Melt Flow Index ASTM D1238, cond E	Dimensional Stability ASTM D1204	Low Temp. Brittleness D746 / D1790	ECTL ASTM D6397 Hours	Other ASTM

NONWOVEN OR WOVEN GEOTEXTILE TESTING

SAMPLE ID	Thickness ASTM D5109 or D1777	Mass Per Area ASTM D5261 or D3776	Grab Tensile ASTM D4632	Trapezoid Tear ASTM D4533	Puncture Resistance ASTM D4833	Mullen Burst ASTM D3776	Permeability ASTM D4491	AOS ASTM D4751	Wide Width Tensile ASTM D4596	UV (hrs) ASTM D4359	Other ASTM	Other ASTM

GEOCOMPOSITE / GEONET / GEOGRID TESTING

SAMPLE ID	Thickness ASTM D5149 or D1777	Density ASTM D1505 or D797	Carbon Black Content ASTM D1600	Mass Per Area ASTM D5261 or D3776	Melt Flow Index ASTM D1238, cond E	Peel ASTM D113, F904 or GRI-GG7	Transmissivity ASTM D4716	Compression ASTM D1621	Tensile Strength ASTM D1087 or D5035	Wide Width Tensile ASTM D4595	Rob Tensile Strength GRI-GG1	Junction Strength GRI-GG2

* Transmissivity Test Parameters: Normal Load _____ Gradient _____ Sealing Time _____ Boundary Condition _____

GCL TESTING

SAMPLE ID	Thickness ASTM D5199	Mass Per Area ASTM D5261	Grab Tensile ASTM D4632	Peel Strength ASTM D806	Moisture Content ASTM D4643 or D2216	Hydraulic Conductivity ASTM D5684	Index Falt ASTM D5687	Swell Index ASTM D5890	Fluid Loss ASTM D5691	Infrared Absorbance Strength ASTM D6743	Other ASTM	Other ASTM
GCL-14 (Roll # 2741)	✓	✓										
GCL-15 (Roll # 2749)	✓	✓										

SEND REPORT TO:

Name: _____
 Company: _____
 Address: _____
 Phone: _____
 Fax: _____
 e-mail: _____

FIELD CONTACT:

Name: _____
 Paper: _____
 Mail: _____
 Phone: _____
 Fax: _____
 e-mail: _____

Received by:

Name: _____
 Date/Time: _____
 Received by: MARIA E.
 PCL
 1/18/01

Shipped Via:

FedEx
 UPS
 Airborne
 DHL
 US Mail

CONFORMANCE TEST CHAIN OF CUSTODY FORM #000

Precision Geosynthetic Laboratories
 1150 North Gilbert Street
 Anaheim, CA 92801
 (800-522-4599)

PROJECT NAME / PROJECT NUMBER: _____

PROJECT LOCATION: _____

Page 2 of 12

GEOMEMBRANE TESTING

SAMPLE ID	Thickness ASTM D5199 or D5694	Density ASTM D1505 or D792	Carbon Black Content ASTM D1600	Carbon Dispersion D3015/ D5506	Tensile ASTM D638 GRI13 / NSF54	Tear Resistance ASTM D1004 (Dia C)	Puncture D4833 /101CM2006	Melt Flow Index ASTM D1238, cond E	Dimensional Stability ASTM D1204	Low Temp. Britleness D746/ D1790	MCTL ASTM D5397 Hours _____	Other ASTM _____

NONWOVEN OR WOVEN GEOTEXTILE TESTING

SAMPLE ID	Thickness ASTM D5109 or D1777	Mass Per Area ASTM D5261 or D3776	Grab Tensile ASTM D4532	Trapezoid Tear ASTM D4533	Puncture Resistance ASTM D4833	Mullen Burst ASTM D3778	Permeability ASTM D4491	AOS ASTM D4751	Wide Width Tensile ASTM D4595	UV (hrs) ASTM D4359	Other ASTM _____	Other ASTM _____

GEOCOMPOSITE / GEOWEB / GEOGRID TESTING

SAMPLE ID	Thickness ASTM D5169 or D1777	Density ASTM D1505 or D792	Carbon Black Content ASTM D1600	Mass Per Area ASTM D5261 or D3776	Melt Flow Index ASTM D1238, cond E	Poel ASTM D413, F904 or GRI-GC7	Transmissivity ASTM D4716	Compression ASTM D1621	Tensile Strength ASTM D1682 or D5035	Wide Width Tensile ASTM D4595	Rb Tensile Strength GRI-GG1	Junction Strength GRI-GG2

• Transmissivity Test Parameters: Normal Load _____

Gradient _____

Safety Time _____

Boundary Condition _____

GCL TESTING

SAMPLE ID	Thickness ASTM D5199	Mass Per Area ASTM D5693	Grab Tensile ASTM D4532	Poel Strength ASTM D8496	Moisture Content ASTM D4643 or D2216	Hydraulic Conductivity ASTM D5084	Index Flux ASTM D5687	Swell Index ASTM D5890	Fluid Loss ASTM D5691	Internal Shear Strength ASTM D6249	Other ASTM _____	Other ASTM _____
GCL-16 (Roll #2245)	✓	✓										
GCL-17 (Roll #2271)	✓	✓										

SEND REPORT TO: _____

FIELD CONTACT _____

Requested by: _____

Shipped via: _____

Name _____

O FedEx

Company _____

O UPS

Address _____

City/Time _____

O Airborne

Phone _____

Received by: _____

O Other

Fax _____

Name _____

O US Mail

PGI _____

O Other

87

11/8/01

CONFORMANCE TEST CHAIN OF CUSTODY FORM

Precision Geosynthetic Laboratories
 1150 North Gilbert Street
 Anaheim, CA 92801
 (800-522-4599)

R002001
 Page 9 of 12

PROJECT NAME / PROJECT NUMBER: _____

PROJECT LOCATION: _____

GEOMEMBRANE TESTING

SAMPLE ID	Thickness ASTM D5199 or D5641	Density ASTM D1505 or D792	Carbon Black Content ASTM D1600	Carbon Dispersions D3015/D5596	Tensile ASTM D638 or GR13 / R15F54	Tear Resistance ASTM D1004 (Din C)	Puncture D4833 /101CM206	Well Flow Index ASTM D1238, cond E	Dimensional Stability ASTM D1204	Low Temp. Brittleness D748/ D1790	FCIL ASTM D6397 Hours	Other ASTM

NONWOVEN OR WOVEN GEOTEXTILE TESTING

SAMPLE ID	Thickness ASTM D5199 or D1777	Mass Per Area ASTM D5261 or D3776	Grab Tensile ASTM D4632	Trapezoid Tear ASTM D4533	Puncture Resistance ASTM D4833	Inclined Burst ASTM D3778	Permeability ASTM D4491	AOS ASTM D4751	Wide Width Tensile ASTM D4586	UV (hrs) ASTM D4359	Other ASTM	Other ASTM

GEOCOMPOSITE / GEONET / GEOGRID TESTING

SAMPLE ID	Thickness ASTM D5169 or D1777	Density ASTM D1505 or D792	Carbon Black Content ASTM D1600	Mass Per Area ASTM D5261 or D3776	Well Flow Index ASTM D1238, cond E	Puncture ASTM D4112, F904 or GRI-GC7	Transmissivity* ASTM D4716	Compression ASTM D1621	Tensile Strength ASTM D1082 or D5035	Wide Width Tensile ASTM D4595	Rb Tensile Strength GRI-GG1	Junction Strength GRI-GG2

* Transmissivity Test Parameters: Normal Load: _____ Gradient: _____ Sealing Time: _____ Boundary Condition: _____

GCL TESTING

SAMPLE ID	Thickness ASTM D5199	Mass Per Area ASTM D5261	Grab Tensile ASTM D4632	Peel Strength ASTM D1082	Moisture Content ASTM D4643 or D2216	Hydraulic Conductivity ASTM D5084	Index Flux ASTM D5687	Swell Index ASTM D5890	Fluid Loss ASTM D5691	Inclined Burst Strength ASTM D6245	Other ASTM	Other ASTM
GCL-18 (Roll # 2745)	✓	✓										
GCL-19 (Roll # 1791)	✓	✓										

SEND REPORT TO:

Name: _____
 Company: _____
 Address: _____
 Phone: _____
 Fax: _____
 e-mail: _____

FIELD CONTACT

Name: _____
 Pager: _____
 Mobile: _____
 Phone: _____
 Fax: _____
 e-mail: _____

Released by:

Name: _____
 Date/Time: _____
 Received by:
 Name: **MARIA E.**
 PCL
 Date: **Y18/01**

Shipped Via:

FedEx
 UPS
 Airborne
 DHL
 JS Mail
 Other

CONFORMANCE TEST CHAIN OF CUSTODY FORM

Form 9002

Page 12 of 12

Precision Geosynthetic Laboratories

1150 North Gilbert Street

Ararham, CA 92801

(800-522-4599)

PROJECT NAME / PROJECT NUMBER:

PROJECT LOCATION:

GEOMEMBRANE TESTING

SAMPLE ID	Thickness ASTM D5199 or D5771	Density ASTM D1505 or D792	Carbon Black Content ASTM D1600	Carbon Dispersion D3015/ D5596	Tensile ASTM D638 GRI 13 / NSF 54	Tear Resistance ASTM D1004 (Dia C)	Puncture D4833 1101CM2006	Melt Flow Index ASTM D1238, cond E	Dimensional Stability ASTM D1204	Low Temp. Brittleness D746/ D1790	MCTL ASTM D5397 Hours	Other ASTM

NONWOVEN OR WOVEN GEOTEXTILE TESTING

SAMPLE ID	Thickness ASTM D5199 or D1777	Mass Per Area ASTM D5261 or D3776	Grab Tensile ASTM D4532	Trapezoid Tear ASTM D4533	Puncture Resistance ASTM D4833	Mullen Burst ASTM D3778	Permeability ASTM D4491	AOS ASTM D4751	Wide Width Tensile ASTM D4595	UV (hrs) ASTM D4359	Other ASTM	Other ASTM

GEOTEXTILE / GEONET / GEOGRID TESTING

SAMPLE ID	Thickness ASTM D5169 or D1777	Density ASTM D1505 or D792	Carbon (Black) Content ASTM D1603	Mass Per Area ASTM D5261 or D3776	Melt Flow Index ASTM D1238, cond E	Peel ASTM D413, F904 or GRI-GC7	Transmissivity ASTM D4716	Compression ASTM D1621	Tensile Strength ASTM D1002 or D5035	Wide Width Tensile ASTM D4595	Rob Tensile Strength GRI-GG1	Junction Strength GRI-GG2

* Transmissivity Test Parameters: Normal Load

Gradient Sealing Time Boundary Condition

GCL TESTING

SAMPLE ID	Thickness ASTM D5199	Mass Per Area ASTM D5693	Grab Tensile ASTM D4532	Peel Strength ASTM D1006	Moisture Content ASTM D4643 or D2216	Hydraulic Conductivity ASTM D5084	Index Flux ASTM D5687	Swell Index ASTM D5890	Fluid Loss ASTM D5691	Internal Shear Strength ASTM D6249	Other ASTM	Other ASTM
GCL-20 (Roll #2246)	✓	✓										
GCL-21 (Roll #2748)	✓	✓										

SEND REPORT TO:

FIELD CONTACT

Name: _____
Company: _____
Address: _____
Phone: _____
Fax: _____
E-Mail: _____

Name: _____
Paper: _____
Phone: _____
Fax: _____
E-Mail: _____

89

Received by: MARIA
Date: 1/18/01

Ship Via: _____
O Fed _____
O US _____
O Air _____
O Other _____

PGI
Date: 1/18/01
SWS

CONFORMANCE TEST CHAIN OF CUSTODY FORM 2003

Precision Geosynthetic Laboratories
1150 North Gilbert Street
Anaheim, CA 92801

(800-522-4599)

Page 12 of 12

PROJECT NAME / PROJECT NUMBER: _____

PROJECT LOCATION: _____

GEOMEMBRANE TESTING

SAMPLE ID	Thickness ASTM D5199 or D5644	Density ASTM D1505 or D792	Carbon Black Content ASTM D1600	Carbon Dispersion D3015 / D5596	Tensile ASTM D638 GMB / MSF51	Tear Resistance ASTM D1004 (Dia C)	Puncture D4833 /101CM2006	Melt Flow Index ASTM D1238; cond E	Dimensional Stability ASTM D1204	Low Temp. Brittleness D746 / D1790	PCTI ASTM D6397 Hours	Other ASTM

NONWOVEN OR WOVEN GEOTEXTILE TESTING

SAMPLE ID	Thickness ASTM D5199 or D3777	Mass Per Area ASTM D5261 or D3776	Grab Tensile ASTM D4632	Trapezoid Tear ASTM D4533	Puncture Resistance ASTM D4833	Kulén Burn ASTM D3778	Permittivity ASTM D4491	AOS ASTM D4751	Wrink Width Tensile ASTM D4506	UV (hrs) ASTM D4359	Other ASTM	Other ASTM

GEOCOMPOSITE / GEONET / GEOGRID TESTING

SAMPLE ID	Thickness ASTM D5169 or D1777	Density ASTM D1505 or D792	Carbon Black Content ASTM D1600	Mass Per Area ASTM D5261 or D3776	Melt Flow Index ASTM D1238; cond E	Pool ASTM D412, F904 or GRI GC7	Transmissivity ASTM D4716	Compression ASTM D1621	Tensile Strength ASTM D1082 or D5035	Wide Width Tensile ASTM D4599	Rb Tensile Strength GRI GC1	Junction Strength GRI GC2

* Transmissivity Test Parameters: Normal Load _____ Gradient _____ Sealing Time _____ Boundary Condition _____

GCL TESTING

SAMPLE ID	Thickness ASTM D5199	Mass Per Area ASTM D5693	Grab Tensile ASTM D4632	Peel Strength ASTM D1082	Moisture Content ASTM D4843 or D2116	Hydraulic Conductivity ASTM D5084	Index Flux ASTM D5087	Swell Index ASTM D5890	Fluid Loss ASTM D4891	Internal Shear Strength ASTM D6749	Other ASTM	Other ASTM
GCL-02 (Roll # 1777)	✓	✓										
GCL-03 (Roll # 2247)	✓	✓										

SEND REPORT TO:

Name: _____
Company: _____
Address: _____
Phone: _____
Fax: _____
E-mail: _____

FIELD CONTACT

Name: _____
Pager: _____
Mail: _____
Phone: _____
Fax: _____
E-mail: _____

Received by:

Name: _____
Date/Time: _____
Received by: _____
Name: MARIA E.
PGL
Date: 1/18/01

Shipped Via:

FedEx
 UPS
 Airborne
 DHL
 USPS
 Other

CONFORMANCE TEST CHAIN OF CUSTODY FORM 002004

Precision Geosynthetic Laboratories
 1160 North Gilbert Street
 Anaheim, CA 92801
 (800-522-4599)

PROJECT NAME / PROJECT NUMBER: _____
 PROJECT LOCATION: _____

MEMBRANE TESTING

SAMPLE ID	Thickness ASTM D5199 or D5694	Density ASTM D1505 or D792	Carbon Black Content ASTM D1603	Carbon Dispersion D3015/ D5596	Tensile ASTM D638 GM13 / NSF54	Tear Resistance ASTM D1004 (Die C)	Puncture D4833 /101CM2006	Melt Flow Index ASTM D1238, cond E	Dimensional Stability ASTM D1204	Low Temp. Brittleness D746/ D1790	NCTL ASTM D6397	Hours	Other

NONWOVEN OR WOVEN GEOTEXTILE TESTING

SAMPLE ID	Thickness ASTM D5199 or D1777	Mass Per Area ASTM D5261 or D3776	Grab Tensile ASTM D4632	Trapezoid Tear ASTM D4533	Puncture Resistance ASTM D4833	Mullen Burst ASTM D3778	Permeability ASTM D4491	AOS ASTM D4751	Wide Width Tensile ASTM D4596	UV (hrs) ASTM D4359	Other	Other

GEOCOMPOSITE / GEONET / GEOGRID TESTING

SAMPLE ID	Thickness ASTM D5169 or D1777	Density ASTM D1505 or D792	Carbon Black Content ASTM D1603	Mass Per Area ASTM D5261 or D3776	Melt Flow Index ASTM D1238, cond E	Pool ASTM D413, F904 or GRI-GC7	Transmissivity * ASTM D4716	Compression ASTM D1621	Tensile Strength ASTM D1682 or D5035	Wide Width Tensile ASTM D4596	Rib Tensile Strength GRI-GG1	Junction Strength GRI-GG2

* Transmissivity Test Parameters: Normal Load _____ Gradient _____ Sealing Time _____ Boundary Condition _____

GCL TESTING

SAMPLE ID	Thickness ASTM D5199	Mass Per Area ASTM D5693	Grab Tensile ASTM D4632	Pool Strength ASTM D8496	Moisture Content ASTM D4643 or D2216	Hydraulic Conductivity ASTM D5084	Index Flux ASTM D5687	Swell Index ASTM D5690	Fluid Loss ASTM D5691	Internal Shear Strength ASTM D6243	Other	Other
GCL-26 24 (Roll # 237D)	✓	✓										
GCL-25 (Roll # 1776)	✓	✓										
GCL-26 (Roll # 1779)	✓	✓										

SEND REPORT TO: (Roll # 1779)

FIELD CONTACT:

Requested by: _____
 Date/Time: _____

Company: _____
 Address: _____
 Phone: _____
 Fax: _____
 E-mail: _____

Name: _____
 Title: _____

Received by: N. RIA E.
 Date/Time: 1/18/01

Shipped via:
 Fedex
 UPS
 Airborne
 DHL
 US Mail
 Other

Appendix C4

GCL Panel Placement Summary Forms

PANEL PLACEMENT SUMMARY

PP -

Project Name: MDC - Final Cover

Page 1 of 2

Project No: 97M015

Date: 1/13/01

Computer Entry By: _____

Installer: MIDESA (TERRA Subcontractor)

Checked By: _____

Panel Number	Roll Number/ Material Type	Panel Location	Time Deployed	Weather	QA Monitor	Panel Damage (y/n)	Subgrade Conditions	Length/ Width (feet)	Comments
				Temp./Wind/ Precip.					
GCL-1	? /	Final Cover	1/12/01?	35°F / calm			See Comments	15' / 150'	SAND layer frozen however could not get on upper 2-3"
GCL-2	? /			40°F Foggy				15' / 150'	late snow on sand
GCL-3	? /							15' / 150'	
GCL-4	2739 / GCL		8:00		REM	N		15' / 150'	
GCL-5	2737 / GCL		8:40		REM	N		15' / 150'	
GCL-6	2736 / GCL		9:00		REM	N		15' / 150'	
GCL-7	2743 / GCL		9:55		REM	N		15' / 158'	
GCL-8	2744 / GCL		10:15		REM	N		15' / 56'	
GCL-9	2744 / GCL		10:20		REM	N		15' / 77'	
GCL-10	2744 / GCL		10:35		REM	N		15' / 18'	
GCL-11	2742 / GCL		10:50		REM	N		15' / 60'	A few frozen 2'x1' areas along the outside of the panel
GCL-12	2742 / GCL		11:05		REM	N		15' / 83'	
GCL-13	2738 / GCL		12:22		REM	N		15' / 122'	
GCL-14	2746 / GCL		13:20		REM	N		15' / 150'	
GCL-15	2747 / GCL		14:05		REM	N		15' / 75'	
GCL-16	2747 / GCL		14:35		REM	N		7.5' / 75'	
GCL-17	2747 / GCL		14:40		REM	N		7.5' / 75'	
GCL-18	1780 / GCL		15:07		REM	N		15' / 75'	
GCL-19	1780 / GCL		15:20		REM	N		15' / 75'	
GCL-20	2741 / GCL		15:45		REM	N		15' / 75'	
GCL-21	2741 / GCL		16:10		REM	N		15' / 75'	
GCL-22	2749 / GCL		16:15		REM	N		15' / 86'	

93

R002006

1/14/01

1/14/01

PANEL PLACEMENT SUMMARY

PP -

Project Name: MPC-FINAL COVER

Page 2 of 2

Project No: 97M015

Date: 1/13/01 and 1/14/01

Computer Entry By:

Installer: MIDESSA

Checked By:

Panel Number	Roll Number/ Material Type	Panel Location	Time Deployed	Weather	QA Monitor	Panel Damage (y/n)	Subgrade Conditions	Length/ Width (feet)	Comments	
				Temp./Wind/ Precip.						
GCL-23	2245/GCL	FINAL COVER	16:40		REM	N	WET	15'/150'		
GCL-24	2749/GCL		16:45		REM	N	↓	15'/17'		
				Light Snow DIZZLE/D						
GCL-25	2271/GCL		8:45	33-35°F	REM	N	WET	15'/150'	GCL has small (1'x2') spots along the edge, wind damage	
GCL-26	2749/GCL		8:45		REM	N		15'/150'	Light Snow - 33°F	
GCL-27	2745/GCL		9:00		REM	N		15'/10'		
GCL-28	2745/GCL		9:10		REM	N		15'/150'		
GCL-29	1791/GCL		9:25		REM	N		15'/45'		
GCL-30	1791/GCL		10:21		REM	N		15'/105'		
GCL-31	2749/GCL		10:30		REM	N		15'/85'	SNOW STOPS	
GCL-32	2246/GCL		11:31		REM	N		15'/65'		
GCL-33	2748/GCL		11:43		REM	N		15'/126'		
GCL-34	1777/GCL		12:05		REM	N		15'/150'		
GCL-35	2247/GCL		12:15		REM	N		15'/150'		
GCL-36	2270		13:35		BTSI			15'/150'	LIGHT RAIN	
GCL-37	1796		14:15					15'/40'		
GCL-38	?		14:20					15'/41'		
GCL-39	1776		15:15					7.5'/148'		
GCL-40	1779		15:40					7.5'/42'		
GCL-41	↓		15:45					15'/40'		

94

R002007

Appendix D

Geomembrane Material Information

- D1 - Geomembrane Roll Inventory Form**
- D2 - Manufacturer's Roll Test Data Reports**
- D3 - Manufacturer's Resin Quality Assurance Test Results**

Appendix D1
Geomembrane Roll Inventory Form

Appendix D2
Manufacturer's Roll Test Data Reports



2801 Marie-Victorin Blvd, Varennes, Quebec, Canada J3X 1P7
Phone: (450) 929-1234 Fax (450) 929-2548

May 17, 2000

Benjamin Velasquez
Midessa Geomembranes
4809 West 42nd
Odessa, TX 79764

Dear Mr. Velasquez,

Solmax International hereby certifies that Solmax 460T, 60 mil textured HDPE geomembrane, and Solmax 440T, 40 mil textured geomembrane, both meet the properties outlined on pages 02070-5 to 02070-6 for the Modern Plating Facility project in Freeport, IL

Solmax does take exception to the Friction Resistance properties, ASTM D5321 and ASTM D321. These properties can only be certified to once the liner has been tested.

Please feel free to call us at (800) 571-3904 if you have any questions or require additional information.

Sincerely,

A handwritten signature in black ink, appearing to read "Guylaine Chayer". The signature is fluid and cursive, with a long vertical stroke extending upwards from the end of the name.

Guylaine Chayer
Quality Control Supervisor
Solmax International

TECHNICAL DATA SHEET
Textured HDPE
Geomembrane



MODERN PLATING FACILITY, FREEPORT, IL

Properties	Test Method	Frequency *	Solmax 440T
			English Units
Thickness, Minimum Average	ASTM D5994	Every Roll	40 mil
Standard Roll Dimensions [†]	N/A	N/A	22' X 780'
Resin Density	ASTM D1505	Once per Batch	0.94g/cc
Melt Index	ASTM D1238 Condition E	Once per Batch	0.4 g/10 minutes
Oxidative Induction Time	ASTM D3895	Once per Batch	> 100 minutes
Sheet Density	ASTM D1505	Every Other Roll	> 0.940 g/cc
Asperity Height	GRI-GM12	Every Roll	> 10 mil
Carbon Black Content	ASTM D4218	Every Other Roll	2.0 to 3.0 %
Carbon Black Dispersion (10 views)	ASTM D5596	Every Sixth Roll	Category 1 or 2
Tensile Strength - Yield Strength - Yield Elongation (1.3 in. Gage Length) - Break Strength - Break Elongation (2 in. Gage Length)	ASTM D638 Type IV	Every Other Roll	105 lb/in 13 % 75 lb/in 150 %
Tear Resistance	ASTM D1004	Every Sixth Roll	35lbs
Puncture Resistance	ASTM D4833	Every Sixth Roll	75 lbs.
Puncture Resistance	FTMS 101C	Upon Request	38 lbs.
Stress Crack Resistance (SP-NCTL)	ASTM D5397 (Appendix)	Once per Batch	> 200 hrs (BAM Modified)
Dimensional Stability	ASTM D1204	Every Sixth Roll	± 2 %
Low Temperature Brittleness	ASTM D746	Certified	- 112 °F
Oven Aging (at 85°C, Standard OIT, % retained after 90 days)	ASTM D5721	Per Formulation	55 %
U.V. Resistance (High Pressure OIT, % Retained after 1600 hrs)	GRI-GM11	Per Formulation	60 %

* Testing frequency based on standard roll dimensions.

† Roll length may vary ±1%

International Head Office

2801 Marie-Victorin Blvd. • Varennes, Quebec, Canada J3X 1P7
 Tel.: (450) 929-1234 • Fax: (450) 929-1227 • Web: www.solmax.com

Other Offices

Canada: 800 267-1232 USA: 800 571-3904 France: 01.30.15.05.46 Chile: 562 263-1739

Data provided for informational purposes only.

08/99

Appendix D3

Manufacturer's Resin Quality Assurance Test Results

4/13/00



March 27, 2000

G Chayer
Solmax Int'l
2801 Blv.
Marie Victorin
Varenes, PQ J3X1P

CERTIFICATE OF ANALYSIS

Product:	9642	Lot Number:	K021378
Chevron Order #:	250219 - 13000	Destination:	Varenes
Package:	GOCX058420	Weight (lbs):	173,750
Customer Order #:	PON1372	Ship Date:	3/24/00

Following is the data on the subject material as determined by the Quality Control Department:

<u>Property</u>	<u>Value</u>	<u>Units</u>
Melt Index	0.15	gms/10 min
HLMI	13.6	gms/10 min
Density	0.9373	gms/cc
OIT	141.4	

The data set forth herein has been carefully compiled by Chevron Chemical Company. However, there is no warranty of any kind, either expressed or implied, applicable to its use and the user assumes all risk and liability in connection therewith.

Sincerely,

Gary MacMurtrie
Supervisor
Quality Control

13 Avril 00

Customer Fax: 450-929-2548

For inquiry, contact Customer Service at the following number:
Film, Coating, Pipe Applications: 1-800-231-3826
Molding Applications: 1-800-231-3828

Appendix E

Geomembrane Conformance Laboratory Test Results from Precision Geosynthetic Laboratories, Inc.



Precision Geosynthetic Laboratories

December 18, 2000

Mr. Marty Cieslik
FOTH & VAN DYKE
 406 Science Drive
 Madison, WI 53711

Dear Mr. Cieslik:

RE: Modern Plating / 97M015

Thank you for consulting Precision Geosynthetic Laboratories for your material testing needs.

It should be noted that the test specimen and test sample used for this report was believed to be representative of the material produced under the designation herein stated. However, these results are indicative of only the specimens that were actually tested. The testing herein is based upon accepted industry practice as well as the test method listed. Precision Geosynthetic Laboratories neither accepts responsibility for nor makes claims to the final use and purpose of the material.

By accepting the data and results represented on this report, Client agrees to limit the liability of Precision Geosynthetic Laboratories from Client and all other parties for claims arising out of the use of this data to the cost for the respective test(s) represented in this report, and Client agrees to indemnify and hold harmless Precision Geosynthetic Laboratories from and against all liability in excess of the aforementioned limit.

The test data and all associated project information shall be held in confidence and disclosed to other parties only with the authorization of Client or Precision Geosynthetic Laboratories.

It is a company policy to keep the physical records of each job for 2 years since the receipt of the samples and keep the electronic file for 7 years. ***Failed seam samples are kept for 7 years; good seam samples are disposed after 2 weeks and conformance samples are disposed after 1 month.*** Should you need us to keep them longer, please advise us in writing.

If you have any questions or if we may be of further service, please do not hesitate to call at 800-522-4599.

Sincerely,

PRECISION GEOSYNTHETIC LABORATORIES

 Edith Pintor
 Quality Assurance

 Cora B. Queja
 Vice President

Enclosure: (Job No. 001630)

1160 North Gilbert Street, Anaheim, CA 92801, Tel # 714-520-9631, Fax # 714-520-9637



Precision Geosynthetic Laboratories

CLIENT: FOTH & VAN DYKE
PROJECT: Modern Plating / 97M015

VERIFICATION OF MATERIAL PROPERTIES
(PGL Job No. 001630)

MATERIAL DESCRIPTION: Textured Geomembrane - Final Cover

SAMPLED BY: FOTH & VAN DYKE

DATE RECEIVED: December 14, 2000

DATE REPORTED: December 18, 2000

SAMPLE IDENTIFICATIONS:

SAMPLE ID	PRECISION CONTROL NUMBER
17269-1	68651

TESTS REQUIRED:

TEST METHOD	DESCRIPTION
ASTM D5994	Thickness
GRI-GM12	Asperity Height of Textured
ASTM D1505	Density
ASTM D638, Type IV	Tensile Properties
ASTM D1004, Die C	Tear Resistance
ASTM D4833	Puncture Resistance
ASTM D1603	Carbon Black Content
ASTM D5596	Carbon Black Dispersion
ASTM D1238, Cond. 190°C/2.16 kg	Melt Flow Index

TEST CONDITIONS: The sample was conditioned for a minimum one hour in the laboratory at $22 \pm 2^{\circ}\text{C}$ ($71.6 \pm 3.6^{\circ}\text{F}$) and at $60 \pm 10\%$ relative humidity prior to test.

TEST RESULTS:

The test results are summarized in Table 1. The units in which the data are reported are included on the table.

PRECISION GEOSYNTHETIC LABORATORIES



Edith Pintor
Quality Assurance

Cora B. Queja
Vice President

1160 North Gilbert Street, Anaheim, CA 92801, Tel # 714-520-9631, Fax # 714-520-9637

TABLE 1.
MATERIAL PROPERTIES
CLIENT: FOTH & VAN DYKE
PROJECT: Modern Plating / 97M015

Date Received: 12/14/00
 Date Reported: 12/18/00
 Client Sample ID: 17269-1
 Material Description: Textured Geomembrane - Final Cover

QC'd By: 
 PGL Job No.: 001630
 PGL Control No.: 68651

SPECIMENS

	1	2	3	4	5	6	7	8	9	10	Avg.	Std. Dev.	Proj. Specs.
METHOD DESCRIPTION													
ASTM D5994 Thickness (mils)	41.7	42.7	41.8	42.6	43.1	41.7	41.9	43.1	41.9	41.9	42.2	0.6	38
GRI-GM12 Asperity Height of Textured (mils)	17.0	18.0	17.0	19.0	17.0	19.0	20.0	17.0	18.0	19.0	18.1	1.1	MARV 10
ASTM D1505 Density (grams/ cm. ³)	0.9454	0.9454	0.9454								0.9454	0.0000	MARV 0.94 min.
ASTM D638 Type IV <u>Tensile Properties:</u>													
Tensile Strength at Yield (lbs/ in.-width)													
MD	121	118	125	127	117					122	5	105 min.	
TD	119	123	122	123	120					121	2		
Tensile Strength at Break (lbs/ in.- width)													
MD	140	144	155	143	159					148	8	75 min.	
TD	92	142	134	109	110					117	20		
Tensile Elongation at Yield (percent)													
MD	18.6	16.6	18.5	18.8	19.8					18.5	1.2	12 min.	
TD	14.6	16.8	17.5	16.1	17.2					16.4	1.1		
Tensile Elongation at Break (percent) Gauge Length = 2.0 in.													
MD	493	515	505	481	577					514	37	100 min.	
TD	359	534	498	414	411					443	71		
ASTM D1004 Die C Tear Resistance (lbs)													
MD	40	41	41	41	40	41	39	43	36	39	40	2	35 min.
TD	36	43	42	35	37	40	41	36	43	35	39	3	
ASTM D4833 Puncture Resistance (lbs)													
	135	131	130	129	128	135	137	128	127	125	130	3	75 min.
	130	135	128	129	127								
ASTM D1603 Carbon Black Content (percent)													
	2.44	2.57								2.50	0.09	2.0 - 3.0	
ASTM D5596 Carbon Black Dispersion (category rating per reference chart PCN: 12-455960-38)													
	1	1	1	1	1	1	1	1	1	1	1	N/A	1, 2 or 3
ASTM D1238 Melt Flow Index (grams/ 10 minutes) Cond. 190°C/2.16 kg	0.1943	0.1971	0.1954								0.1956	0.0014	0.4 max.

MD - MACHINE DIRECTION
 TD - TRANSVERSE DIRECTION



Precision Geosynthetic Laboratories

R002019

CONFORMANCE TEST CHAIN OF CUSTODY FORM

R002020

Precision Geosynthetic Laboratories
1160 North Gilbert Street
Anaheim, CA 92801

(800-522-4599)

PROJECT NAME / PROJECT NUMBER: MODERN PLATING CORP 19711015
PROJECT LOCATION: FEEDPORT, IL

Page 1 of 1

GEOMEMBRANE TESTING

SAMPLE ID	Thickness ASTM D5199 or D5994	Density ASTM D1505 or D792	Carbon Black Content ASTM D1603	Carbon Dispersion D3015/ D5596	Tensile ASTM D638 GM13 / NSF54	Tear Resistance ASTM D1004 (Die C)	Puncture D4833 / D1CM2066	Melt Flow Index ASTM D1238, cond E	Dimensional Stability ASTM D1204	Low Temp. Brittleness D746/ D1790	NCTL ASTM D5397 Hours	Other
GEOMEMBRANE - FINAL COVER (POL 17269-1)	X	X	X	X	X	X	X	X				X EM ASTM 12 ASPERITY HEIGHT

NONWOVEN OR WOVEN GEOTEXTILE TESTING

SAMPLE ID	Thickness ASTM D5199 or D1777	Mass Per Area ASTM D5261 or D3776	Grab Tensile ASTM D4632	Trapezoid Tear ASTM D4533	Puncture Resistance ASTM D4833	Mullen Burst ASTM D3776	Permittivity ASTM D4491	AOS ASTM D4751	Wide Width Tensile ASTM D4596	UV (hrs) ASTM D4355	Other

GEOCOMPOSITE / GEONET / GEOGRID TESTING

SAMPLE ID	Thickness ASTM D5199 or D1777	Density ASTM D1505 or D792	Carbon Black Content ASTM D1603	Mass Per Area ASTM D5261 or D3776	Melt Flow Index ASTM D1238, cond. E	Peel ASTM D413, F904 or GRI-GC7	Transmissivity * ASTM D4716	Compression ASTM D1621	Tensile Strength ASTM D1682 or D5035	Wide Width Tensile ASTM D4596	Fib Tensile Strength GRI-GG1	Junction Strength GRI-GG2
GEOCOMPOSITE - FINAL COVER (POL 0403366)	X	X	X	X	X	X	X					

* Transmissivity Test Parameters: Normal Load: _____ Gradient: _____ Sealing Time: _____ Boundary Condition: _____

GCL TESTING

SAMPLE ID	Thickness ASTM D5199	Mass Per Area ASTM D5993	Grab Tensile ASTM D4632	Peel Strength ASTM D6196	Moisture Content ASTM D4643 or D2218	Hydraulic Conductivity ASTM D5084	Index Flux ASTM D5887	Swell Index ASTM D5890	Fluid Loss ASTM D5891	Internal Shear Strength ASTM D6245	Other	Other

SEND REPORT TO:

Name: MARTY CESURK
Company: FOTH & VAN DYKE
Address: 406 SCIENCE DR., MADISON, WI 53711
Phone: (608) 238-4761
Fax: (608) 238-4633
e-mail: unclesilk@foth.com

FIELD CONTACT:

Name: BRIAN STANUL
Page: N/A
Phone: (608) 576-1635
Fax: (608) 238-4761
e-mail: bstanul@foth.com

Released by:

Name: _____
Date/Time: 10/14/00

Shipped Via:

Fedex
 UPS
 Airborne
 DHL
 US Mail
 Others

Appendix F

Geomembrane Installation Forms

- F1 - Daily Geomembrane Installation Field Reports**
- F2 - Preproduction Weld Logs**
- F3 - Panel Placement Summary Forms**
- F4 - Panel Seaming Summary Forms**
- F5 - Non-Destructive Seam Test Summary Forms**
- F6 - Destructive Seam Sample Summary Forms**
- F7 - Repair Summary Forms**

Appendix F1
Daily Geomembrane Installation Field Reports

RESIDENT INSPECTION REPORT - SITE

Location: FINAL COVER

Weather	Temp.		Sky	Rain	Snow	Project Site	
	Lo	Hi					
	33	40	CLOUDY	TRACE	0	Dry	X Muddy

Contractors on Site:	Number of Men
<u>TERRA ENER. & CONST</u>	<u>1 - FOREMAN</u>
	<u>1 - OPERATOR</u>
	<u>3 - LABORERS</u>
<u>MIDESSA INDUSTRIAL VINYL Co.</u>	<u>4 - TECHNICIANS</u>
	<u>6 - LABORERS</u>

Other Personnel on Site:	Purpose
<u>RON MEISTER (FVD)</u>	<u>GEOMEMBRANE QC</u>
<u>KATHY GEYER (IEPA)</u>	<u>OBSERVE CAP INSTALLATION</u>

Report of Observation of Work and Comments: BJS1, MIDESSA, AND TERRA ON SITE AT 07:15. WARM, FOGGY, CLOUDY, VERY DAMP, 35°F. REM ON SITE AT 07:30. MIDESSA PREPARES TO DEPLOY GCL AND GEOMEMBRANE. MIDESSA DEPLOYED 3 ROLLS OF GCL AND 3 GEOMEMBRANE PANELS ON AFTERNOON OF 1/12. TERRA SEEDED TOPSOIL ON SEDIMENT BASINS, BERMS, AND WETLANDS, ~~BORROW~~ AND WETLAND BORROW AREA. MIDESSA BEGINS DEPLOYING GCL AT 08:10. KATHY GEYER (IEPA) ON SITE AT 09:00. MIDESSA BEGINS DEPLOYING GEOMEMBRANE AT 09:40. KATHY GEYER OFF SITE AT 10:30. MIDESSA PERFORMS TRIAL WELD AT 11:10. ADDITIONAL MIDESSA CREW ON SITE AT 11:15. MIDESSA STARTS WELDING GEOMEMBRANE SEAMS AT 11:55. LUNCH AT 13:45. MIDESSA RESUMES DEPLOYING GCL AND PREPARES TRIAL WELD AT 14:00. REM, TERRA OFF SITE AT 17:10. MIDESSA STOPS AT 17:30 AND CLEANS UP. BJS1 AND MIDESSA OFF SITE AT 18:00.

Additional Space on Back

Brian Starnel

Foth & Van Dyke

Client: MODERN PLATING CORP. Scope: R002027M015

Project: CAMU LANDFILL CONSTRUCTION Page: 1

Prepared by: BJSI Date: 1/14/01

RESIDENT INSPECTION REPORT - SITE

Location: FINAL COVER

Weather	Temp.		Sky	Rain	Snow	Project Site	
	Lo	Hi					
	35	40	CLOUDY	0.10"	TRACE	Dry	X Muddy

Contractors on Site: TERRA ENGR. & CONST. Number of Men
~~1 - OPERATOR~~

MIDESSA INDUSTRIAL VINYL Co. 4 - TECHNICIANS
6 - LABORERS

Other Personnel on Site: RON MEISTER (FVD) Purpose
GEOMEMBRANE QC
KATHY GEYER (IEPA) OBSERVE CAP INSTALLATION

Report of Observation of Work and Comments: BJSI AND TERRA ON SITE AT 07:00.
DRIZZLE AND LIGHT RAIN, 35°F. MIDESSA ON SITE AT 07:40, REM ON
SITE AT 07:45. SNOWING AT 08:10. MIDESSA DEPLOYS GCL AND PREPARES
TO PATCH REPAIRS AT 08:40. KATHY GEYER (IEPA) ON SITE AT 09:15.
MIDESSA BEGINS DEPLOYING GEOMEMBRANE AT 09:30. MIDESSA BUILDS
SHELTER FOR WELDING AT 10:00. KATHY GEYER OFF SITE AT 10:45. MIDESSA
PERFORMS TRIAL WELD AT 12:00 AND HAS DIFFICULTIES DUE TO WET
CONDITIONS. LUNCH AT 12:30, REM OFF SITE, MIDESSA RESUMES
DEPLOYING GCL AND PERFORMS TRIAL WELD AT 13:30, MIDESSA
BEGINS SEAMING GEOMEMBRANE AT 14:20. MIDESSA TESTS COUPONS FROM
EACH SEAM FOR PEEL AND SHEAR. RAINING AT 17:15. MIDESSA USES
SHELTER OVER WELDER, MIDESSA STOPS AT 17:20. BJSI, MIDESSA,
AND TERRA OFF SITE AT 18:00.

Additional Space on Back

Brian Stamm

Foth & Van Dyke

Client: MODERN PLATING CORP. Scope: R002025M015
Project: CAMU LANDFILL CONSTRUCTION Page: 1
Prepared by: BJSI Date: 1/15/01

RESIDENT INSPECTION REPORT - SITE

Location: FINAL COVER

Weather	Temp.		Sky	Rain	Snow	Project Site	
	Lo	Hi					
	25	35	CLOUDY	0	0	Dry	X Muddy

		Number of Men
Contractors on Site:	<u>TERRA ENGR. & CONST.</u>	<u>1-FOREMAN</u>
		<u>1-OPERATOR</u>
		<u>2-LABORERS</u>
	<u>MIDESSA INDUSTRIAL VINYL CO.</u>	<u>4-TECHNICIANS</u>
		<u>5-LABORERS</u>

		Purpose
Other Personnel on Site:	<u>SECRET STROBL (FVD)</u>	<u>GEOMEMBRANE QC</u>
	<u>KATHY GEYER (IEPA)</u>	<u>OBSERVE CAP INSTALLATION</u>
	<u>SCOTT ZIMMERMAN (TERRA)</u>	<u>SITE VISIT, OBSERVE WORK PROGRESS</u>
	<u>MARTY CIESLIK (FVD)</u>	<u>OBSERVE CAP INSTALLATION</u>

Report of Observation of Work and Comments:

BJSI, TERRA ON SITE AT 07:00. STS, MIDESSA ON SITE AT 07:30. MIDESSA PREPARES TO WELD SEAMS AND REPAIRS ON GEOMEMBRANE. MIDESSA FIELD TESTS DESTRUCTIVE SAMPLES DT-1, DT-2, & DT-3 AT 08:00. DT-1 HAD SEVERAL PEEL FAILURES. KATHY GEYER ON SITE AT 08:50. MIDESSA PERFORMS TRIAL WELD AT 09:05. SCOTT ZIMMERMAN ON SITE AT 09:30. MARTY CIESLIK ON SITE AT 10:10. MIDESSA COLLECT SEAM SAMPLES FROM BEFORE AND AFTER DT-1 TO ISOLATE BAD SEAM AT 10:30. LUNCH AT 13:30. MIDESSA RESUMES WORK AT 14:15. MIDESSA VACUUM BOX TESTS PATCHES AT 15:00. MIDESSA HAS ISOLATED THE BAD SEAMS BEFORE AND AFTER DT-1. TWO MORE DESTRUCTIVE SAMPLES, DT-1B & DT-1A COLLECTED AT 15:30 AND PASS FIELD TESTS. MIDESSA EXTRUSION WELDS SEAMS FROM DT-1B TO DT-1A. BJSI TO FED EX IN ROCKFORD WITH DESTRUCTIVE SAMPLES DT-1, DT-1A, DT-1B, DT-2, DT-3, DT-4, DT-5 (FUSION WELDS), AND DT-6 (EXTRUSION WELD OF REPAIRED SEAM) AT 16:15. BJSI BACK ON SITE AT 17:15. MIDESSA STOPS AT 17:30.

Additional Space on Back

Brian Stamm

RESIDENT INSPECTION REPORT - SITE

Location: FINAL COVER

Weather	Temp.		Sky	Rain	Snow	Project Site	
	Lo	Hi					
	25	35	CLOUDY	0	0	X Dry	Muddy

Contractors on Site:	Number of Men
<u>TERRA ENER. & CONST.</u>	<u>1-FOREMAN</u>
	<u>1-OPERATOR</u>
	<u>2-LABORERS</u>
<u>MIDESSA INDUSTRIAL VINYL CO.</u>	<u>4-TECHNICIANS</u>
	<u>6-LABORERS</u>

Other Personnel on Site:	Purpose
<u>SECRET STROBL (FVD)</u>	<u>GEOMEMBRANE QC</u>
<u>JIM LOGAN (FVD)</u>	<u>GEOMEMBRANE SURVEY</u>
<u>KATHY GEYER (TERPA)</u>	<u>OBSERVE CAP INSTALLATION</u>

Report of Observation of Work and Comments: BJSI, STS, AND TERRA ON SITE AT 07:00. MIDESSA ON SITE AT 07:40. MIDESSA VACUUM BOX TESTS PATCHES AND SEAMS AT 08:00. MIDESSA PERFORMS TRIAL WELDS AT 08:30. JIM LOGAN ON SITE AT 08:40. MIDESSA RESUMES EXTRUSION WELDING PATCHES. MIDESSA BEGINS AIR CHANNEL TESTING AT 10:00. KATHY GEYER ON SITE. KATHY GEYER OFF SITE AT 11:00. MIDESSA BEGINS DEPLOYING GEOCOMPOSITE ON WEST END OF CAP AT 11:15. JIM LOGAN OFF SITE AT 11:30. SURVEY OF GEOMEMBRANE COMPLETED. LUNCH AT 12:15. MIDESSA RESUMES DEPLOYING GEOCOMPOSITE, AIR CHANNEL TESTING, AND VACUUM BOX TESTING AT 13:15. BJSI RECEIVES DESTRUCTIVE SAMPLE RESULTS FROM MJC1 AT 13:30. DT-4 FAILED. MIDESSA COLLECTS AND TESTS SEAM SAMPLES FROM 25' ON EACH SIDE OF DT-4. FIELD TEST RESULTS PASS AT 14:00. MIDESSA CUTS DT-4B AND DT-4A FROM TEST LOCATIONS TO SUBMIT TO LAB AT 14:15. BJSI TO FEDEX IN ROCKFORD WITH DESTRUCTIVE SAMPLES AT 15:00. BJSI BACK ON SITE AT 16:15. MIDESSA STOPS SEAM TESTING AT 16:45. MIDESSA STOPS PLACING GEOCOMPOSITE AT 17:00. BJSI OFF SITE AT 17:30.

Additional Space on Back

Brian Starnel

Foth & Van Dyke

Client: MODERN PLATING CORP. Scope I.D.: R002027 07/15/01
Project: CAMU LANDFILL CONSTRUCTION Page: 1
Prepared by: BJSI Date: 1/17/01

RESIDENT INSPECTION REPORT - SITE

Location: FINAL COVER

Weather	Temp.		Sky	Rain	Snow	Project Site	
	Lo	Hi					
	10	32	PARTLY CLOUDY	0	0	X Dry	Muddy

Contractors on Site: TERRA ENGR. & CONST. Number of Men
1-FOREMAN
1-OPERATOR
2-LABORERS
MIDESSA INDUSTRIAL VINYL CO. 4-TECHNICIANS
6-LABORERS

Other Personnel on Site: SECRET STROBL (FVD) Purpose
KATHY GEYER (IEPA) GEOMEMBRANE QC
OBSERVE CAP INSTALLATION

Report of Observation of Work and Comments: BJSI ON SITE AT 07:00. TERRA FILLS ANCHOR TRENCH ON WEST END WITH STONE, MIDESSA ON SITE. STS ON SITE AT 07:30. MIDESSA WORKS ON GEOCOMPOSITE AND VACUUM BOX TESTS PATCHES. MIDESSA PERFORMS TRIAL WELD AT 08:35. MIDESSA INSTALLS PIPE BOOTS AROUND PHASE I & 2 LEACHATE/LEAK DETECTION PIPES AT 09:00. KATHY GEYER ON SITE AT 10:50, BJSI RECEIVES VERBAL FROM MJCL THAT DT-4B & 4A PASS. O.K TO COVER CAP AT 11:30. MIDESSA EXTRUSION WELDS SEAM BETWEEN DT-4B AND DT-4A AT 12:00. LUNCH AT 12:15. KATHY GEYER OFF SITE. MIDESSA RESUMES DEPLOYING GEOCOMPOSITE AND SEAM AND PATCH TESTING AT 13:15. STS PERFORMS QC, BJSI PACKS GCL CONFORMANCE SAMPLES FOR SHIPPING, BJSI TO FEDEX IN ROCKFORD WITH GCL SAMPLES AT 15:30. BJSI BACK ON SITE AT 16:45. GEOMEMBRANE TESTING COMPLETED, MIDESSA COMPLETES GEOCOMPOSITE INSTALLATION AT 17:15 AND PACKS UP. STS OFF SITE AT 17:30. MIDESSA, BJSI, AND TERRA OFF SITE AT 18:45.

Additional Space on Back

Brian Stornal

Appendix F2

Preproduction Weld Logs

TRIAL WELD SUMMARY

TW -

Project Name: MODERN PLATING - FINAL COVER Page of

Project No: 97M015 Date: 1/14/01 Computer Entry By:

Installer: MIDESSA Checked By:

Test No.	Time	QA Monitor	Weather		Welder ID	Mach. No.	Extrusion Welds		Fusion Welds		PEEL (PPI)			SHEAR (PPI) 1	Pass/Fail	Comments
			(Wind/Precip.)	(Wind/Precip.)			Barrel Temp.	Preheat Temp.	Wedge Temp.	Speed Setting	Inside/Outside Weld					
											1	2	3			
1	12:10	BSS1	5	DRIZZLE	RV	5	-	-	836	11	105/95	131/32			F	
2	12:20	PSS1	5	DRIZZLE	F /	5	.	.	836	11	134/32				F	
3	13:50	PSS1	5	LT RAIN	RV	6	-	-	850	9	136/19	143/26	91/98	185	F	

6

R002030

TRIAL WELD SUMMARY

TW -

Project Name: MODERN PLATING - FINAL COVER

Page of

Project No: 97M015

Date: 1/15/01

Computer Entry By:

Installer: MIDESSA

Checked By:

Test No.	Time	QA Monitor	Weather		Welder ID	Mach. No.	Extrusion Welds		Fusion Welds		PEEL (PPI)			SHEAR (PPI) 1	Pass/Fail	Comments			
			(Wind/Precip.)	(Wind/Precip.)			Barrel Temp.	Preheat Temp.	Wedge Temp.	Speed Setting	Inside/Outside Weld								
			1	2							3								
1	09:10	BSS1	10	0	RV	6	-	-	830	11	133	88			F	TEX/TEX			
2	09:25	BSS1	10	0	RV	6	-	-	840	9	112				F				
3	09:30	BSS1	10	0	RV	249	500	450	-	-	92	87	99	170	P	TEX/TEX			
4	09:45	BSS1	10	0	RV	5	-	-	840	11	129	139	124			F			
5	09:55	BSS1	10	0	RV	5	-	-	850	10	134	155	146	130	141	131	183	P	TEX/TEX
6	10:00	BSS1	10	0	GG	9	500	450	-	-	117	118	113	165	P	TEX/TEX			
7	10:10	BSS1	10	0	FA	8	500	450	-	-	90	107	97	118	168	P			

10

R002031

TRIAL WELD SUMMARY

TW -

Project Name: MODERN PLATING - FINAL COVER

Page of

Project No: 97M015

Date: 1/17/01

Computer Entry By:

Installer: MIDESSA

Checked By:

Test No.	Time	QA Monitor	Weather		Welder ID	Mach. No.	Extrusion Welds		Fusion Welds		PEEL (PPI)			SHEAR (PPI) 1	Pass\Fail	Comments			
			(Wind/Precip.)	(Wind/Precip.)			Barrel Temp.	Preheat Temp.	Wedge Temp.	Speed Setting	Inside\Outside Weld								
			1	2							3								
1	08:35	BJS1	5	0	GG	9	500	450	—	—	125	—	146	—	143	—	182	P	

12

R002033

Appendix F3

Panel Placement Summary Forms

PANEL PLACEMENT SUMMARY

PP -

Project Name: **MODERN PLATING - FINAL COVER**

Page of

Project No: **9.7MO15**

Date: **1/13/01**

Computer Entry By:

Installer: **MIDESSA**

Checked By:

Panel Number	Roll Number/ Material Type	Panel Location	Time Deployed	Weather		QA Monitor	Panel Damage (y/n)	Subgrade Conditions	Length/ Width (feet)	Comments
				Temp./Wind/ Precip.						
P-3	17269-1/40-mil HDPE	FINAL COVER	09:45	38°F/5/0	BJSI	N	OK	154/22		
P-4	↓ /	↓	11:45	35°F/10/0	↓	↓	↓	79/1		
P-5	↓ /	↓	11:50	40°F/10/0	↓	↓	↓	87/1		
P-6	↓ /	↓	11:55	↓	↓	↓	↓	154/1		
P-7	17267-1/	↓	12:50	↓	↓	↓	↓	133/1		
P-8	↓ /	↓	15:00	38°F/10/0	↓	↓	↓	149/1		
P-9	↓ /	↓	15:30	↓	↓	↓	↓	154/1		
P-10	↓ /	↓	16:25	35°F/16/0	↓	↓	↓	155/1		
P-11	↓ / ↓	↓	16:55	↓	↓	↓	↓	178/↓		
P-12	17268-1/	↓	17:15	35°F/5/0	↓	↓	↓	58/3		
P-13	↓ / ↓	↓	17:15	↓	↓	↓	↓	59/3		

15

R002036

PANEL PLACEMENT SUMMARY

PP -

3/100
1/2

Project Name: MODERN PLATING - FINAL COVER Page _____ of _____

Project No: 97M015 Date: 1/14/01 Computer Entry By: _____

Installer: WIDESSA Checked By: _____

Panel Number	Roll Number/ Material Type	Panel Location	Time Deployed	Weather	QA Monitor	Panel Damage (y/n)	Subgrade Conditions	Length/ Width (feet)	Comments
				Temp./Wind/ Precip.					
P-14	17268-1/ 40mil HDPE	FINAL COVER	10:05	33°F/5/SNOW	BJSI	N	WET	194/22	
P-15	↓ / ↓	↓	11:15	35°F/5/DRIEST	↓	↓	↓	194/22	
P-16	↓ / ↓	↓	14:15	35°F/5/LT. RAIN	↓	↓	↓	113/22	
P-17	17271-1/	↓	14:55	↓	↓	↓	↓	89/1	
P-18	17268-1/	↓	15:00	↓	↓	↓	↓	204/	
P-19	17271-1/	↓	15:55	↓	↓	↓	↓	204/√	
P-20	17268-1/	↓	16:00	↓	↓	↓	↓	44/7	
P-21	17271-1/	↓	16:10	↓	↓	↓	↓	56/7	
P-22	↓ / ↓	↓	16:15	↓	↓	↓	↓	56/7	
P-23	↓ / ↓	↓	16:15	↓	↓	↓	↓	56/7	

16

R002037

Appendix F4

Panel Seaming Summary Forms

PANEL SEAMING SUMMARY

PS -

Project Name: <u>MODERN PLATING - FINAL COVER</u>	Page of
Project No: <u>97M015</u>	Date: <u>1/13/01</u>
Installer: <u>MIDESSA</u>	Computer Entry By: _____ Checked By: _____

Seam Number	QA Monitor	Weather Conditions			Seam Length (feet)	Welder Initials	Weld Type	Machine Number	Temp. Setting	Speed Setting	Time		Comments
		Ambient Temp.	Sheet Temp. (if req.)	Wind/Precip.							Start	End	
P1/P2	BJS1	^{40.6} 35°F		10/0	154	RV	F	5	865	500	11:57	12:12	
P2/P3	REM	^{40.6} 35°F		10/0	154	RV	F	5	865	500	12:17	12:29	
P3/P6	BJS1	^{40.6} 35°F	49.2	10/0	154	RV	F	5	865	500	12:42	12:51	
P4/P5	↓	38.1			79	↓	↓	↓	↓	↓	13:09	13:16	
P5/P7	↓	40.1			87	↓	↓	↓	↓	↓	13:20	13:26	
P6/P8	BJS1	36.3	36.3	10/0	149	RV	F	5	865	500	15:17	15:29	
P1/P9	↓	35			154	↓	↓	↓	↓	↓	16:01	16:18	
P9/P10	↓				155	↓	↓	↓	↓	↓	16:32	16:48	
P10/P11	↓				155	↓	↓	↓	↓	↓	17:00	17:17	
P12/P13	↓				3	↓	↓	↓	↓	↓	17:23	17:25	

DT-1
DT-2

462
166
628
777
931
1086
1241

R002039

PANEL SEAMING SUMMARY

PS -

Project Name: **MODERN PLATING - FINAL COVER**

Page **1** of **1**

Project No: **97MOIS**

Date: **1/14/01**

Computer Entry By:

Installer: **MIDESSA**

Checked By:

Seam Number	QA Monitor	Weather Conditions			Seam Length (feet)	Welder Initials	Weld Type	Machine Number	Temp. Setting	Speed Setting	Time		Comments
		Ambient Temp.	Sheet Temp. (if req.)	Wind/Precip.							Start	End	
P11/P14	BJS1	35°F		5/RAIN	178	RV	F	6	850	9	14:19	14:47	
P14/P15	↓	↓	36.8	↓	194	↓	↓	↓	↓	↓	16:09	16:32	
P16/P17	↓	↓		↓	22	↓	↓	↓	↓	↓	16:46	16:49	
P15/P17	↓	↓		↓	89	↓	↓	↓	↓	↓	16:55	17:06	
P15/P16	↓	↓		↓	113	↓	↓	↓	↓	↓	17:06	17:20	

19

121
1219
194
1513
22
89
113

1737

R002040

PANEL SEAMING SUMMARY

PS -

Project Name: MODERN PLATING - FINAL COVER							Page of		
Project No: 97M015				Date: 1/15/01			Computer Entry By:		
Installer: MIDESSA							Checked By:		

Seam Number	QA Monitor	Weather Conditions			Seam Length (feet)	Welder Initials	Weld Type	Machine Number	Temp. Setting	Speed Setting	Time		Comments
		Ambient Temp.	Sheet Temp. (if req.)	Wind/Precip.							Start	End	
P16/P18	BJS1	35°F		10/0	113	RV	F	5	850	10	09:59	10:07	
P17/P18					89						10:07	10:17	
P18/P20					44						11:10 10:40	11:13 10:43	
P18/P21					56						11:13 10:43	11:19	
P20/P21					7						10:30	10:33	
P21/P22					7						10:34	10:37	
P22/P23					7						10:37	10:40	
P18/P22					56						11:19	11:26	
P18/P23					56						11:26	11:33	
P19/P20					44						11:45	11:58	
P19/P21					56						11:58	12:04	
P19/P22					56						12:04	12:08	
P19/P23					56						12:08	12:14	
P7/P12					58						12:32	12:35	
P7/P13					59						12:35	12:40	
P8/P12					58						12:43	12:48	
P8/P13					59						12:50	12:56	
P7/P8	↓	↓		↓	37	↓	↓	↓	↓	↓	13:02	13:06	

20

1737
113
1846
82
1920
11
1973
56
2029

21
2050

2384

R002041
265

PANEL SEAMING SUMMARY

PS -

Project Name: Modern Plating Final Cover Page 1 of
 Project No: 92m015 Date: 1/15/01 Computer Entry By:
 Installer: Midessa "Columbine" Checked By:

Seam Number	QA Monitor	Weather Conditions			Seam Length (feet)	Welder Initials B.V.	Weld Type	Machine Number	Temp. Setting	Speed Setting	Time		Comments
		Ambient Temp.	Sheet Temp. (if req.)	Wind/Precip. It. snow							Start	End	
P4/P5	STS	38°F		10-15 mph 5 west		G.G.	Ext. #8	X2-SC	500°F	Manual	1145	1215	*Note: Extrusion Weld
P5/P7	↓	35°F		10-15 mph		↓	↓	Leister	#LEI	8398	1240	1330 1430 1445	Break Resume Seams due to DT-1 failure.
P8/P6	↓	30°F		10-15		↓	↓				1500		↓
P6/P3	↓	30°F		10-15		↓	↓				1600		↓

21

R002042

Appendix F5

Non-Destructive Seam Test Summary Forms

NON-DESTRUCTIVE SEAM TEST SUMMARY

ND -

Project Name: Modern Plating Final Corev

Page _____ of _____

Project No: 97mp15

Date: 1/15/01

Computer Entry By:

Installer: Midessa

Checked By:

Seam Number	Interval Tested	QA Monitor	Tester Initials	Air Test				X Vacuum Test			AGV6100 Robin 2.5 Shop Vac Comments Vacuum 2 1/2 psi	
				Air Pressure Test				Air Test Results (P/F)	Date Vacuum Tested	Vac. Test Results (P/F)		
				Start		End						Drop (PSI)
				PSI	Time	PSI	Time					
P-4/P-5		STS	RRB									
5/7												
Repairs (#1-15)												
P-6/8												
P-6/3												
Repairs (#15-23)												
Gas Vent												
End of Day												

23

R002044

NON-DESTRUCTIVE SEAM TEST SUMMARY

ND -

Project Name: MODERN PLATING - FINAL COVER Page of

Project No: 97MOIS Date: 1/16/01 Computer Entry By:

Installer: WIDESSA Checked By:

Seam Number	Interval Tested	QA Monitor	Tester Initials	Air Test					Vacuum Test			Comments
				Air Pressure Test				Drop (PSI)	Air Test Results (P/F)	Date Vacuum Tested	Vac. Test Results (P/F)	
				Start		End						
				PSI	Time	PSI	Time					
✓ P7/P3	P58-P22	BSSI	PV	32	10:20	32	10:25	0	P			
✓ P1/P2	P23-ENI			30	10:23	30	10:26	0	P			
✓ P1/P2	R24-R25			31	10:08	30	10:13	1	P			
✓ P1/P2	P-25-ENI			32	10:25	32	10:30	0	P			
P1/P9	R26-END			34	10:33	30	10:38	4	P			
P1/P9	R26-P27		↓	35	10:33	35	10:38	0	P			
24 P1/P9	R27-P28		GG	34	10:33	30	10:38	4	P			
P1/P9	R28-END			35	10:32	33	10:37	2	P			
P11/P14	R37-END			30	10:54	28	10:59	2	P			
P11/P14	R37-P36			32	10:54	28	10:59	4	P			
P9/P10	P30-R32			31	10:58	31	11:03	0	P			
P9/P10	R30-ENI			34	10:58	32	11:03	2	P			
P7/P8	R11-END			34	11:03	30	11:08	4	P			
P8/P12	R60-END		↓	31	11:40	30	11:45	1	P			
P8/P12	R20-ENI		RV							1/16/01	P	
P7/P12	END-END		GG	35	11:35	35	11:40	0	P			
P7/P13	END-END		RV							1/16/01	P	
P14/P15	R38-R39		GG	34	11:51	34	11:56	0	P			
✓ P2/P3	R21-R59		GG	35	11:56	33	12:01	2	P			
✓ P2/P3	R59-R20		↓	RV						1/16/01	P	

R002045

NON-DESTRUCTIVE SEAM TEST SUMMARY

ND -

Project Name: MODERN PLATING - FINAL COVER										Page of		
Project No: 97MO15					Date: 1/16/01					Computer Entry By:		
Installer: MIDESSA										Checked By:		
Seam Number	Interval Tested	QA Monitor	Tester Initials	Air Test					Vacuum Test			Comments
				Air Pressure Test					Air Test Results (P/F)	Date Vacuum Tested	Vac. Test Results (P/F)	
				Start		End		Drop (PSI)				
				PSI	Time	PSI	Time					
P11/P14	R36-END	BJS1	GG	34	12:07	31	12:12	3	P	1/16/01	P	
P14/P15	R39-END	↓	↓	35	12:07	33	12:12	2	P			
P14/P15	R37-R38	↓	↓	35	13:15	33	13:20	2	P			
P15/P17	R42-END	STS	↓	35	1441	33	1446	2	P			
P22/19	R49-End	↓	↓	35	1413	35	1418	0	P			
P22/19	R49-R50	↓	↓	32	1407	31	1412	1	P			
P21/18	R45-R44	↓	↓	31	1350	30	1355	1	P			
P21/19	R50-52	↓	↓	35	1406	35	1411	0	P			
P22/19	R52-End	↓	↓	32	1406	32	1411	0	P			
P18/20	R44-End	↓	↓	34	1354	34	1359	0	P			
P18/21/22	R45-End	↓	↓	35	1351	33	1356	2	P			
P10/11	END- END END	↓	↓	35	1423	34	1428	1	P			
P18/17	END-END Tce	↓	↓	36	1536	35	1541	1	P			
P18/22	R61-64	↓	↓	35	1600	34	1605	1	P			
P17/18	Tce-End	↓	↓	35	1605	35	1610	0	P			
P16/18	END-END	↓	RV							1/16/01	1/17/01	Half of seam each day
P11/P14	R35-END	↓	↓							↓	P	

25

R002046

NON-DESTRUCTIVE SEAM TEST SUMMARY

ND -

Project Name: **MODERN PLATING - FINAL COVER** Page **1** of **3**
 Project No: **97MO15** Date: **1/16/01** Computer Entry By:
 Installer: **WIDESSA** Checked By:

Vacuum Seam Number of Repairs	Test Interval Tested	QA Monitor	Tester Initials	Air Test					Vacuum Test			Vacuum Test of Repairs Air = 400°F Comments T = 500°F	
				Air Pressure Test					Air Test Results (P/F)	Date Vacuum Tested	Vac. Test Results (P/F)		
				Start		End		Drop (PSI)					
				PSI	Time	PSI	Time						
P1/P2-	R-23	STS	RRV							1/16/01	P		
P1/2	R-24	↓	↓										
P1/2	R-25	↓	↓										
P1/9	R-26	↓	↓										
P1/9	R-27	↓	↓										
P1/9	R-28	↓	↓									DT-1A	
P-1	R-29	↓	↓										
P9/10	R-30	↓	↓									DT-2	
P-10	R-31	↓	↓									Gas Vent Pipe	
P-9	R-32	↓	↓										
P-10	R-33	Not Tested Since pipe boots were not fabricated as of 1/16/01, 1300											
P.10/11	R-34	" " " " " " " " " " " "											Pipe boots fabricated 1/17/01
P11/P14	R-35	STS	RRV							1/16/01	P	1 leak & repaired (see pg.3)	
P11/14	R-36	↓	↓										
P11/14	R-37	↓	↓										
P14/15	R-38	↓	↓										
P14/15	R-39	↓	↓									1 leak & repaired	
P11/14	15 ft of north seam to anchor trench												
P16	R-40	↓	↓									Gas Vent	
P17	R-41	↓	↓									Gas Vent	
P15/17	R-42	↓	↓									1 leak & repaired	

26

R002047

NON-DESTRUCTIVE SEAM TEST SUMMARY

ND -

Project Name: **MODERN PLATING - FINAL COVER**

Page **2** of **3**

Project No: **97MO15**

Date: **1/16/01, 1/17/01**

Computer Entry By:

Installer: **MIDESSA**

Checked By:

Vacuum Test Seam Number	Interval Tested	QA Monitor	Tester Initials	Air Test					Vacuum Test			Comments
				Air Pressure Test					Air Test Results (P/F)	Date Vacuum Tested	Vac. Test Results (P/F)	
				Start		End		Drop (PSI)				
				PSI	Time	PSI	Time					
P15/17	R-43	STS	RRV						1/16/01	P		
P22/18	R-64								↓	↓	DT 4A	
P21/18	R-65								↓	↓	DT 4B	
P21/18	R-66								↓	↓		
P18/21/20	R-44								1/17/01	P		
P18/21	R-45											
P18/2/22	R-46											
P18/23	R-47											
P18/23	R-48											
P19/23	R-49										DT-5	
P18/2/22	R-50											
P21	R-51											
P19/20/21	R-52											
P19/20	R-53											
P19	R-54								↓	↓	SE corner	
P19	R-55								1/16/01	P		
P2/3	R-56											
P2/3	R-57											
P2/3	R-58								↓	↓	Note: tester scraped ice off vacuum box gasket multiple times	
P2/3	R-59											
P8/12	R-60								1/16/01	↓		

27

P13/22/23 R-61, R-62, R-63, P14/22/23 P16/18 (R-61-R-67), R-60 tested 1/17/01

R002048

Appendix F6
Destructive Seam Sample Summary Forms

DESTRUCTIVE SAMPLE SUMMARY

DS -

Project Name: MODERN PLATING - FINAL COVER										Page of			
Project No: 97M015					Date: 1/15/01 - 1/16/01					Computer Entry By:			
Installer: MIDESSA					Computer Entry By:					Checked By:			
Destr. Sample Number	QA Monitor	Seam Number	Machine Number	Welder Initials	Location Description	Field Tensiometer Test Results (lbs./inch)					Date Sent to Lab	Lab Results (P/F)	Comments
						128	127	132	121	133			
DT-1	BJS1	P4/P5	5	RV		128	127	132	121		1/15/01	F	PEEL FAILURES
DT-2	BJS1	P9/P10	5	RV		132	119	130	134	121	1/15/01	P	
DT-3	BJS1	P14/P15	6	RV		131	130	131	106	130	1/15/01	P	1 PEEL FAILURE
DT-4	BJS1	P19/P21	5	RV		131	129	128	116	102	1/15/01	F	
DT-5	BJS1	P19/P23	5	RV		132	143	113	145	139	1/15/01	P	
DT-1A	BJS1	P1/P9	5	RV		123	124	122	123	127	1/15/01	P	RETEST OF SEAM AFTER DT-1
DT-1B	BJS1	P2/P3	5	RV							1/15/01	P	RETEST OF SEAM BEFORE DT-1
DT-6	BJS1	P6/P8	9	GG							1/15/01	P	EXTENSION WELD OF REPAIRED SEAM
DT-4B	BJS1	P18/P21	5	RV							1/16/01	P	RETEST 25' NORTH OF DT-4
DT-4A	BJS1	P18/P21	5	RV							1/16/01	P	RETEST 25' SOUTH OF DT-4

30

R002051

Appendix F7

Repair Summary Forms

LINER REPAIR SUMMARY

LR -

Project Name: MODERN PLATING CORP. - FINAL COVER		Page 1 of 4	
Project No: 97M015		Date: 1/15/01, 1/16/01	
Installer: MIDESSA		Computer Entry By:	
		Checked By:	

Repair Number	QA Monitor	Oper./Mach	Repair Location (Seam I.D., Panel I.D. or Coordinates)	Damage Description/Comments on Repair	Type and Size of Repair	Date Vacuum Tested	Tester's Initials	Vac. Test Results (P/F)
R-1	STS	GG/9	P4/P5	Patch, DT-1 (midpoint)	2'x5'	1/15/01	RV	P
R-2	↓	↓	P5/P7	Patch (south near anchor)	1'x1.5'	↓	↓	↓
R-3	↓	↓	P5/P7	Patch (south near anchor)	1'φ	↓	↓	↓
End of Day 1/15/01								
Start of Day 1/16/01								
R-4	STS	GG/9	P5/P7	Patch (midpoint)	2'φ	1/16/01	RV	P
R-5	↓	↓	P5/P7	Patch (north near anchor)	1'φ	↓	↓	↓
R-6	↓	↓	P4/P5	Bead	6"	↓	↓	↓
R-7	↓	↓	P7 (north)	Patch (north near anchor)	1'φ	↓	↓	↓
R-8	↓	↓	P7 (north)	Patch (north slope)	1'φ	↓	↓	↓
R-9	↓	↓	P7 (north)	Patch (north slope)	1'φ	↓	↓	↓
R-10	↓	↓	P7 (north)	Patch (midpoint)	1'φ	↓	↓	↓
R-11	↓	↓	P7/P8/P13	Patch (seams meet)	1'φ	↓	↓	↓
R-12	↓	↓	P7/P8/P13	Patch (east of seams)	1.5'φ	↓	↓	↓
R-13	↓	↓	P7	Patch (north slope)	1'φ	↓	↓	↓
R-14	↓	↓	P6/P8	Patch, DT-6 (midpoint)	2'x4'	↓	↓	↓
R-15	↓	↓	P6/P3	Patch (midpoint)	1'φ	↓	↓	↓
R-16	↓	↓	P6/P3	Patch (north slope)	2'φ	↓	↓	↓
R-17	↓	↓	P3/P2	Patch (north near anchor)	2'φ	↓	↓	↓
R-18	↓	↓	P3/P2	Patch (north near anchor)	1'x2'	↓	↓	↓
R-19	↓	↓	P3/P2	Patch (north slope)	1'φ	↓	↓	↓
R-20	↓	↓	P3/P2	Patch (north slope)	1.5'x1'	↓	↓	↓

32

R002053

LINER REPAIR SUMMARY

LR -

Project Name: **MODERN PLATING - FINAL COVER**

Page **3** of **4**

Project No: **97M015**

Date: **1/16/01**

Computer Entry By:

Installer: **MIDESSA**

Checked By:

Repair Number	QA Monitor	Oper./ Mach	Repair Location (Seam I.D., Panel I.D. or Coordinates)	Damage Description/Comments on Repair	Type and Size of Repair	Date Vacuum Tested	Tester's Initials	Vac. Test Results (P/F)
R-31	BSSZ	GG/9	P10	GAS VENT PIPE	4'x4'	1/16/01	RV	P
R-32			P9/P10	PATCH	1.5'φ	↓	↓	P
R-33			P10	PHASE 1 PIPE BOOT	5'x3'	1/17/01	RV	P
R-34			P10/P11	PHASE 2 PIPE BOOT	5'x3'	1/17/01	↓	P
R-35			P11/P14	PATCH	1.5'φ	1/16/01	RV	P
R-36			P11/P14	↓	1'φ			
R-37			P11/P14	↓	3'x2'			
R-38			P14/P15	↓	1.5'φ			
R-39			P14/P15	PATCH / DT-3	4'x2'			
R-40			P16	GAS VENT PIPE BOOT	4'x4'			
R-41			P17	GAS VENT PIPE BOOT	4'x4'			
R-42			P15/P17	PATCH	1'φ			
R-43			P15/P17	↓	1.5'φ			
R-44			P18/P20/P21	TEE	6"			
R-45			P18/P21	PATCH / DT-4	4'x2'			
R-46			P18/P21/P22	TEE	6"			
R-47			P18/P23	BEAD	1.5'φ			
R-48			P18/P23	↓	1.5'			
R-49			P19/P23	PATCH / DT-5	4'x2'			
R-50			P19/P21/P22	TEE	6"			
R-51			P21	PATCH	1'φ			
R-52	↓	↓	P19/P20/P21	TEE	6"	↓	↓	↓

34

R002055

LINER REPAIR SUMMARY

LR -

Page 4 of 4

Project Name: MODERN PLATING - FINAL COVER

Project No: 97M015

Date: 1/16/01

Computer Entry By:

Installer: MIDESSA

Checked By:

Repair Number	QA Monitor	Oper./ Mach	Repair Location (Seam I.D., Panel I.D. or Coordinates)	Damage Description/Comments on Repair	Type and Size of Repair	Date Vacuum Tested	Tester's Initials	Vac. Test Results (P/F)
R-53	BJS1	GG/9	P19/P20	PATCH	1.5'x2'	1/16/01	RV	P
R-54	↓	↓	P19	PATCH	2'x3'			
R-55	↓	↓	P1/P9	PATCH	1.5'x2'			
R-56	↓	↓	P2/P3	BEAD	6"			
R-57	↓	↓	P2/P3	↓	6"			
R-58	↓	↓	P2/P3	↓	6"			
R-59	STS	GG/9	P2/P3	Bead	6"			
R-60	↓	↓	P12/P8	Bead (south slope)	4"			
R-61	↓	↓	P22/P23	Bead Tee (west)	4"			
R-62	↓	↓	P22/P23	Tee (east)	4"			
R-63	↓	↓	P16/P18	Bead (midpoint)	6"			
R-64	↓	↓	P18/P22	Patch - DT4A	2'x3'			
R-65	↓	↓	P21/18	Patch - DT4A DT4B	1.5'x3'			
R-66	↓	↓	P21/18	Patch - DT4B	1'x2'			
R-67	STS	GG/9	P17/18	Bead	6"	↓	↓	↓

35

R002056

LINER REPAIR SUMMARY

LR -

Project Name: MODERN PLATING - FINAL COVER Page 1 of 1

Project No: 97M015 Date: 1/17/01 Computer Entry By:

Installer: WIDESSA Checked By:

Repair Number	QA Monitor	Oper./Mach	Repair Location (Seam I.D., Panel I.D. or Coordinates)	Damage Description/Comments on Repair	Type and Size of Repair	Date Vacuum Tested	Tester's Initials	Vac. Test Results (P/F)
R-68	SIS	RV/6	P-11	Patch (south near anchor)	1' Ø	1/17/01	RV	P
R-69	"	"	P-18/P21/P22	Bead, repair from R-65 (DT-1B) to R-64 (DT-1A)	29'	"	"	"
R-33	↓	↓	P-10	Pipe Boot (west)	3'x5'	1/17/01	RV	P
R-34	↓	↓	P-10/P-11	Pipe Boot (east)	3'x5'	1/17/01	RV	P

36

R002057

Appendix G

Geomembrane Destructive Seam Laboratory Test Results



Precision Geosynthetic Laboratories

January 16, 2001

R002059

ISO 9002



Mr. Marty Cieslik
FOTH & VAN DYKE
406 Science Drive
Madison, WI 53711

Dear Mr. Cieslik:

RE: Modern Plating / 97M015

Thank you for consulting Precision Geosynthetic Laboratories for your material testing needs.

It should be noted that the test specimen and test sample used for this report was believed to be representative of the material produced under the designation herein stated. However, these results are indicative of only the specimens that were actually tested. The testing herein is based upon accepted industry practice as well as the test method listed. Precision Geosynthetic Laboratories neither accepts responsibility for nor makes claims to the final use and purpose of the material.

By accepting the data and results represented on this report, Client agrees to limit the liability of Precision Geosynthetic Laboratories from Client and all other parties for claims arising out of the use of this data to the cost for the respective test(s) represented in this report, and Client agrees to indemnify and hold harmless Precision Geosynthetic Laboratories from and against all liability in excess of the aforementioned limit.

The test data and all associated project information shall be held in confidence and disclosed to other parties only with the authorization of Client or Precision Geosynthetic Laboratories.

It is a company policy to keep the physical records of each job for 2 years since the receipt of the samples and keep the electronic file for 7 years. **Failed seam samples are kept for 7 years; good seam samples are disposed after 2 weeks and conformance samples are disposed after 1 month.** Should you need us to keep them longer, please advise us in writing.

If you have any questions or if we may be of further service, please do not hesitate to call at 800-522-4599.

Sincerely,

PRECISION GEOSYNTHETIC LABORATORIES

Edith Pintor
Quality Assurance

Cora B. Queja
Vice President

Enclosure: (Job No. J010012)

1160 North Gilbert Street, Anaheim, CA 92801, Tel # 714-520-9631, Fax # 714-520-9637



Precision Geosynthetic Laboratories

CLIENT: FOTH & VAN DYKE
PROJECT: Modern Plating / 97M015

ISO 9002



VERIFICATION OF MATERIAL PROPERTIES (PGL Job No. J010012)

MATERIAL DESCRIPTION: 40 mil HDPE seam

SAMPLED BY: FOTH & VAN DYKE

DATE RECEIVED: January 16, 2001

DATE REPORTED: January 16, 2001

SAMPLE IDENTIFICATIONS:

SAMPLE ID	PRECISION CONTROL NUMBER
DT- 1B P2/ 3	65348
DT- 1A P1/ 9	65349
DT- 6 P6/ 8	65350
DT- 2 P9/ 10	65351
DT- 1 P4/ 5	65352
DT- 3 P14/ 15	65353
DT- 5 P19/ 23	65354
DT- 4 P18/ 21	65355

TESTS REQUIRED:

DESCRIPTION	TEST METHOD
Seam Peel Adhesion	ASTM D4437
Bonded Seam Strength	ASTM D4437

TEST CONDITIONS: The samples were conditioned for a minimum one hour in the laboratory at 22 ± 2°C (71.6 ± 3.6°F) and at 60 ± 10% relative humidity prior to test.

TEST RESULTS:

The test results are summarized in Tables 1 through 5. The units in which the data are reported are included on the tables. Break types are defined as Film- tear bond (FTB) and separation (AD).

PRECISION GEOSYNTHETIC LABORATORIES



Edith Pintor
Quality Assurance

Cora B. Queja
Vice President

1160 North Gilbert Street, Anaheim, CA 92801, Tel # 714-520-9631, Fax # 714-520-9637

**TABLE 1.
SEAM PEEL AND SHEAR TEST RESULTS**

CLIENT: **FOTH & VAN DYKE**
 PROJECT: **Modern Plating / 97M015**
 DATE REC'D: **16-Jan-01**

MATERIAL: **40 Mil HDPE**
 SEAM TYPE: **Heat Fusion Weld**
 PGL JOB #: **J010012**

QC'd By: *[Signature]*
 TEST METHOD: **ASTM D4437**
 DATE REPORT: **16-Jan-01**

SAMPLE ID	PGL CONTROL #	SHEAR EVALUATION				PEEL EVALUATION					
		MAXIMUM STRENGTH (lb/in)	ELONGATION @ BREAK (%)	NSF 54 FAILURE MODE	PROJECT SPEC. (lb/in)	SPECIMEN NUMBER	MAXIMUM STRENGTH (lb/in)	% PEEL (%)	LOCUS OF FAILURE	NSF 54 FAILURE MODE	PROJECT SPEC. (lb/in)
DT- 1B P2/ 3	65348	138	>50	FTB		1 Outside	80	<10	SE1	FTB	
		132	>50	FTB		2 Outside	94	<10	SE1	FTB	
		132	>50	FTB		3 Outside	80	<10	SE1	FTB	
		136	>50	FTB		4 Outside	87	<10	SE1	FTB	
		141	>50	FTB		5 Outside	91	<10	SE1	FTB	
		AVG:		136				86			
STD. DEV.		4				6					
DT- 1A P1/ 9	65349	132	>50	FTB		1 Inside	95	<10	SE1	FTB	
		124	>50	FTB		2 Inside	98	<10	SE1	FTB	
		131	>50	FTB		3 Inside	94	<10	SE1	FTB	
		129	>50	FTB		4 Inside	99	<10	SE1	FTB	
		134	>50	FTB		5 Inside	106	<10	SE1	FTB	
		AVG:		136				98			
STD. DEV.		4				5					
AVG:		130				97					
STD. DEV.		4				4					

BREAK DESCRIPTION (NSF 54, 1993):

- AD ADHESION FAILURE.
- BRK BREAK IN SHEETING.
- SE1 BREAK AT OUTER EDGE OF SEAM.
- SE2 BREAK AT INNER EDGE OF SEAM TO EITHER BOTH SHEETS.
- AD-BRK BREAK IN FIRST SEAM AFTER SOME ADHESION FAILURE.
- FTB FILM-TEAR BOND



Precision Geosynthetic Laboratories

ISO 9002



R002061

**TABLE 2.
SEAM PEEL AND SHEAR TEST RESULTS**

CLIENT: **FOTH & VAN DYKE**
 PROJECT: **Modern Plating / 97M015**
 DATE REC'D: **16-Jan-01**

MATERIAL: **40 Mil HDPE**
 SEAM TYPE: **Extrusion Weld**
 PGL JOB #: **J010012**

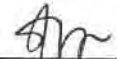
QC'd By: 
 TEST METHOD: **ASTM D4437**
 DATE REPORT: **16-Jan-01**

SAMPLE ID	PGL CONTROL #	SHEAR EVALUATION				PEEL EVALUATION						
		MAXIMUM STRENGTH (lb/in)	ELONGATION @ BREAK (%)	NSF 54 FAILURE MODE	PROJECT SPEC. (lb/in)	SPECIMEN NUMBER	MAXIMUM STRENGTH (lb/in)	% PEEL (%)	LOCUS OF FAILURE	NSF 54 FAILURE MODE	PROJECT SPEC. (lb/in)	
DT-6 P6/8	65350	131	>50	FTB		1 Outside	100	<10	SE1	FTB		
		128	>50	FTB		2 Outside	90	<10	SE1	FTB		
		136	>50	FTB		3 Outside	93	<10	SE1	FTB		
						4 Outside	101	<10	SE1	FTB		
						5 Outside	102	<10	SE1	FTB		
						AVG:	97					
						STD. DEV.	5					
						1 Inside	N/A					
						2 Inside						
						3 Inside						
				4 Inside								
				5 Inside								
	AVG.	133										
	STD. DEV.	5			AVG:	N/A						
					STD. DEV.							

BREAK DESCRIPTION (NSF 54, 1993):
 AD ADHESION FAILURE.
 BRK BREAK IN SHEETING.
 SE1 BREAK AT OUTER EDGE OF SEAM.
 SE2 BREAK AT INNER EDGE OF SEAM THROUGH BOTH SHEETS.
 AD-BRK BREAK IN FIRST SEAM AFTER SOME ADHESION FAILURE.
 FTB FILM-TEAR BOND.



Precision Geosynthetic Laboratories

N/A: NOT AVAILABLE, EXTRUSION WELD.



R002062

**TABLE 3.
SEAM PEEL AND SHEAR TEST RESULTS**

CLIENT: **FOTH & VAN DYKE**
 PROJECT: **Modern Plating / 97M015**
 DATE REC'D: **16-Jan-01**

MATERIAL: **40 Mil HDPE**
 SEAM TYPE: **Heat Fusion Weld**
 PGL JOB #: **J010012**

QC'd By: 
 TEST METHOD: **ASTM D4437**
 DATE REPORT: **16-Jan-01**

SAMPLE ID	PGL CONTROL #	SHEAR EVALUATION				PEEL EVALUATION						
		MAXIMUM STRENGTH (lb/in)	ELONGATION @ BREAK (%)	NSF 54 FAILURE MODE	PROJECT SPEC. (lb/in)	SPECIMEN NUMBER	MAXIMUM STRENGTH (lb/in)	% PEEL (%)	LOCUS OF FAILURE	NSF 54 FAILURE MODE	PROJECT SPEC. (lb/in)	
DT- 2 P9/ 10	65351	130	>50	FTB		1 Outside	88	<10	SE1	FTB		
		130	>50	FTB		2 Outside	99	<10	SE1	FTB		
		121	>50	FTB		3 Outside	100	<10	SE1	FTB		
		128	>50	FTB		4 Outside	103	<10	SE1	FTB		
		130	>50	FTB		5 Outside	90	<10	SE1	FTB		
		AVG:		96								
		STD. DEV.		7								
				1 Inside	90	<10	SE1	FTB				
				2 Inside	94	<10	SE1	FTB				
				3 Inside	96	<10	SE1	FTB				
				4 Inside	101	<10	SE1	FTB				
		5 Inside	90	<10	SE1	FTB						
AVG:		94										
STD. DEV.		5										
DT- 1 P4/ 5	65352	130	>50	FTB		1 Outside	83	100	AD	Non-FTB		
		128	>50	FTB		2 Outside	54	100	AD	Non-FTB		
		125	>50	FTB		3 Outside	75	100	AD	Non-FTB		
		128	>50	FTB		4 Outside	70	100	AD	Non-FTB		
		129	>50	FTB		5 Outside	64	100	AD	Non-FTB		
		AVG:		69								
		STD. DEV.		11								
				1 Inside	104	<10	SE1	FTB				
				2 Inside	95	<10	SE1	FTB				
				3 Inside	103	<10	SE1	FTB				
				4 Inside	99	<10	SE1	FTB				
		5 Inside	100	<10	SE1	FTB						
AVG:		100										
STD. DEV.		4										

BREAK DESCRIPTION (NSF 54, 1993):

- AD ADHESION FAILURE.
- BRK BREAK IN SHEETING.
- SE1 BREAK AT OUTER EDGE OF SEAM.
- SE2 BREAK AT INNER EDGE OF SEAM THROUGH BOTH SHEETS.
- AD-BRK BREAK IN FIRST SEAM AFTER SOME ADHESION FAILURE.
- FTB FILM-TEAR BOND.



Precision Geosynthetic Laboratories

ISO 9002



R002063

**TABLE 4.
SEAM PEEL AND SHEAR TEST RESULTS**

CLIENT: **FOTH & VAN DYKE**
 PROJECT: **Modern Plating / 97M015**
 DATE REC'D: **16-Jan-01**

MATERIAL: **40 Mil HDPE**
 SEAM TYPE: **Heat Fusion Weld**
 PGL JOB #: **J010012**

QC'd By: 
 TEST METHOD: **ASTM D4437**
 DATE REPORT: **16-Jan-01**

SAMPLE ID	PGL CONTROL #	SHEAR EVALUATION				PEEL EVALUATION						
		MAXIMUM STRENGTH (lb/in)	ELONGATION @ BREAK (%)	NSF 54 FAILURE MODE	PROJECT SPEC. (lb/in)	SPECIMEN NUMBER	MAXIMUM STRENGTH (lb/in)	% PEEL (%)	LOCUS OF FAILURE	NSF 54 FAILURE MODE	PROJECT SPEC. (lb/in)	
DT-3 P14/15	65353	130	>50	FTB		1 Outside	98	<10	SE1	FTB		
		128	>50	FTB		2 Outside	97	<10	SE1	FTB		
		131	>50	FTB		3 Outside	100	<10	SE1	FTB		
		131	>50	FTB		4 Outside	96	<10	SE1	FTB		
		133	>50	FTB		5 Outside	97	<10	SE1	FTB		
		AVG:		98								
		STD. DEV.		2								
				1 Inside	89	<10	SE1	FTB				
				2 Inside	83	<10	SE1	FTB				
				3 Inside	93	<10	SE1	FTB				
				4 Inside	101	<10	SE1	FTB				
		5 Inside	96	<10	SE1	FTB						
AVG:		131										
STD. DEV.		2										
DT-5 P19/23	65354	126	>50	FTB		1 Outside	95	<10	SE1	FTB		
		126	>50	FTB		2 Outside	90	<10	SE1	FTB		
		127	>50	FTB		3 Outside	106	25	AD-BRK	FTB		
		124	>50	FTB		4 Outside	112	<10	SE1	FTB		
		131	>50	FTB		5 Outside	99	<10	SE1	FTB		
		AVG:		100								
		STD. DEV.		9								
				1 Inside	101	<10	SE1	FTB				
				2 Inside	93	<10	SE1	FTB				
				3 Inside	103	<10	SE1	FTB				
				4 Inside	98	<10	SE1	FTB				
		5 Inside	94	<10	SE1	FTB						
AVG:		127										
STD. DEV.		3										
AVG:		98										
STD. DEV.		4										

BREAK DESCRIPTION (NSF 54, 1993):
 AD ADHESION FAILURE.
 BRK BREAK IN SHEETING.
 SE1 BREAK AT OUTER EDGE OF SEAM.
 SE2 BREAK AT INNER EDGE OF SEAM THROUGH BOTH SHEETS.
 AD-BRK BREAK IN FIRST SEAM AFTER SOME ADHESION FAILURE.
 FTB FILM-TEAR BOND.



Precision Geosynthetic Laboratories

ISO 9002



R002064

**TABLE 5.
SEAM PEEL AND SHEAR TEST RESULTS**

CLIENT: **FOTH & VAN DYKE**
 PROJECT: **Modern Plating / 97M015**
 DATE REC'D: **16-Jan-01**

MATERIAL: **40 Mil HDPE**
 SEAM TYPE: **Heat Fusion Weld**
 PGL JOB #: **J010012**

QC'd By: 
 TEST METHOD: **ASTM D4437**
 DATE REPORT: **16-Jan-01**

SAMPLE ID	PGL CONTROL #	SHEAR EVALUATION				PEEL EVALUATION						
		MAXIMUM STRENGTH (lb/in)	ELONGATION @ BREAK (%)	NSF 54 FAILURE MODE	PROJECT SPEC. (lb/in)	SPECIMEN NUMBER	MAXIMUM STRENGTH (lb/in)	% PEEL (%)	LOCUS OF FAILURE	NSF 54 FAILURE MODE	PROJECT SPEC. (lb/in)	
DT- 4 P18/ 21	65355	128	>50	FTB		1 Outside	66	70	AD-BRK	FTB		
		123	>50	FTB		2 Outside	101	<10	SE1	FTB		
		127	>50	FTB		3 Outside	63	85	AD-BRK	FTB		
		131	>50	FTB		4 Outside	78	30	AD-BRK	FTB		
		120	>50	FTB		5 Outside	96	<10	SE1	FTB		
		AVG:		81								
		STD. DEV.		17								
				1 Inside	98	<10	SE1	FTB				
				2 Inside	93	<10	SE1	FTB				
				3 Inside	90	<10	SE1	FTB				
				4 Inside	91	<10	SE1	FTB				
		5 Inside	94	<10	SE1	FTB						
AVG.		126										
STD. DEV.		4										
		AVG:	93									
		STD. DEV.	3									

BREAK DESCRIPTION (NSF 54, 1993):
 AD ADHESION FAILURE.
 BRK BREAK IN SHEETING.
 SE1 BREAK AT OUTER EDGE OF SEAM.
 SE2 BREAK AT INNER EDGE OF SEAM THROUGH BOTH SHEETS.
 AD-BRK BREAK IN FIRST SEAM AFTER SOME ADHESION FAILURE.
 FTB FILM-TEAR BOND.



Precision Geosynthetic Laboratories



R002065



Precision Geosynthetic Laboratories

January 17, 2001



Mr. Marty Cieslik
FOTH & VAN DYKE
406 Science Drive
Madison, WI 53711

Dear Mr. Cieslik:

RE: Modern Plating / 97M015

Thank you for consulting Precision Geosynthetic Laboratories for your material testing needs.

It should be noted that the test specimen and test sample used for this report was believed to be representative of the material produced under the designation herein stated. However, these results are indicative of only the specimens that were actually tested. The testing herein is based upon accepted industry practice as well as the test method listed. Precision Geosynthetic Laboratories neither accepts responsibility for nor makes claims to the final use and purpose of the material.

By accepting the data and results represented on this report, Client agrees to limit the liability of Precision Geosynthetic Laboratories from Client and all other parties for claims arising out of the use of this data to the cost for the respective test(s) represented in this report, and Client agrees to indemnify and hold harmless Precision Geosynthetic Laboratories from and against all liability in excess of the aforementioned limit.

The test data and all associated project information shall be held in confidence and disclosed to other parties only with the authorization of Client or Precision Geosynthetic Laboratories.

It is a company policy to keep the physical records of each job for 2 years since the receipt of the samples and keep the electronic file for 7 years. **Failed seam samples are kept for 7 years; good seam samples are disposed after 2 weeks and conformance samples are disposed after 1 month.** Should you need us to keep them longer, please advise us in writing.

If you have any questions or if we may be of further service, please do not hesitate to call at 800-522-4599.

Sincerely,

PRECISION GEOSYNTHETIC LABORATORIES

Edith Pintor
Quality Assurance

Cera B. Queja
Vice President

Enclosure: (Job No. J010013)

1160 North Gilbert Street, Anaheim, CA 92801, Tel # 714-520-9631, Fax # 714-520-9637



Precision Geosynthetic Laboratories

CLIENT: FOTH & VAN DYKE
PROJECT: Modern Plating / 97M015

ISO 9002



VERIFICATION OF MATERIAL PROPERTIES (PGL Job No. J010013)

MATERIAL DESCRIPTION: 40 mil HDPE seam

SAMPLED BY: FOTH & VAN DYKE

DATE RECEIVED: January 17, 2001

DATE REPORTED: January 17, 2001

SAMPLE IDENTIFICATIONS:

SAMPLE ID	PRECISION CONTROL NUMBER
DT- 4A P18/ 22	65356
DT- 4B P18/ 22	65357

TESTS REQUIRED:

DESCRIPTION	TEST METHOD
Seam Peel Adhesion	ASTM D4437
Bonded Seam Strength	ASTM D4437

TEST CONDITIONS: The samples were conditioned for a minimum one hour in the laboratory at $22 \pm 2^{\circ}\text{C}$ ($71.6 \pm 3.6^{\circ}\text{F}$) and at $60 \pm 10\%$ relative humidity prior to test.

TEST RESULTS:

The test results are summarized in Table 1. The units in which the data are reported are included on the tables. Break types are defined as Film- tear bond (FTB) and separation (AD).

PRECISION GEOSYNTHETIC LABORATORIES



Edith Pintor
Quality Assurance

Cora B. Queja
Vice President

**TABLE 1.
SEAM PEEL AND SHEAR TEST RESULTS**

CLIENT: **FOTH & VAN DYKE**
 PROJECT: **Modern Plating / 97M015**
 DATE REC'D: **17-Jan-01**

MATERIAL: **40 Mil HDPE**
 SEAM TYPE: **Heat Fusion Weld**
 PGL JOB #: **J010013**

QC'd By: *[Signature]*
 TEST METHOD: **ASTM D4437**
 DATE REPORT: **17-Jan-01**

SAMPLE ID	PGL CONTROL #	SHEAR EVALUATION				PEEL EVALUATION						
		MAXIMUM STRENGTH (lb/in)	ELONGATION @ BREAK (%)	NSF 54 FAILURE MODE	PROJECT SPEC. (lb/in)	SPECIMEN NUMBER	MAXIMUM STRENGTH (lb/in)	% PEEL (%)	LOCUS OF FAILURE	NSF 54 FAILURE MODE	PROJECT SPEC. (lb/in)	
DT- 4A P18/ 22	65356	128	>50	FTB		1 Outside	94	<10	SE1	FTB		
		117	>50	FTB		2 Outside	96	<10	SE1	FTB		
		130	>50	FTB		3 Outside	91	<10	SE1	FTB		
		129	>50	FTB		4 Outside	92	<10	SE1	FTB		
		123	>50	FTB		5 Outside	93	<10	SE1	FTB		
		AVG:		125				93				
		STD. DEV.		5				2				
		1 Inside		93	<10	SE1	FTB					
		2 Inside		86	<10	SE1	FTB					
		3 Inside		99	<10	SE1	FTB					
4 Inside		98	<10	SE1	FTB							
5 Inside		103	<10	SE1	FTB							
AVG:		126				96						
STD. DEV.		4				7						
DT- 4B P18/ 22	65357	121	>50	FTB		1 Outside	101	<10	SE1	FTB		
		125	>50	FTB		2 Outside	95	<10	SE1	FTB		
		130	>50	FTB		3 Outside	93	<10	SE1	FTB		
		129	>50	FTB		4 Outside	102	<10	SE1	FTB		
		125	>50	FTB		5 Outside	94	<10	SE1	FTB		
		AVG:		126				97				
		STD. DEV.		4				4				
		1 Inside		100	<10	SE1	FTB					
		2 Inside		99	<10	SE1	FTB					
		3 Inside		97	<10	SE1	FTB					
4 Inside		101	<10	SE1	FTB							
5 Inside		101	<10	SE1	FTB							
AVG:		126				100						
STD. DEV.		4				2						

BREAK DESCRIPTION (NSF 54, 1993):
 AD ADHESION FAILURE.
 BRK BREAK IN SHEETING.
 SE1 BREAK AT OUTER EDGE OF SEAM.
 SE2 BREAK AT INNER EDGE OF SEAM THROUGH BOTH SHEETS.
 AD-BRK BREAK IN FIRST SEAM AFTER SOME ADHESION FAILURE.
 FTB FILM-TEAR BOND.



Precision Geosynthetic Laboratories



R002068

Appendix H

Geocomposite Material Information

- H1 - Geocomposite Manufacturer's Information**
- H2 - Geocomposite Conformance Laboratory Results**

Appendix H1

Geocomposite Manufacturer's Information

EVERGREEN
TECHNOLOGIES, INC.

May 18, 2000

Mr. Benjamin Velasquez
Midessa Industrial Vinyl Co.
4809 W. 42nd Street
Odessa, TX 79764

**SUBJECT: Technical Submittal - ETI Geocomposite and Geonet for Modern
Plating CAMU Landfill - Freeport, IL**

Dear Mr. Velasquez:

The following is a brief outline regarding the Geotextile, Geonet and Geocomposite manufactured by Evergreen Technologies, Incorporated. ETI has more than sixteen years of experience in manufacturing nonwoven geotextiles, geonets and geocomposites. We were the first company to manufacture synthetic drainage geonets and geocomposites and pioneered the system of replacing conventional sand and gravel drainage materials in landfill applications. ETI has sold more than 200,000,000 square feet of drainage products and is the only company producing geonets, geocomposites and geotextiles in one location as a single-source manufacturer

ETI drainage net is a three dimensional polyethylene net structure formed by intersecting strands and providing uniform channels, open area and thickness to assure uniform flow throughout the structure. It is crush resistant and has a low compressibility capable of maintaining high transmissivity under a range of loading conditions. The geonet is manufactured with carbon black to provide ultra-violet stabilization.

ETI drainage composites consist of a three dimensional polyethylene net with a continuous filament, nonwoven, polypropylene, needle-punched geotextile heat bonded to one or both sides of the drainage net core.

ETI Geotextiles are manufactured from one hundred percent polypropylene polymer. During the pre-extrusion heating process, a very effective ultra-violet light stabilizer is thoroughly mixed into the molten polymer. The resulting extruded filament is continuously drawn down from the top of the extrusion tower by an air current traveling at approximately 4 - 6 thousands m/min. During this "draw down" process the fiber is stretched and this results in a sophisticated molecular re-orientation.



5883 Glenridge Drive / Suite 200 / Atlanta, Georgia 30328
Tel. 800-984-9784 / Fax 404-705-9650

200 Miller Sellers Drive / Evergreen, Alabama 36401
Tel. 334-578-9003 / Fax 334-578-6141

The fiber is then randomly laid out and carried on a conveyor belt into a series of needling machines. Each of these contains literally thousands of barbed needles, which move up and down through the web of fibers causing a complete entanglement. After leaving the last needling machine, the fabric is drawn into a heated stretching chamber. Here it is stretched both in machine and cross machine direction to optimize the isometric properties of the finished geotextile. Finally, the nonwoven geotextile is rolled, packaged and placed in storage ready for shipment. Each stage of the process, from acceptance of polymer to the placing of the product in a storage area location is recorded in a computerized sequence. Every single roll which leaves Evergreen Technologies' production line can be traced back to the details of each segment of its manufacture and each quality assurance test to which samples of its production batch were taken. This unique process allows Evergreen Technologies to produce a variety of needle-free spunbonded, needle-punched, nonwoven geotextiles which currently range from 3 to 28 ounces per square yard (100 to 950 g/m²).

After a detailed review of the project specifications, ETI finds no discrepancies with the manufacturer's properties, test methods, or test frequencies.

If you have any questions or require any additional information please don't hesitate to contact me directly at 800-984-9784.

Sincerely,



Billy Carruth
Technical Representative
Evergreen Technologies, Inc.

GEOCOMPOSITE DC4200/TG600

DC4200/TG600 is a drainage geocomposite made by thermally bonding Evergreen Technologies U.V. stabilized, spunbonded, continuous filament, needlepunched, nonwoven, polypropylene 6 ounce per square yard geotextile to **both** sides of our chemically resistant high density polyethylene **NS1400** geonet core. ETI geocomposites have high compressive strength in order to ensure maximum flow capacity of both liquids and gases under high confining pressures, and exhibit high ply adhesion strengths to ensure performance of the composite as a single unit. Virgin resins used in the production of ETI geonets consist of at least 97% polyethylene with a melt flow range between 0.1 and 1.0 grams per 10 minutes (ASTM D1238), and a density range of 0.932 to 0.970 grams per cubic centimeter (ASTM D1505). The geocomposite is delivered to the jobsite in roll form with each roll having unique identification and QA traceability. **DC4200/TG600** conforms to the property values listed in the tables below.

PROPERTY	TEST METHODS	UNITS	VALUE	SPECIFICATIONS ¹	TEST FREQUENCY
FINISHED GEOCOMPOSITE PROPERTIES					
• Transmissivity ³ nominal pressure = 15000psf; i=1.0	ASTM D 4716 plate/composite/plate	m ² /sec (E-04)	1.0	MARV	200,000 sf (or per project req.)
• Peel Adhesion	ASTM F 904 (modified) ²	g/in	454	MARV	50,000 sf
• Geotextile overlap at edges and unbonded area		in	3.0	nominal	
		mm	75		
CORE NET PROPERTIES (97% minimum virgin polyethylene resin)					
• MD Tensile	ASTM D 5035	ppi	48	MARV	50,000 sf
		kN/m	8.4		
• Thickness	ASTM D 5199	mil	200	MARV	50,000 sf
		mm	5.1		
• Carbon Black	ASTM D 4218 (or ASTM D 1603)	% weight	2.0	MARV	50,000 sf
GEOTEXTILE PROPERTIES					
• Grab Tensile	ASTM D 4632	lbs	160	MARV	100,000 sf
		N	712		
• AOS	ASTM D 4751	US Std. Sieve	70	MARV	500,000 sf
		mm	0.212		
• Mass/Unit Area	ASTM D 5261	oz/yd ²	6.0	MARV	100,000 sf
• Water Permeability	ASTM D 4491	cm/sec	0.3	MARV	500,000 sf
• Water Flow Rate	ASTM D 4491	gpm/ft ²	135	MARV	500,000 sf
		m ³ /sec/m ²	0.08		
• U.V. Resistance	ASTM G 53	%	70		1 per lot
PACKAGING					
• Roll length	Direct Measure	ft	225	nominal	Each roll
• Roll width	Direct Measure	ft	14	nominal	Each roll
• Roll weight	Direct Measure	lbs	903	typical	Each roll
• Roll diameter	Direct Measure	in	31	typical	Each roll
• Core ID	Direct Measure	in	4	nominal	N/A
• Labeling:	Product code, geotextile type, roll dimensions, finished product lot and roll number.				

Notes
¹ MARV is defined as the one-sided 97.5% confidence limit obtained through long-term data (mean - 2* standard deviations) and represents the minimum allowable sample roll average for each specific test.
² Peel adhesion ASTM F 904: 2 inch wide strip. Reported value per specimen is average of all computed points between 1" and 5" of separation.
³ Transmissivity results reported by Evergreen Technologies, Inc. are based on standard index test conditions. Actual performance is dependent upon site specific conditions. Please contact Evergreen Technologies Technical Service for site specific transmissivity testing.
⁴ Geotextile and Core Net component properties are tested prior to the lamination process and cannot be tested on the finished geocomposite product.



Sales/Technical Service

5775-B Glenridge Drive • Lakeside Center, Suite 450 • Atlanta, Georgia 30328-5363 • 404.250.1290 • 404.705.9650 (fax) • 800.984.9784
 www.etigeo.com

Manufacturing/Quality Assurance

200 Miller Sellers Drive • Evergreen, Alabama 36401 • (Main Tel.) 334.578.9003 • 334.578.6141 (fax)

QA Direct

334.578.6103 • 334.578.6140 (fax)

EVERGREEN
TECHNOLOGIES, INC.

May 18, 2000

Midessa Industrial Vinyl Co.
4809 W. 42nd Street
Odessa, TX 79764
Attn: Mr. Benjamin Velasquez

Subject: DC4200AA Product Pre-Certification for Modern Plating CAMU Landfill-Freeport, IL

Dear Mr. Valasquez:

This letter is to certify that DC4200AA is a Geonet Drainage Composite manufactured by Evergreen Technologies, Inc. (ETI). Further, all of the components are manufactured by ETI. The components consist of TG600, a 6-ounce metal-free nonwoven geotextile from a Lot # to be determined, which is bonded to each side of a Geonet (NS1400) from a Lot # to be determined.

DC4200AA meets the minimum properties listed below:

PROPERTY	TEST PROCEDURE	VALUE (1)
Peel Adhesion	ASTM F 904	2 lbs/in
Transmissivity (2)	ASTM D 4716	3.0 $\times 10^{-5}$ m ² /sec

(1) Unless noted otherwise, these values represent minimum average roll values (i.e. test results from any sampled roll in a lot, tested in accordance with ASTM D 4759-88 which meet or exceed the minimum values listed with a 97.7% level of confidence).

(2) Transmissivity test parameters were set at gradient of 1.0, pressure load of 15,000 pounds per square foot (psf), with a configuration of metal plate / sample / metal plate, 15 minutes seating time.

This certification is based on testing conducted by ETI Quality Assurance & Quality Control testing laboratory at the time of manufacturing. ETI issues this letter of certification to indicate our commitment to providing our customers with a quality product which will meet or exceed the minimum average roll values in accordance with the applicable American Society for Testing and Materials (ASTM) test method.

Respectfully,



Jonathan McCulley
QA / QC Supervisor



5883 Glenridge Drive / Suite 200 / Atlanta, Georgia 30328

Tel. 800-984-9784 / Fax 404-705-9650

200 Miller Sellers Drive / Evergreen, Alabama 36401

Tel. 334-578-9003 / Fax 334-578-6141

EVERGREEN
TECHNOLOGIES, INC.

May 18, 2000

Midessa Industrial Vinyl Co.
4809 W. 42nd Street
Odessa, TX 79764
Attn: Mr. Benjamin Velasquez

Subject: TG600 Geotextile Product Pre-Certification for Modern Plating CAMU Landfill- Freeport, IL

Dear Mr. Valasquez:

This letter certifies that TG600, a metal-free nonwoven geotextile, shipped from Evergreen, Alabama, manufactured by Evergreen Technologies, meets or exceeds the minimum requirements listed below and was shipped from Lot # to be determined.

PROPERTY	TEST PROCEDURE	VALUE(1)	
Tear Strength	ASTM D 4533	25	lbs
Mullen Burst	ASTM D 3786	130	psi
Grab Strength	ASTM D 4632	80	lbs
Puncture Resistance	ASTM D 4833	25	lbs
A.O.S. (2)	ASTM D 4751	.212-.150	* mm
		(70-100)	* US Std Sieve
U.V. Resistance (500 hours)	ASTM D 4355	70	%

(1) Values in weaker principle direction. Unless noted otherwise, these values represent minimum average roll values (i.e. test results from any sampled roll in a lot, tested in accordance with ASTM D 4759-88 shall meet or exceed the minimum values listed with a 97.7% level of confidence).

(2) Smaller sieve size number represents the maximum average roll value.

* Determined at the time of manufacturing, storage and handling conditions which differ from those found in ASTM D 4873-88 may influence these properties.

Unless noted otherwise, this certification is based on testing conducted by Evergreen Technologies Quality Assurance & Quality Control testing laboratories at the time of manufacturing. Evergreen Technologies issues this letter of certification to indicate our commitment to providing our customers with a quality product which will meet or exceed the minimum average roll values in accordance with the applicable American Society for Testing and Materials (ASTM) test method.

Respectfully,



Jonathan McCulley
QA / QC Supervisor

ETI

5883 Glenridge Drive / Suite 200 / Atlanta, Georgia 30328

Tel. 800-984-9784 / Fax 404-705-9650

200 Miller Sellers Drive / Evergreen, Alabama 36401

Tel. 334-578-9003 / Fax 334-578-6141

EVERGREEN
TECHNOLOGIES, INC.

May 18, 2000

Midessa Industrial Vinyl Co.
4809 W. 42nd Street
Odessa, TX 79764
Attn: Mr. Benjamin Velasquez

Subject: NS1400 Geonet Product Pre-Certification for Modern Plating CAMU Landfill- Freeport, IL

Dear Mr. Valasquez

This letter certifies that NS1400, a 200 mil geonet shipped from Evergreen, Alabama, manufactured by Evergreen Technologies, meets or exceeds the minimum requirements listed below and was shipped from Lot # to be determined.

PROPERTY	TEST PROCEDURE	VALUE(1)
Transmissivity (2)	ASTM D 4716	1 x10 ⁻⁴ m ² /sec
Carbon Black Content	ASTM D 4218	2-3 %

Resin Information

A minimum 97% virgin polyethylene is used to produce NS1400. Railcar Number to be determined, HDPE.

PROPERTY	TEST PROCEDURE	VALUE
Melt Flow Range	ASTM D 1238	1.0 g/10 max
Density	ASTM D 1505	0.940 g/cc

(1) Unless noted otherwise, these values represent minimum average roll values (i.e. test results from any sampled roll in a lot, tested in accordance with ASTM D 4759-88 which meet or exceed the minimum values listed with a 97.7% level of confidence).

(2) Transmissivity test parameters were set at gradient of 1.0, pressure load of 15,000 pounds per square foot (psf), with a configuration of metal plate / sample / metal plate, 15 minutes seating time.

This certification is based on testing conducted by ETI Quality Assurance & Quality Control testing laboratory at the time of manufacturing. ETI issues this letter of certification to indicate our commitment to providing our customers with a quality product which will meet or exceed the minimum average roll values in accordance with the applicable American Society for Testing and Materials (ASTM) test method.

Respectfully,



Jonathan McCulley
QA / QC Supervisor



5883 Glenridge Drive / Suite 200 / Atlanta, Georgia 30328

Tel. 800-984-9784 / Fax 404-705-9650

200 Miller Sellers Drive / Evergreen, Alabama 36401

Tel. 334-578-9003 / Fax 334-578-6141

BILL OF LADING—SHORT FORM—NOT NEGOTIABLE

Carrier L&L TRUCKING	LLTR	Trailer No. 1812	Date 06/09/2000	Shipment No. 4677	Bill of Lading No. R002078 4669
------------------------------------	------	---------------------	--------------------	-----------------------------	--

RECEIVED, subject to the classifications and lawfully allowed tariffs in effect on the date of issue of this Bill of Lading.

The property described below in apparent good order, except as noted (contents and condition of contents of packages unknown), marked, consigned, and destined as indicated below which said carrier (the word carrier being understood throughout this contract as any person or corporation in possession of the property under the contract) agrees to carry to its usual place of delivery at said destination, if on its route, otherwise to deliver to another carrier on the route to said destination. It is mutually agreed as to each carrier of all or any said property over all or any portion of said route to destination, and as to each party at any time interested in all or any said property, that every service to be performed hereunder shall be subject to all the terms and conditions of the Uniform Domestic Straight Bill of Lading set forth (1) in Uniform Freight Classification in effect on the date hereof, if this is a rail or a rail-water shipment, or (2) in the applicable motor carrier classification or tariff if this is a motor carrier shipment.

Shipper hereby certifies that he is familiar with all the terms and conditions of the said bill of lading, set forth in the classification or tariff which governs the transportation of this shipment and the said terms and conditions are hereby agreed to by the shipper and accepted for himself and his assigns.

From: Shipper EVERGREEN TECHNOLOGIES, INC. (Origin) 200 MILLER SELLERS DRIVE EVERGREEN, AL 36401	To: Cosignee MIDESSA INDUSTRIAL VINYL CO MODERN PLATING CORP 701 S HANCOCK FREEPORT, IL 61032
--	--

ETI Order Number: 0001858-00 Customer Purchase Order: 0 Job Number:

TES/TET#: TMP#: Freight Terms: PPD

Order TES-2427 / TMP #
 Comments PLEASE FAX THEN MAIL CERTS TO BENJAMIN VELASQUEZ AT FAX # 915-381-2082. IF DELIVERY PROBLEMS, PLEASE CONTACT BENJAMIN AT 915-530-3055.

Bill of Lading Comments

No. Pkgs	Kind of Package, Description of Articles, Special Marks and Exceptions	Weight
1	DC4200AA168155 DC4200/ 6oz/6oz 14x155 2,170ft2	645
21	DC4200AA168225 DC4200 6oz/6oz 14x225 3,150ft2	19,656
1	NS1300168280 NS1300 14x280 3,920ft2	756
4	NS1300168300 NS1300 14x300 4,200ft2	3,240

27 Total Pkgs Total Weight 24,297 lbs

Cosignee Signature		Delivery Date
REMIT C.O.D. TO:	C.O.D. Amt\$	C.O.D Fee: <input type="checkbox"/> Prepaid <input type="checkbox"/> Collect \$
Subject to Section 7 of conditions, if this shipment is to be delivered to the cosignee without recourse on the cosignor, the cosignor shall sign the following statement: The carrier shall not make delivery of the shipment without payment of freight and all other lawful charges.		Freight charges are PREPAID unless marked collect. <input type="checkbox"/> Check box if charges are Collect. <input type="checkbox"/>
_____ (Signature of Cosignor)		
This is to certify that the above named materials are properly classified, described, packaged, marked and labeled, and are in proper condition for transportation, according to the applicable regulations of the Department of Transportation.		
EVERGREEN TECHNOLOGIES, INC. 200 MILLER SELLERS DRIVE - EVERGREEN, AL 36401 Permanent post office address of shipper		Shipper, Per <i>Russell Cobin</i> Agent, Per <i>Noah Benton</i>

Evergreen Technologies, Inc.
Packing List

Customer MID010

MIDESSA INDUSTRIAL VINCENNES IN 002079

9 Jun-00

14:19:26

Ship To:

MODERN PLATING CORP

Order Number 0001858-00

PO Number: 0

701 S HANCOCK

Shipment Number: 4677

FREEPORT, IL 61032

Line	Roll Number	Lot Number	Product Code
1	0300883	03019	NS1300168300
2	0300884	03019	NS1300168300
3	0300885	03019	NS1300168300
4	0300886	03019	NS1300168300
5	0403316	04022	DC4200AA168225
6	0403324	04022	DC4200AA168225
7	0403325	04022	DC4200AA168225
8	0403326	04022	DC4200AA168225
9	0403327	04022	DC4200AA168225
10	0403332	04022	DC4200AA168225
11	0403338	04022	DC4200AA168155
12	0403339	04022	DC4200AA168225
13	0403344	04022	DC4200AA168225
14	0403345	04022	DC4200AA168225
15	0403346	04022	DC4200AA168225
16	0403347	04022	DC4200AA168225
17	0403348	04022	DC4200AA168225
18	0403349	04022	DC4200AA168225
19	0403350	04022	DC4200AA168225
20	0403351	04022	DC4200AA168225
21	0403358	04022	DC4200AA168225
22	0403359	04022	DC4200AA168225
23	0403362	04022	DC4200AA168225
24	0403365	04022	DC4200AA168225
25	0403366	04022	DC4200AA168225
26	0403367	04022	DC4200AA168225
27	9305424	93161	NS1300168280

Carrier: SASSY TRUCKING SAS Trailer No. 130 Date: 06/09/2000 Shipment No. 4678 R002080 Bill of Lading No. 4668

RECEIVED, subject to the classifications and lawfully allowed tariffs in effect on the date of issue of this Bill of Lading. The property described below in apparent good order, except as noted (contents and condition of contents of packages unknown), marked, consigned, and destined as indicated below which said carrier (the word carrier being understood throughout this contract as any person or corporation in possession of the property under the contract) agrees to carry to its usual place of delivery at said destination, if on its route, otherwise to deliver to another carrier on the route to said destination. It is mutually agreed as to each carrier of all or any said property over all or any portion of said route to destination, and as to each party at any time interested in all or any said property, that every service to be performed hereunder shall be subject to all the terms and conditions of the Uniform Domestic Straight Bill of Lading set forth (1) in Uniform Freight Classification in effect on the date hereof, if this is a rail or a rail-water shipment, or (2) in the applicable motor carrier classification or tariff if this is a motor carrier shipment. Shipper hereby certifies that he is familiar with all the terms and conditions of the said bill of lading, set forth in the classification or tariff which governs the transportation of this shipment and the said terms and conditions are hereby agreed to by the shipper and accepted for himself and his assigns.

From: Shipper (Origin) EVERGREEN TECHNOLOGIES, INC. 200 MILLER SELLERS DRIVE EVERGREEN, AL 36401 To: Cosignee MIDESSA INDUSTRIAL VINYL CO MODERN PLATING CORP 701 S HANCOCK FREEPORT, IL 61032

ETI Order Number: 0001858-00 Customer Purchase Order: 0 Job Number:

TES/TET#: TMP#: Freight Terms: PPD

Order Comments: TES-2427 / TMP # PLEASE FAX THEN MAIL CERTS TO BENJAMIN VELASQUEZ AT FAX # 915-381-2082. IF DELIVERY PROBLEMS, PLEASE CONTACT BENJAMIN AT 915-530-3055.

Bill of Lading Comments

No. Pkgs	Kind of Package, Description of Articles, Special Marks and Exceptions	Weight
1	DC4200AA168200 DC4200/ 6oz/6oz 14x200 2,800ft2	832
1	DC4200AA168205 DC4200/6oz/6oz 14x205 2,870ft2	853
25	DC4200AA168225 DC4200 6oz/6oz 14x225 3,150ft2	23,400
27	Total Pkgs	Total Weight 25,085 lbs

Cosignee Signature _____ Delivery Date _____

REMIT C.O.D. TO: _____ C.O.D. Amt\$ _____ C.O.D Fee: Prepaid Collect \$

Subject to Section 7 of conditions, if this shipment is to be delivered to the cosignee without recourse on the cosignor, the cosignor shall sign the following statement:
The carrier shall not make delivery of the shipment without payment of freight and all other lawful charges.

Freight charges are PREPAID unless marked collect. Check box if charges are Collect.

(Signature of Cosignor)

This is to certify that the above named materials are properly classified, described, packaged, marked and labeled, and are in proper condition for transportation, according to the applicable regulations of the Department of Transportation.

EVERGREEN TECHNOLOGIES, INC. 200 MILLER SELLERS DRIVE - EVERGREEN, AL 36401 Shipper, Per *Russell* Agent, Per *Blubb*

Permanent post office address of shipper

Evergreen Technologies, Inc.
Packing List

Customer MID010

MIDESSA INDUSTRIAL **R002081**

9-Jun-00 13:57:26

Ship To:

MODERN PLATING CORP

701 S HANCOCK

FREEPORT, IL 61032

Order Number 0001858-00

PO Number: 0

Shipment Number: 4678

Line	Roll Number	Lot Number	Product Code
1	0403323	04022	DC4200AA168225
2	0403328	04022	DC4200AA168200
3	0403329	04022	DC4200AA168225
4	0403330	04022	DC4200AA168225
5	0403331	04022	DC4200AA168225
6	0403333	04022	DC4200AA168225
7	0403334	04022	DC4200AA168225
8	0403335	04022	DC4200AA168225
9	0403336	04022	DC4200AA168225
10	0403337	04022	DC4200AA168225
11	0403340	04022	DC4200AA168225
12	0403341	04022	DC4200AA168225
13	0403342	04022	DC4200AA168225
14	0403343	04022	DC4200AA168225
15	0403352	04022	DC4200AA168225
16	0403353	04022	DC4200AA168205
17	0403354	04022	DC4200AA168225
18	0403355	04022	DC4200AA168225
19	0403356	04022	DC4200AA168225
20	0403357	04022	DC4200AA168225
21	0403361	04022	DC4200AA168225
22	0403363	04022	DC4200AA168225
23	0403364	04022	DC4200AA168225
24	0403368	04022	DC4200AA168225
25	0403369	04022	DC4200AA168225
26	0403370	04022	DC4200AA168225
27	0403371	04022	DC4200AA168225

Carrier BOYD BROTHERS TRANSPORTATION	BOYD Trailer No. 48930	Date 06/12/2000	Shipment No. 4686R002082	Bill of Lading No. 4677
--	-------------------------------------	---------------------------	------------------------------------	-----------------------------------

RECEIVED, subject to the classifications and lawfully allowed tariffs in effect on the date of issue of this Bill of Lading.
 The property described below in apparent good order, except as noted (contents and condition of contents of packages unknown), marked, consigned, and destined as indicated below which said carrier (the word carrier being understood throughout this contract as any person or corporation in possession of the property under the contract) agrees to carry to its usual place of delivery at said destination, if on its route, otherwise to deliver to another carrier on the route to said destination. It is mutually agreed as to each carrier of all or any said property over all or any portion of said route to destination, and as to each party at any time interested in all or any said property, that every service to be performed hereunder shall be subject to all the terms and conditions of the Uniform Domestic Straight Bill of Lading set forth (1) in Uniform Freight Classification in effect on the date hereof, if this is a rail or a rail-water shipment, or (2) in the applicable motor carrier classification or tariff if this is a motor carrier shipment.
 Shipper hereby certifies that he is familiar with all the terms and conditions of the said bill of lading, set forth in the classification or tariff which governs the transportation of this shipment and the said terms and conditions are hereby agreed to by the shipper and accepted for himself and his assigns.

From: Shipper (Origin) EVERGREEN TECHNOLOGIES, INC. 200 MILLER SELLERS DRIVE EVERGREEN, AL 36401	To: Cosignee MIDESSA INDUSTRIAL VINYL CO MODERN PLATING CORP 701 S HANCOCK FREEPORT, IL 61032
---	---

ETI Order Number: 0001858-00 Customer Purchase Order: 0 Job Number:

TES/TET#: TMP#: Freight Terms: PPA

Order TES-2427 / TMP #
 Comments PLEASE FAX THEN MAIL CERTS TO BENJAMIN VELASQUEZ AT FAX # 915-381-2082. IF DELIVERY PROBLEMS, PLEASE CONTACT BENJAMIN AT 915-530-3055.

Bill of Lading
 Comments

No. Pkgs	Kind of Package, Description of Articles, Special Marks and Exceptions	Weight
1	DC4200AA168220 DC4200/ 6oz/6oz 14x220 3,080ft2	915
4	DC4200AA168225 DC4200 6oz/6oz 14x225 3,150ft2	3,744
5	Total Pkgs	Total Weight
		4,659 lbs

Cosignee Signature		Delivery Date
REMIT C.O.D. TO:	C.O.D. Amt\$	C.O.D Fee: <input type="checkbox"/> Prepaid <input type="checkbox"/> Collect \$
Subject to Section 7 of conditions, if this shipment is to be delivered to the cosignee without recourse on the cosignor, the cosignor shall sign the following statement: The carrier shall not make delivery of the shipment without payment of freight and all other lawful charges. _____ (Signature of Cosignor)		Freight charges are PREPAID unless marked collect. <input type="checkbox"/> Check box if charges are Collect.
This is to certify that the above named materials are properly classified, described, packaged, marked and labeled, and are in proper condition for transportation, according to the applicable regulations of the Department of Transportation. EVERGREEN TECHNOLOGIES, INC. 200 MILLER SELLERS DRIVE - EVERGREEN, AL 36401 Shipper, Per Agent, Per Permanent post office address of shipper		

Evergreen Technologies, Inc.
Packing List

12-Jun-00 13:21:08

Customer MID010

MIDESSA INDUSTRIAL VINYL CO **R002083**

Ship To:

MODERN PLATING CORP

701 S HANCOCK

FREEPORT, IL 61032

Order Number 0001858-00

PO Number: 0

Shipment Number: 4686

Line	Roll Number	Lot Number	Product Code
1	0403245	04022	DC4200AA168225
2	0403283	04022	DC4200AA168225
3	0403360	04022	DC4200AA168225
4	0403373	04022	DC4200AA168220
5	0403374	04022	DC4200AA168225

Appendix H2

Geocomposite Conformance Laboratory Results



Precision Geosynthetic Laboratories

December 18, 2000

Mr. Marty Cieslik
FOTH & VAN DYKE
 406 Science Drive
 Madison, WI 53711

Dear Mr. Cieslik:

RE: Modern Plating / 97M015

Thank you for consulting Precision Geosynthetic Laboratories for your material testing needs.

It should be noted that the test specimen and test sample used for this report was believed to be representative of the material produced under the designation herein stated. However, these results are indicative of only the specimens that were actually tested. The testing herein is based upon accepted industry practice as well as the test method listed. Precision Geosynthetic Laboratories neither accepts responsibility for nor makes claims to the final use and purpose of the material.

By accepting the data and results represented on this report, Client agrees to limit the liability of Precision Geosynthetic Laboratories from Client and all other parties for claims arising out of the use of this data to the cost for the respective test(s) represented in this report, and Client agrees to indemnify and hold harmless Precision Geosynthetic Laboratories from and against all liability in excess of the aforementioned limit.

The test data and all associated project information shall be held in confidence and disclosed to other parties only with the authorization of Client or Precision Geosynthetic Laboratories.

It is a company policy to keep the physical records of each job for 2 years since the receipt of the samples and keep the electronic file for 7 years. **Failed seam samples are kept for 7 years; good seam samples are disposed after 2 weeks and conformance samples are disposed after 1 month.** Should you need us to keep them longer, please advise us in writing.

If you have any questions or if we may be of further service, please do not hesitate to call at 800-522-4599.

Sincerely,

PRECISION GEOSYNTHETIC LABORATORIES

 Edith Fintor
 Quality Assurance

 Cora B. Queja
 Vice President

Enclosure: (Job No. 001631)

1160 North Gilbert Street, Anaheim, CA 92801, Tel # 714-520-9631, Fax # 714-520-9637



Precision Geosynthetic Laboratories

CLIENT: FOTH & VAN DYKE
PROJECT: Modern Plating / 97M015

VERIFICATION OF MATERIAL PROPERTIES
(PGL Job No. 001631)

MATERIAL DESCRIPTION: Double Sided Geocomposite - Final Cover

SAMPLED BY: FOTH & VAN DYKE

DATE RECEIVED: December 14, 2000

DATE REPORTED: December 18, 2000

SAMPLE IDENTIFICATIONS:

SAMPLE ID	PRECISION CONTROL NUMBER
Roll 0403366	68652

TESTS REQUIRED:

TEST METHOD	DESCRIPTION
<i>Geonet Portion:</i>	
ASTM D1505	Density
ASTM D1603	Carbon Black Content
ASTM D1238, <i>Cond. 190°C/2.16 kg</i>	Melt Flow Index
<i>Double Sided Geocomposite:</i>	
ASTM D413, <i>Method A</i>	Ply Bond Adhesion
ASTM D4716	Transmissivity

TEST CONDITIONS: The sample was conditioned for a minimum one hour in the laboratory at $22 \pm 2^{\circ}\text{C}$ ($71.6 \pm 3.6^{\circ}\text{F}$) and at $60 \pm 10\%$ relative humidity prior to test.

TEST RESULTS:

The test results are summarized in Table 1. The units in which the data are reported are included on the table.

PRECISION GEOSYNTHETIC LABORATORIES



Edith Pintor
Quality Assurance

Cora B. Queja
Vice President

1160 North Gilbert Street, Anaheim, CA 92801, Tel # 714-520-9631, Fax # 714-520-9637

TABLE 1.
MATERIAL PROPERTIES
CLIENT: FOTH & VAN DYKE
PROJECT: Modern Plating / 97M015

Date Received: 12/14/00
 Date Reported: 12/18/00
 Client Sample ID: Roll 0403366
 Material Description: Double Sided Geocomposite - Final Cover

QC'd By: *[Signature]*
 PGL Job No.: 001631
 PGL Control No.: 68652

SPECIMENS

		1	2	3	4	5	6	7	8	9	10	Avg.	Std. Dev.	Proj. Specs.	
METHOD DESCRIPTION															
<u>Geonet Portion Only:</u>															
ASTM D1505	Density (grams/ cm. ³)														
		0.9588	0.9588	0.9588									0.9588	0.0000	
ASTM D1238	Melt Flow Index (grams/ 10 minutes)														
		0.739	0.740	0.739									0.739	0.001	
ASTM D1603	Carbon Black Content (percent)														
		2.30	2.28										2.29	0.01	
<u>Geocomposite:</u>															
OT ASTM D4716	Transmissivity (x10 ⁻⁵ m ² /sec) (Normal Pressure: 14.5 psi; Gradient: 0.1; Seating Time: 1 hour)														
	MD	104.60	111.10										107.85	4.60	3x10 ⁻⁵
ASTM D413	Ply Bond Adhesion (lbs/ in.- width)														
Method A	MD	3.1	3.3	3.6	2.3	4.0						3.3	0.6	2.0	
	TD	4.0	5.1	5.3	5.8	4.3						4.9	0.7		

MD - MACHINE DIRECTION
 TD - TRANSVERSE DIRECTION



Precision Geosynthetic Laboratories

R002087

Appendix I

Rooting Zone Grain Size Analysis Giles Engineering Assoc., Inc.

PARTICLE SIZE DISTRIBUTION TEST REPORT

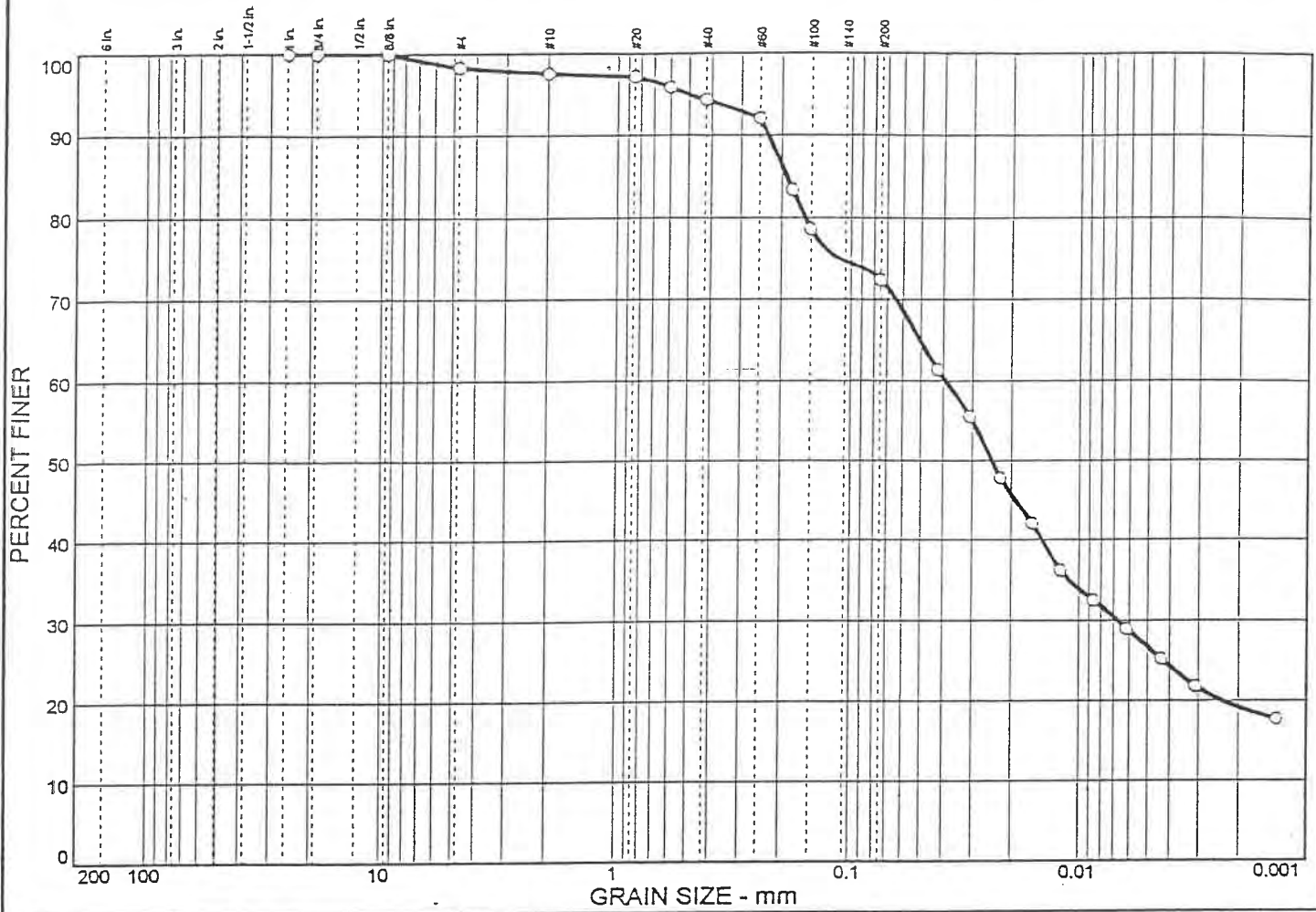

% COBBLES	% GRAVEL		% SAND			% FINES	
	CRS.	FINE	CRS.	MEDIUM	FINE	SILT	CLAY
0.0	0.0	1.7	0.7	3.2	22.0	45.8	26.6

LL	PL	D ₈₅	D ₆₀	D ₅₀	D ₃₀	D ₁₅	D ₁₀	C _c	C _u
		0.191	0.0395	0.0247	0.0068				

MATERIAL DESCRIPTION	USCS	AASHTO
⊙ Brown Silty Clay, little fine Sand, trace Gravel,	CL-ML	A-4(0)

Project No. 5M-0004006 Client: Foth & Van Dyke Project: Modern Plating Corporation Freeport, Illinois ⊙ Location: Civil Constructors Quarry	Remarks: ⊙ Sample No. 5MS-00025
--	------------------------------------

PARTICLE SIZE DISTRIBUTION TEST REPORT

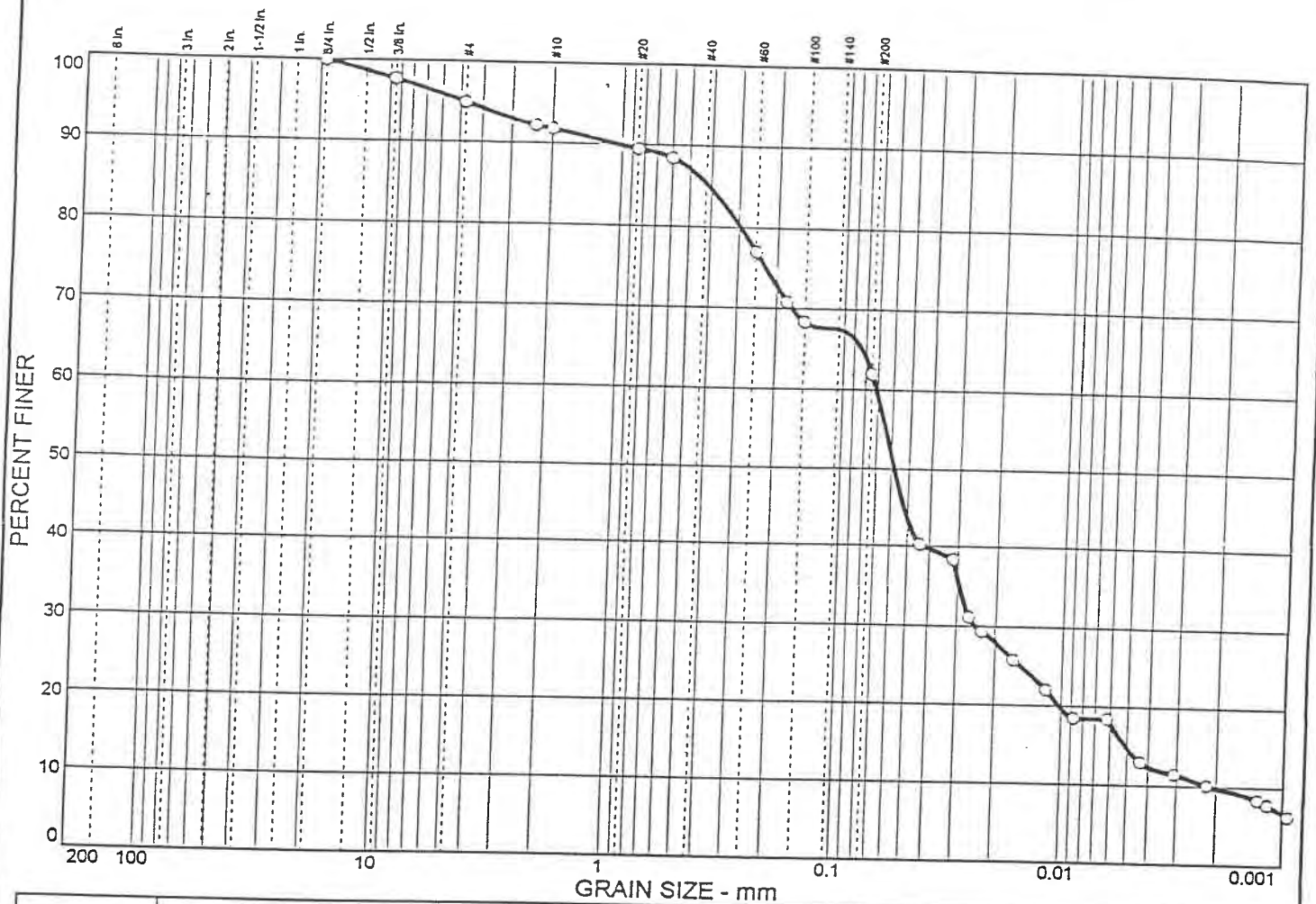

% COBBLES	% GRAVEL		% SAND			% FINES	
	CRS.	FINE	CRS.	MEDIUM	FINE	SILT	CLAY
0.0	0.0	5.1	3.1	6.4	23.5	47.2	14.7

LL	PL	D ₈₅	D ₆₀	D ₅₀	D ₃₀	D ₁₅	D ₁₀	C _c	C _u
29	16	0.413	0.0714	0.0582	0.0249	0.0051	0.0022	4.04	33.18

MATERIAL DESCRIPTION						USCS	AASHTO
Sandy lean clay						CL	A-6(5)

Project No. 5M-0004006 Client: Foth & Van Dyke
 Project: Modern Plating Corporation
 Freeport, Illinois
 Location: On-site, MPC-CIVIL-3-H

Remarks:
 Sample No. SMS-00104

Appendix J

Survey Plat for the CAMU Landfill Documentation

LEGEND

- PREVIOUSLY PLATTED LINE
- FRONT OF EXISTING CONCRETE SIDEWALK
- MODERN PLATING PROPERTY LINE
- EASEMENT LINE
- BUILDING LINE
- FENCE LINE
- PROPERTY CORNER FOUND (1IN DIA. IP)
- ⊕ CONTROL POINT

NOTES

1. SURVEY PERFORMED BY SPATIAL DATA SURVEYS, VERONA, WI, JULY, 2001.
2. BEARINGS FOR THIS SURVEY AND MAP ARE REFERENCED TO THE NORTH LINE OF SHAWNEE STREET, ASSUMED TO BEAR 500°00'00"E. HORIZONTAL DATUM IS REFERENCED TO SITE GRID BY FOTH AND VAN DYKE AND ASSOCIATES, MADISON, WI.
3. DRAWING NO. 2 ATTACHED WAS PREPARED BY FOTH AND VAN DYKE AND ASSOCIATES INC. THIS DRAWING SHOWS THE LOCATION OF THE AREAS FROM WHICH SOLID AND HAZARDOUS WASTES WERE REMOVED AND SUBSEQUENTLY PLACED IN THE CAMU.
4. THE CAMU CONTAINS THE REMEDIATION WASTES GENERATED DURING THE CLOSURE OF HAZARDOUS WASTE AND SOLID WASTE UNITS AT THE MODERN PLATING FACILITY IN ACCORDANCE WITH AN ILLINOIS EPA APPROVED CLOSURE PLAN (LOG NO. C-259-M-8).
5. THE WASTE MATERIALS CONTAINED IN THE CAMU ARE CONSIDERED RCRA HAZARDOUS WASTES. THEY INCLUDE ELECTROPLATING SLUDGES (F006), WASTES WITH TRICHLOROETHYLENE (F002) AND WASTES CONTAINING CADMIUM, CHROMIUM, AND CYANIDE.
6. ANY FILL REMOVED FROM THE CAMU DURING FUTURE ACTIVITIES MUST BE MANAGED AS A HAZARDOUS WASTE IN ACCORDANCE WITH 35 ILL. ADM. CODE SUBTITLE G: WASTE DISPOSAL.
7. THE USE OF THIS AREA IS RESTRICTED.
8. A SURVEY PLAT AND RECORD OF THE TYPE, LOCATION AND QUALITY OF WASTE MATERIALS IN THE CAMU HAVE BEEN FILED WITH IPEA, THE COUNTY, AND ANY LOCAL ZONING AUTHORITY WITH JURISDICTION OVER LOCAL LAND USE.

LEGAL DESCRIPTION

A PARCEL OF LAND LOCATED IN OUTLOT 2, GUND'S SECOND ADDITION, CITY OF FREEPORT, STEPHENSON COUNTY, ILLINOIS, MORE PARTICULARLY DESCRIBED AS FOLLOWS:

COMMENCING AT THE NORTHWEST CORNER OF SAID OUTLOT 2;

THENCE ALONG THE NORTH LINE OF SAID OUTLOT 2, N 89°50'48" E, 403.99';

THENCE NORMAL TO THE NORTH LINE OF SAID OUTLOT 2, S 00°09'12" E, 25.28 FEET TO A METAL FENCE POST SET IN CONCRETE, THE POINT OF BEGINNING OF THIS DESCRIPTION;

THENCE S 89°19'22" W, 306.75 FEET TO A METAL FENCE POST SET IN CONCRETE;

THENCE S 82°35'44" W, 10.02 FEET TO A METAL FENCE POST SET IN CONCRETE;

THENCE S 64°52'48" W, 9.85 FEET TO A METAL FENCE POST SET IN CONCRETE;

THENCE S 49°01'34" W, 9.96 FEET TO A METAL FENCE POST SET IN CONCRETE;

THENCE S 32°37'16" W, 19.94 FEET TO A METAL FENCE POST SET IN CONCRETE;

THENCE S 25°05'47" W, 9.98 FEET TO A METAL FENCE POST SET IN CONCRETE;

THENCE S 16°36'36" W, 10.45 FEET TO A METAL FENCE POST SET IN CONCRETE;

THENCE S 11°04'29" W, 10.19 FEET TO A METAL FENCE POST SET IN CONCRETE;

THENCE S 06°06'25" W, 10.69 FEET TO A METAL FENCE POST SET IN CONCRETE;

THENCE S 04°28'31" W, 20.44 FEET TO A METAL FENCE POST SET IN CONCRETE;

THENCE S 86°25'09" E, 44.47 FEET TO A METAL FENCE POST SET IN CONCRETE;

THENCE S 23°33'39" E, 78.70 FEET TO A METAL FENCE POST SET IN CONCRETE;

THENCE S 89°48'05" E, 24.85 FEET TO A CORNER OF A BUILDING;

THENCE ALONG SAID BUILDING, N 89°48'36" E, 89.50 FEET TO A CORNER OF SAID BUILDING;

THENCE ALONG SAID BUILDING, S 00°04'44" W, 57.83 FEET TO A CORNER OF SAID BUILDING;

THENCE ALONG SAID BUILDING, S 89°50'48" E, 61.00 FEET TO A CORNER OF SAID BUILDING;

THENCE N 89°51'11" E, 103.11 FEET TO A METAL FENCE POST SET IN CONCRETE;

THENCE N 00°23'29" E, 224.92 FEET TO THE POINT OF BEGINNING.

SAID PARCEL CONTAINING 62,904 SQUARE FEET OR 1.444 ACRES.



SURVEYOR'S CERTIFICATE:

I, JAMES D. PREHN, REGISTERED ILLINOIS LAND SURVEYOR, NO. 035-002930, HEREBY CERTIFY THAT I HAVE SURVEYED THE FOREGOING BASED ON A FOUND 1-INCH IRON PIPE AND EXISTING CONCRETE SIDEWALK ALONG SHAWNEE STREET AND RECORD INFORMATION AS SHOWN ON THE PLAT'S OF GUND'S SECOND ADDITION AND ARCADE ADDITION, CITY OF FREEPORT, STEPHENSON COUNTY, ILLINOIS, TO THE BEST OF MY KNOWLEDGE, UNDERSTANDING, AND BELIEF.

James D. Prehn 17 July 01
 JAMES D. PREHN DATE
 035-002930

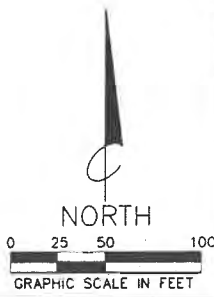

Rev.	Description	By	Date
△			
Plat of Survey CAMU Legal Description & Survey Map Modern Plating Property PIN 18-14-32-402-019 Part of OL 2, Gund's Second Addition City of Freeport, Stephenson County, Illinois			Dwn: JDP Date: 17 July 2001 Spatial Data Surveys, 580 Arthur Street Verona, WI 53593 608-845-2048
Drawing No. SDS01013-1		Sheet No. 1 of 1	

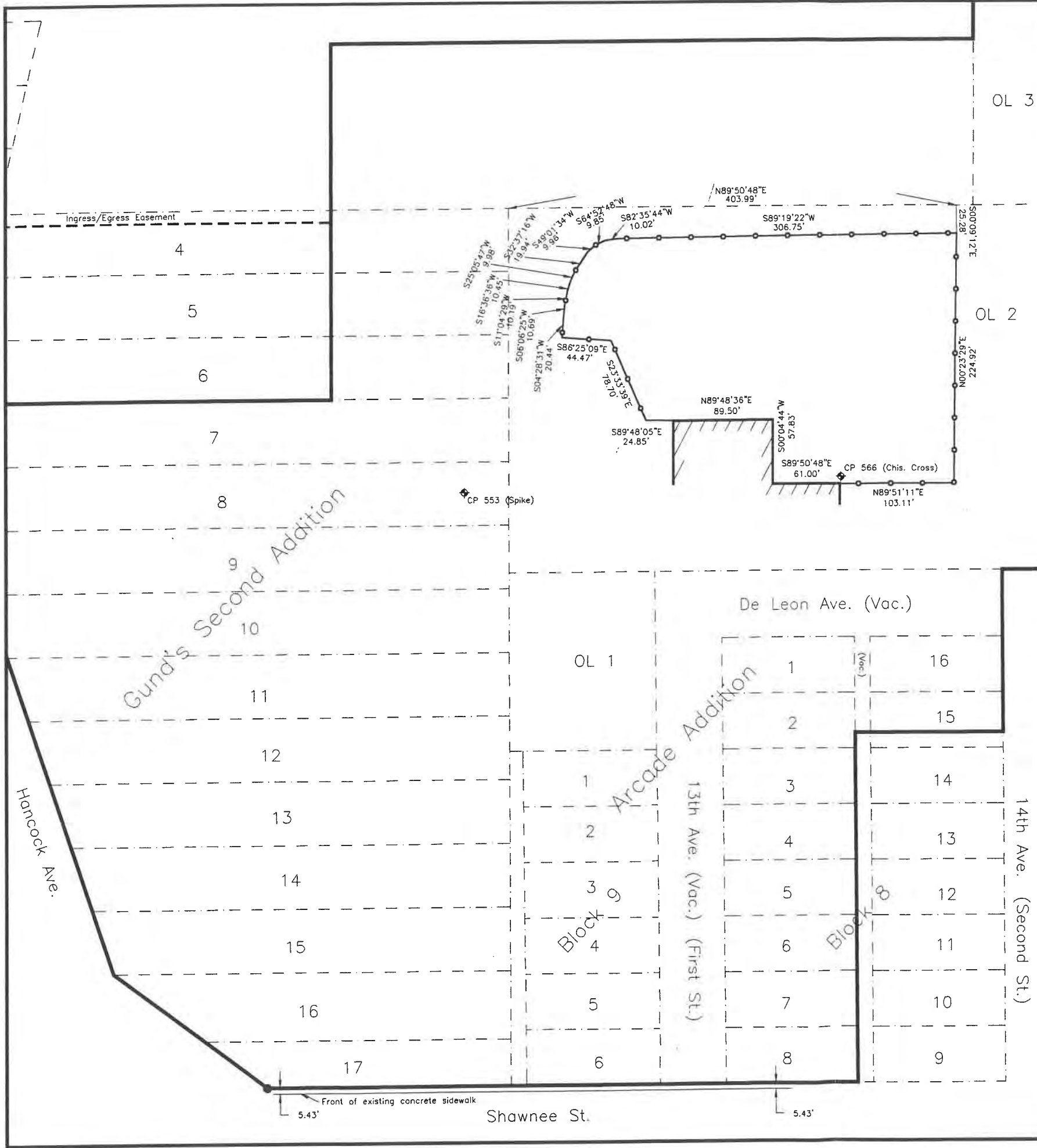

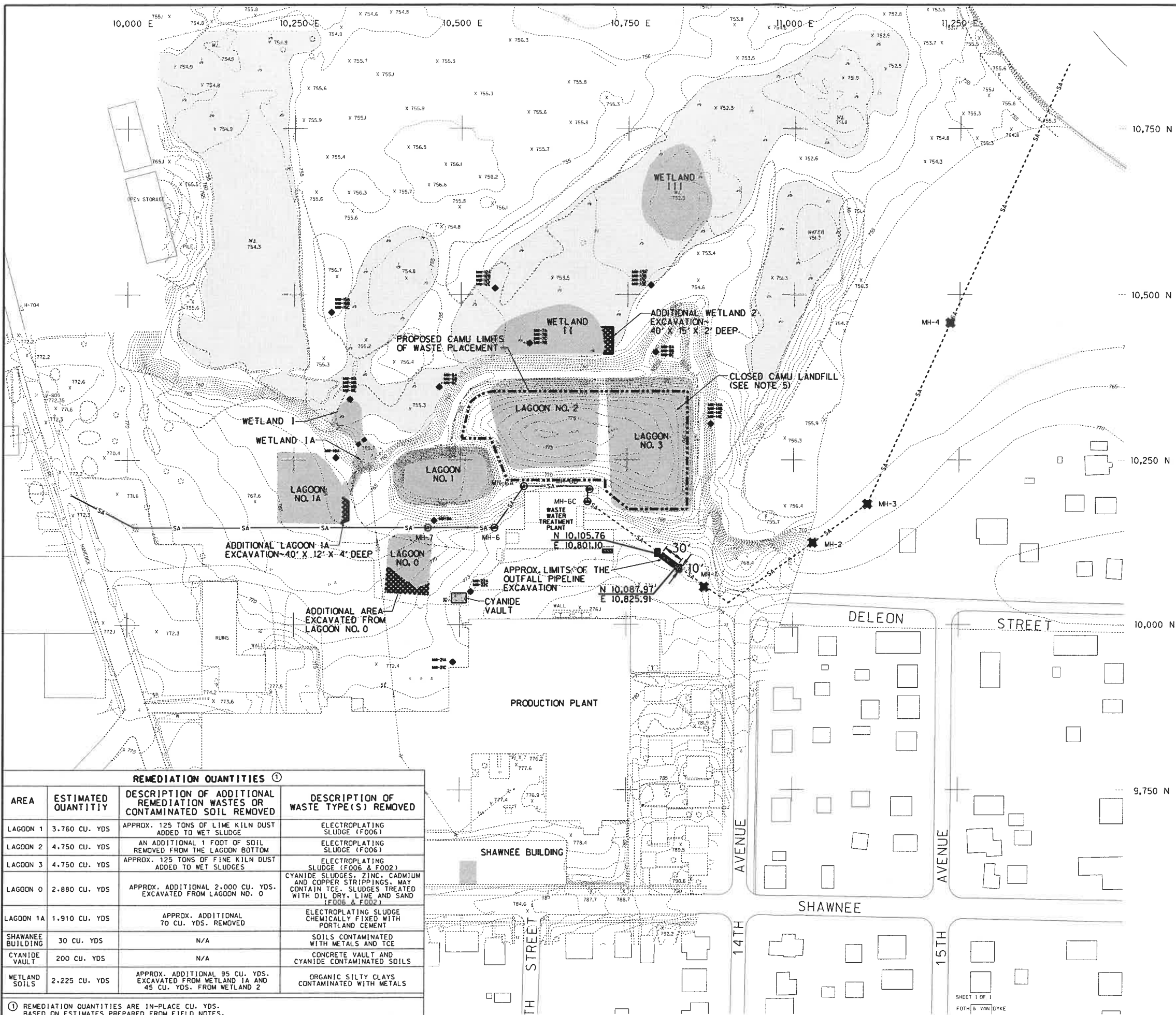

LEGEND

- EXISTING BUILDING
- EXISTING GROUND CONTOUR
- EXISTING SPOT ELEVATION
- DEPRESSION
- TREES AND / OR BRUSH
- EXISTING ROADWAY
- EXISTING TRAIL
- MARSH/SWAMP SYMBOL
- WATER BOUNDARY
- EXISTING FENCE
- ACTIVE DISCHARGE SANITARY SEWER PIPELINE
- ABANDONED OUTFALL PIPELINE
- AREA EXCAVATED 10' (WIDTH AT EXCAVATION BASE) X 30' (LENGTH) X 7' (DEPTH)
- PIPELINE PLUG NOT IN A MANHOLE
- SPOT LOCATIONS (X, Y)
- AREA EXCAVATED TO REMOVE CHROMATE RINSE WATER CONTAMINATED SOILS
- PIPELINE PLUGGED AND MANHOLE FILLED WITH SOIL
- MONITORING WELL NUMBER AND LOCATION
- CONTROL MONUMENT NUMBER AND LOCATION
- APPROXIMATE BOUNDARY OF EXISTING SLUDGE STORAGE AREA
- PROPOSED CAMU LIMITS OF WASTE PLACEMENT
- EXISTING WETLAND AREA
- STORM DRAIN
- AREAS REMEDIATED (REFER TO SCHEDULE ON THIS DRAWING FOR ESTIMATED QUANTITIES)

- NOTES:**
- SITE LOCATION: SE 1/4 OF SECTION 32, T27N, R8E, STEPHENSON COUNTY, ILLINOIS
 - TOPOGRAPHICAL BASE MAP PREPARED BY AERO-METRIC ENGINEERING, SHEBOYGAN, WISCONSIN. DATE OF PHOTOGRAPHY: NOVEMBER 28, 1986.
 - ELEVATIONS BASED ON MEAN SEA LEVEL DATUM. CONTOUR INTERVAL IS ONE FOOT. BENCH MARK IS LOCATED ON THE N.W. CORNER OF THE PUMP STATION CONCRETE SLAB, COORDINATES N 10046.1 E 10491.0, AT ELEVATION 773.82 FEET.
 - 500 YEAR FLOOD BOUNDARY TAKEN FROM "NOVEMBER 1976 FLOOD INSURANCE STUDY" BY U.S. DEPARTMENT OF HOUSING & URBAN DEVELOPMENT, FEDERAL INSURANCE ADMINISTRATION.
 - SEE DRAWING NO.1 CAMU LEGAL DESCRIPTION AND SURVEY MAP FOR DETAILED LEGAL DESCRIPTION OF THE CAMU.

REMEDATION QUANTITIES ①			
AREA	ESTIMATED QUANTITY	DESCRIPTION OF ADDITIONAL REMEDIATION WASTES OR CONTAMINATED SOIL REMOVED	DESCRIPTION OF WASTE TYPE(S) REMOVED
LAGOON 1	3.760 CU. YDS	APPROX. 125 TONS OF LIME KILN DUST ADDED TO WET SLUDGE	ELECTROPLATING SLUDGE (F006)
LAGOON 2	4.750 CU. YDS	AN ADDITIONAL 1 FOOT OF SOIL REMOVED FROM THE LAGOON BOTTOM	ELECTROPLATING SLUDGE (F006)
LAGOON 3	4.750 CU. YDS	APPROX. 125 TONS OF FINE KILN DUST ADDED TO WET SLUDGES	ELECTROPLATING SLUDGE (F006 & F002)
LAGOON 0	2.880 CU. YDS	APPROX. ADDITIONAL 2,000 CU. YDS. EXCAVATED FROM LAGOON NO. 0	CYANIDE SLUDGES, ZINC, CADMIUM AND COPPER STRIPPINGS. MAY CONTAIN TCE. SLUDGES TREATED WITH OIL DRY, LIME AND SAND (F006 & F002)
LAGOON 1A	1.910 CU. YDS	APPROX. ADDITIONAL 70 CU. YDS. REMOVED	ELECTROPLATING SLUDGE CHEMICALLY FIXED WITH PORTLAND CEMENT
SHAWNEE BUILDING	30 CU. YDS	N/A	SOILS CONTAMINATED WITH METALS AND TCE
CYANIDE VAULT	200 CU. YDS	N/A	CONCRETE VAULT AND CYANIDE CONTAMINATED SOILS
WETLAND SOILS	2,225 CU. YDS	APPROX. ADDITIONAL 95 CU. YDS. EXCAVATED FROM WETLAND 1A AND 45 CU. YDS. FROM WETLAND 2	ORGANIC SILTY CLAYS CONTAMINATED WITH METALS

① REMEDIATION QUANTITIES ARE IN-PLACE CU. YDS. BASED ON ESTIMATES PREPARED FROM FIELD NOTES.

MODERN PLATING CORPORATION

DRAWING NO. 2

EXTENT OF AREAS REMEDIATED

Scale: Date: JULY, 2001

Prepared By: Foth & Van Dyke By: JOW 97M015

Appendix K

Soil Isoconcentration Contour Maps - Shawnee Building and Wetlands

Soil Arsenic Concentrations (mg/kg) 0.5 - 1.5 Feet

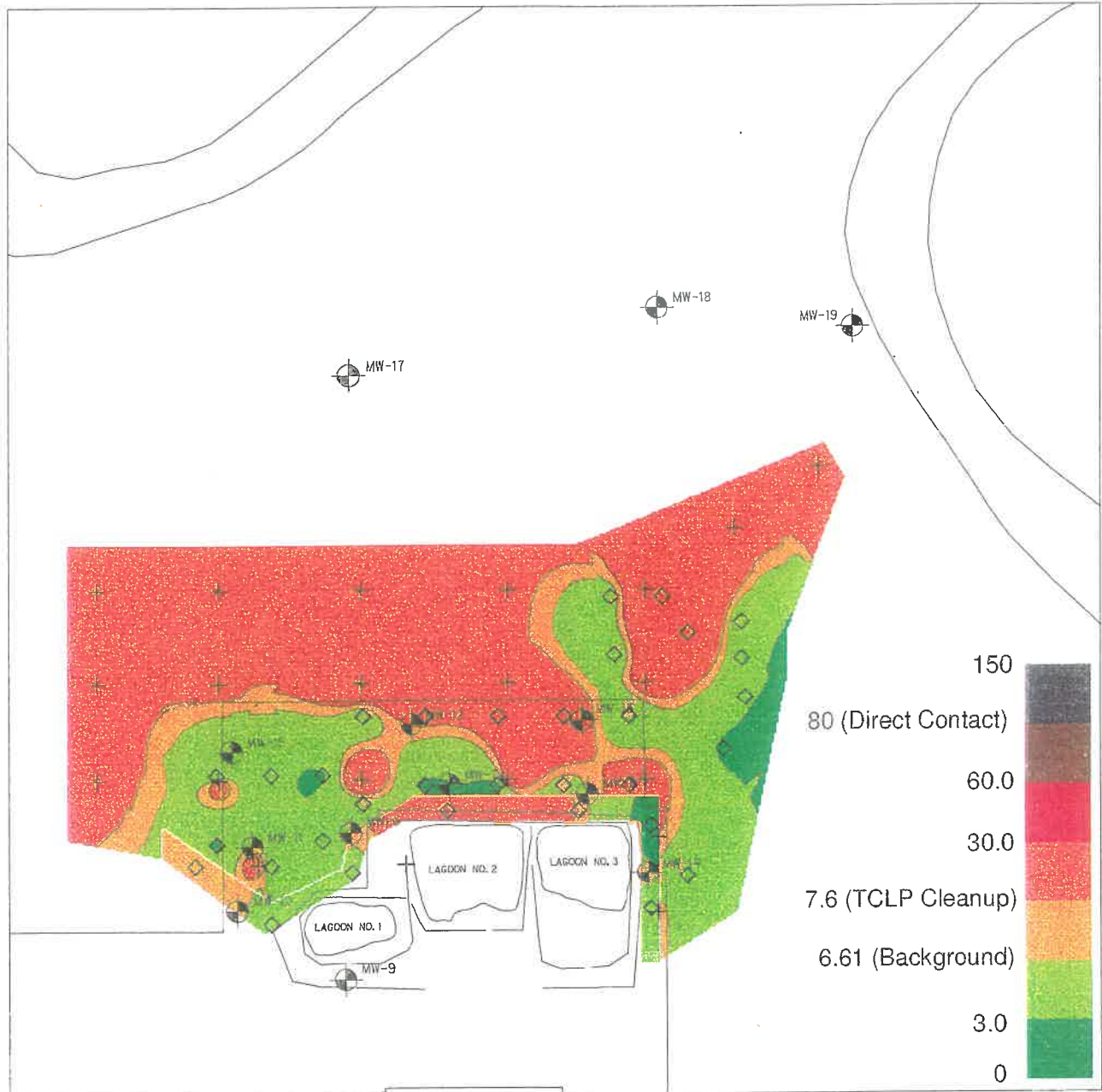

+ 1991 Soil Sample

◇ 1994 Soil Sample



Feet

Soil Arsenic Concentrations (mg/kg) 2.5 - 3.5 Feet

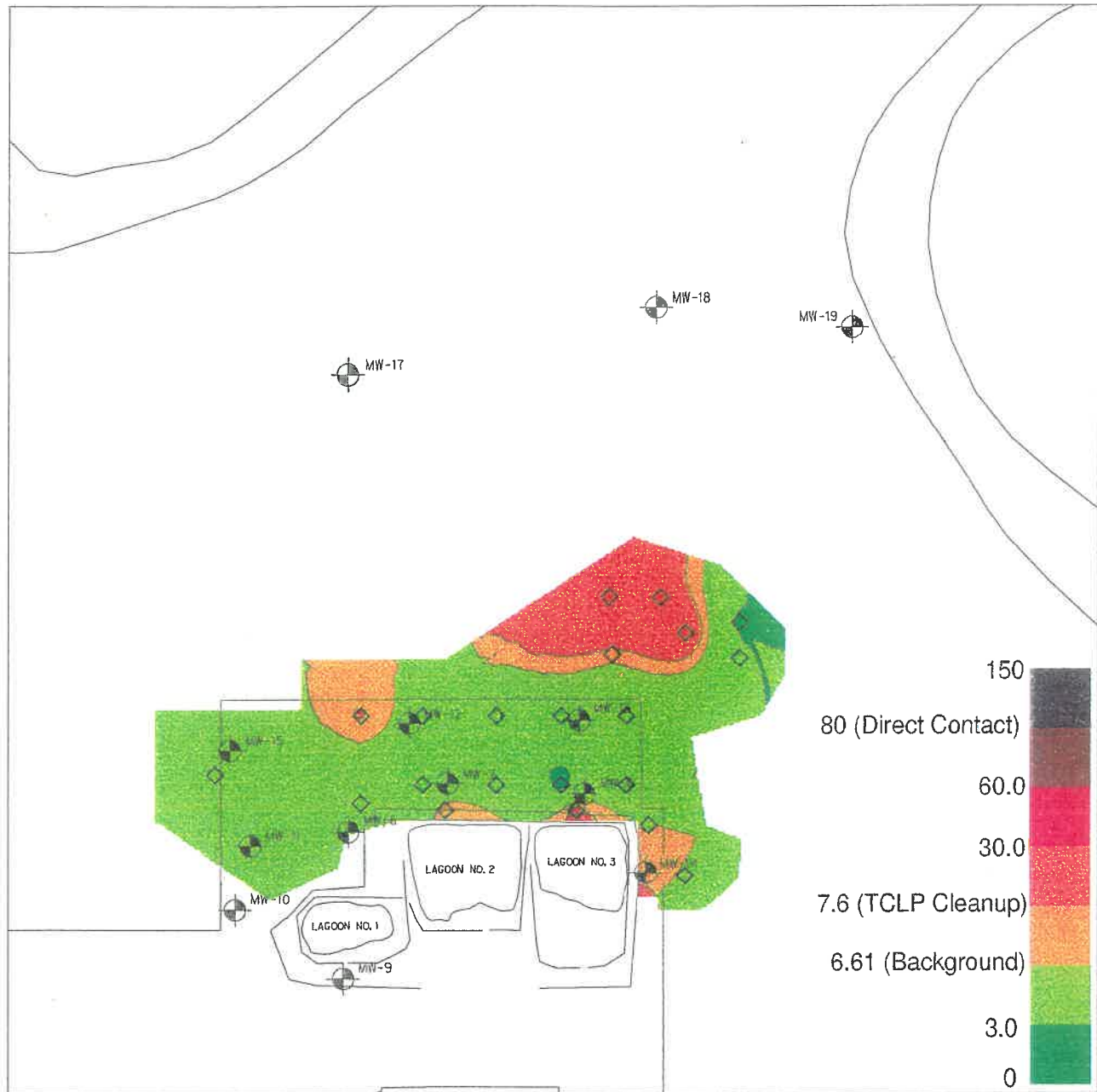

◇ 1994 Soil Sample

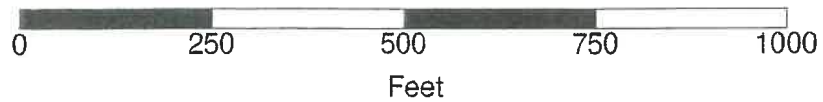

Soil Arsenic Concentrations (mg/kg) 4.5 - 5.5 Feet

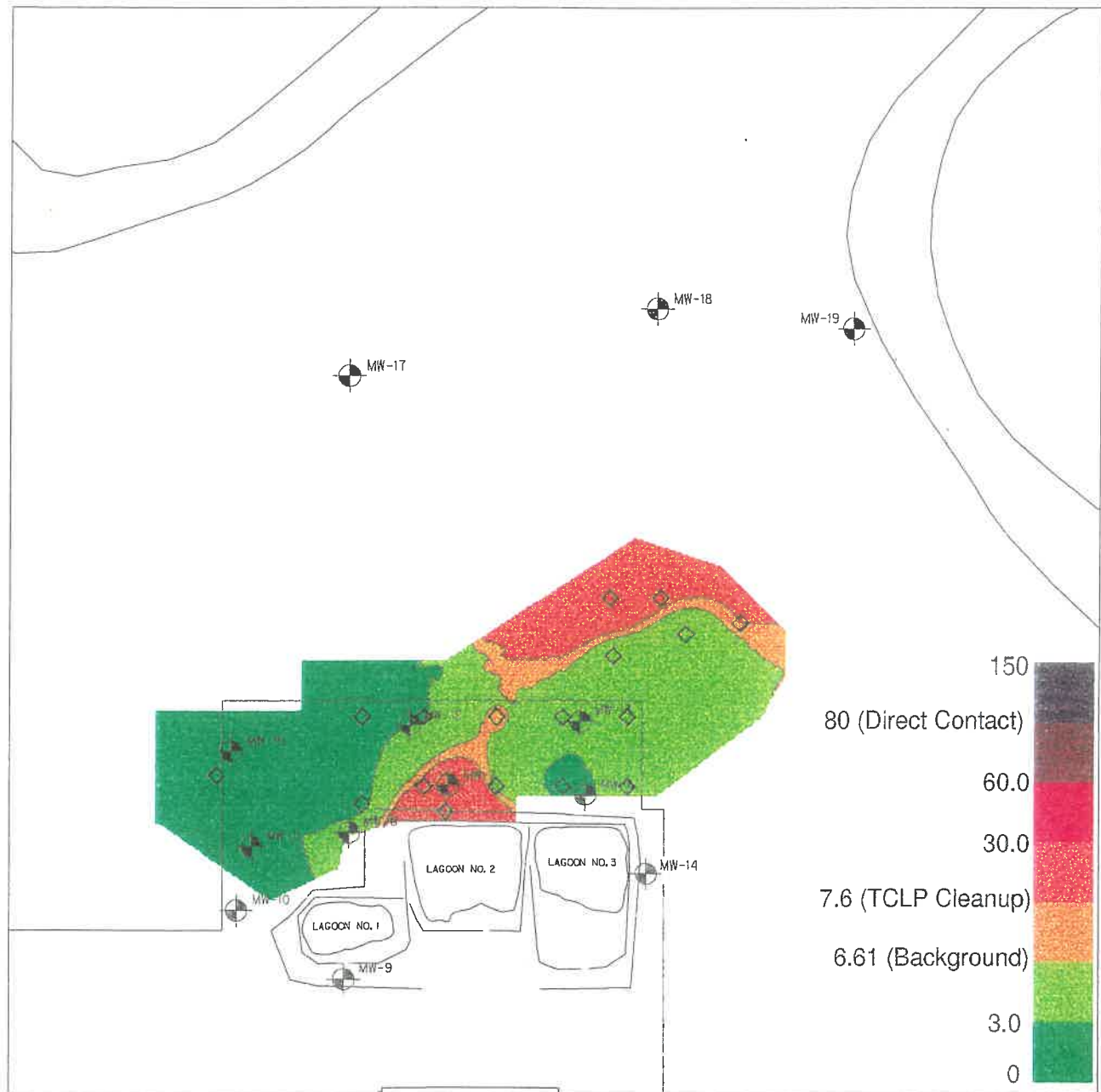

◇ 1994 Soil Sample

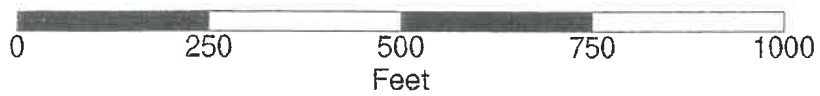

Soil Cadmium Concentrations (mg/kg) 0.5 - 1.5 Feet

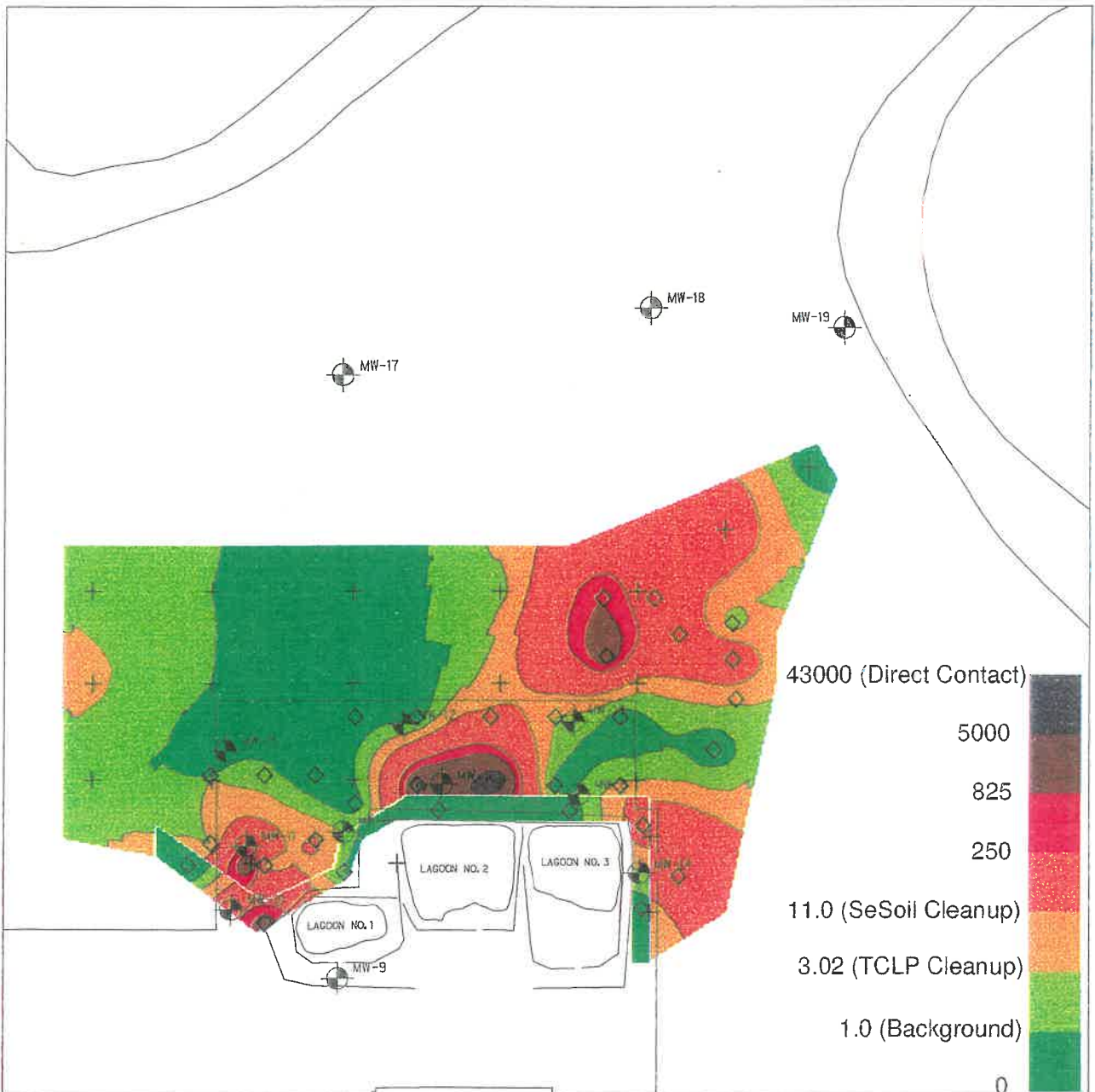

+ 1991 Soil Sample

◇ 1994 Soil Sample



Soil Cadmium Concentrations (mg/kg) 2.5 - 3.5 Feet

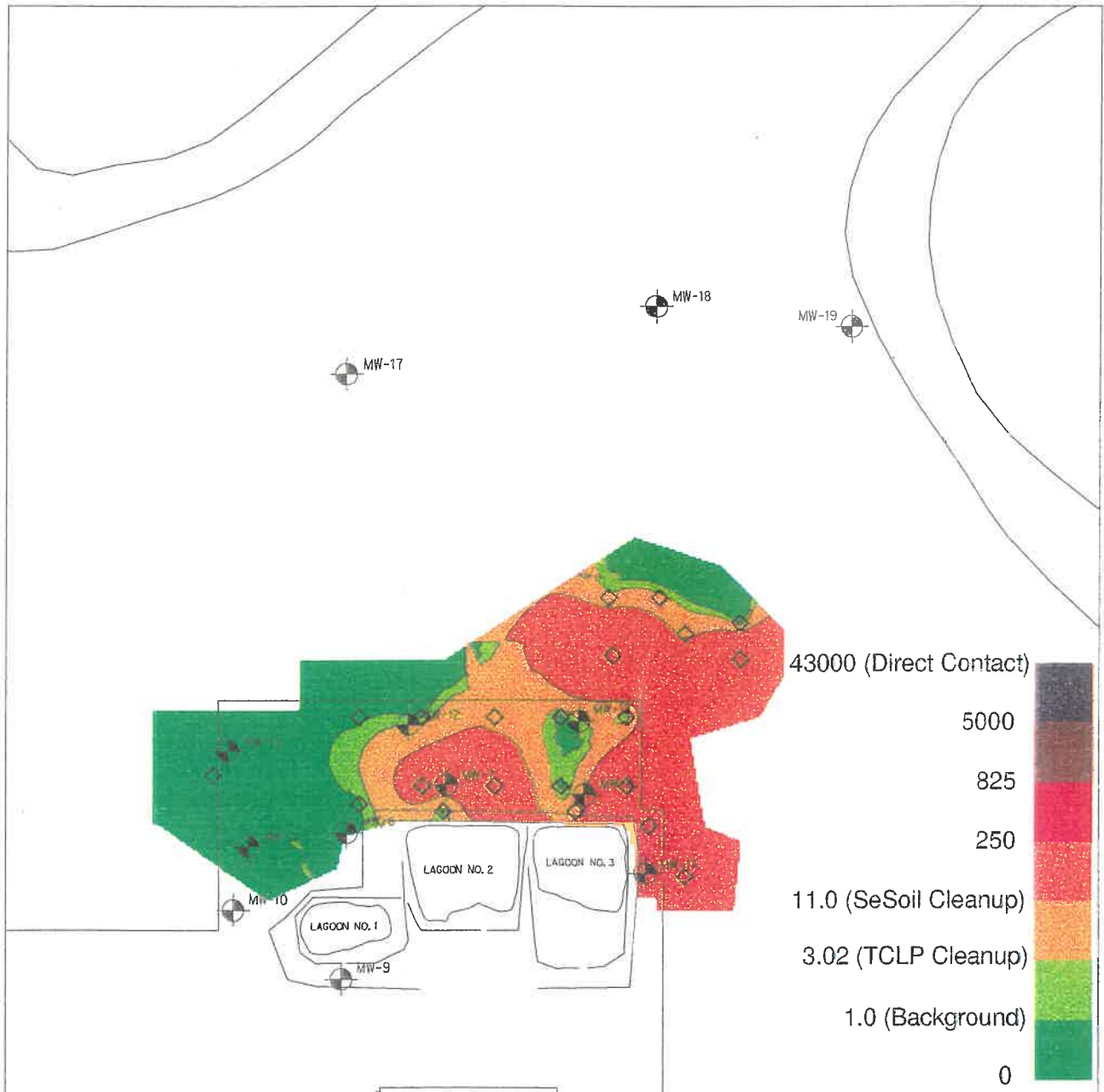

◇ 1994 Soil Sample



Soil Cadmium Concentrations (mg/kg) 4.5 - 5.5 Feet

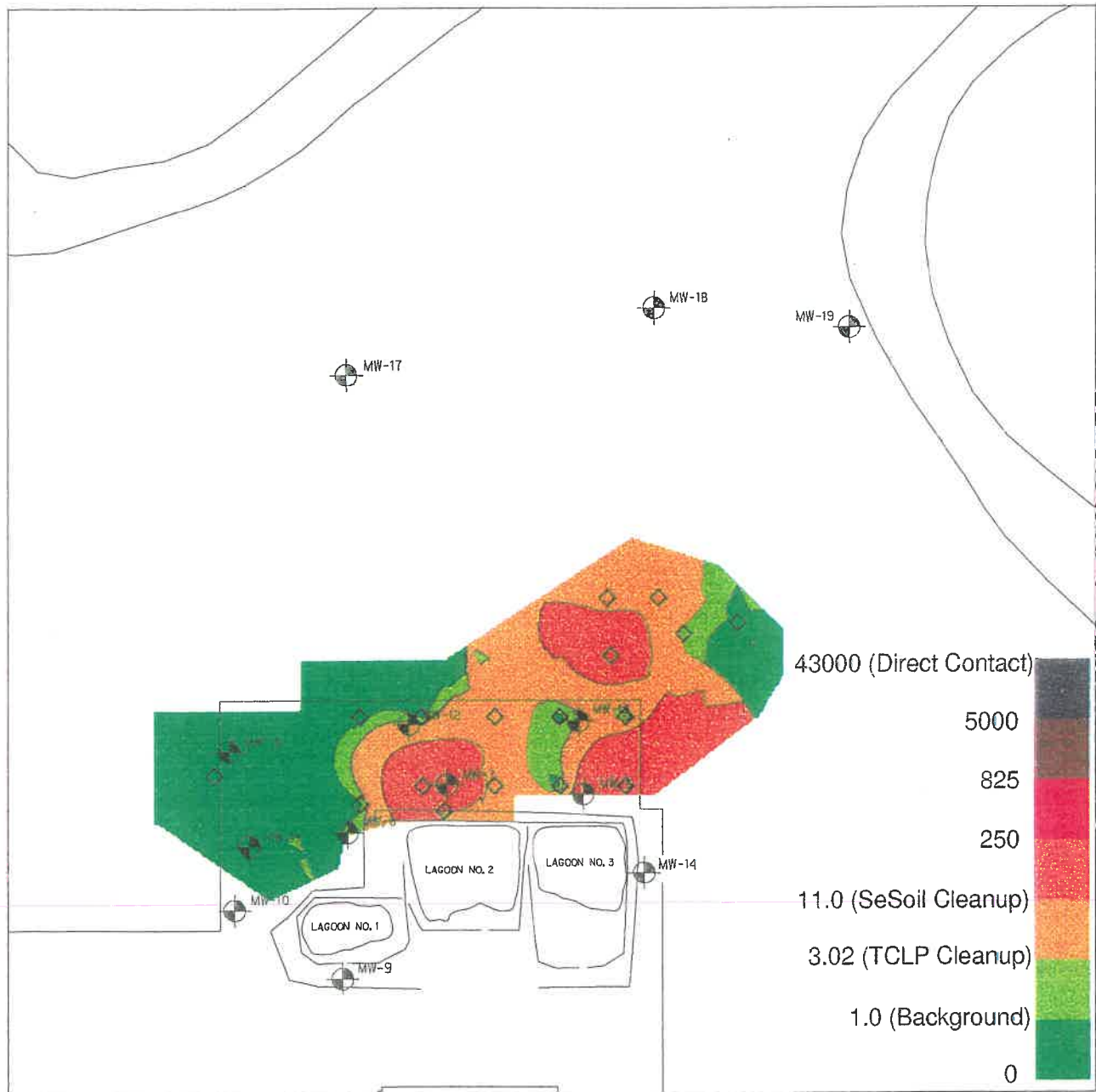

◇ 1994 Soil Sample



Soil Chromium Concentrations (mg/kg) 0.5 - 1.5 Feet

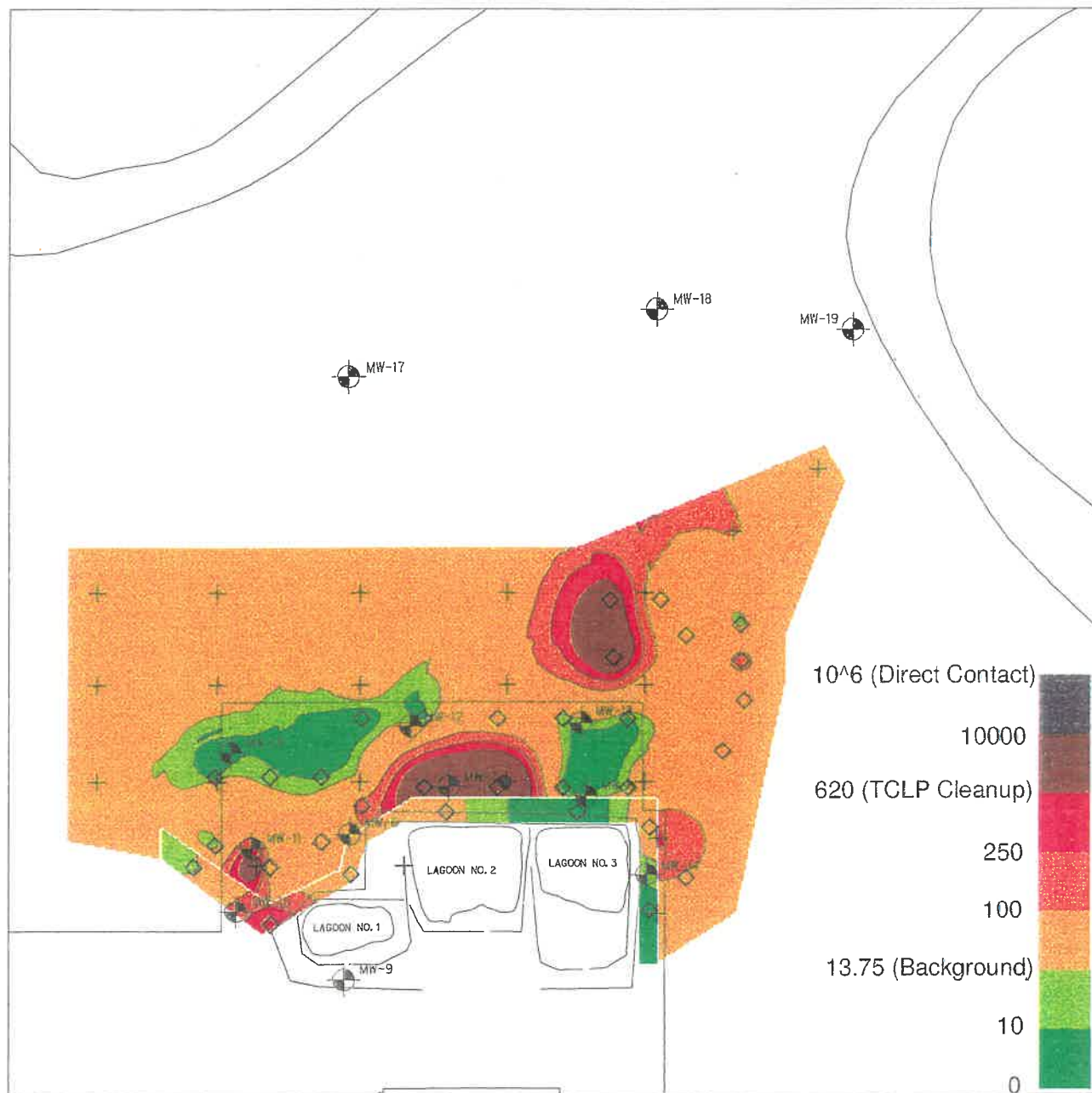

+ 1991 Soil Sample
◇ 1994 Soil Sample



Soil Chromium Concentrations (mg/kg) 2.5 - 3.5 Feet

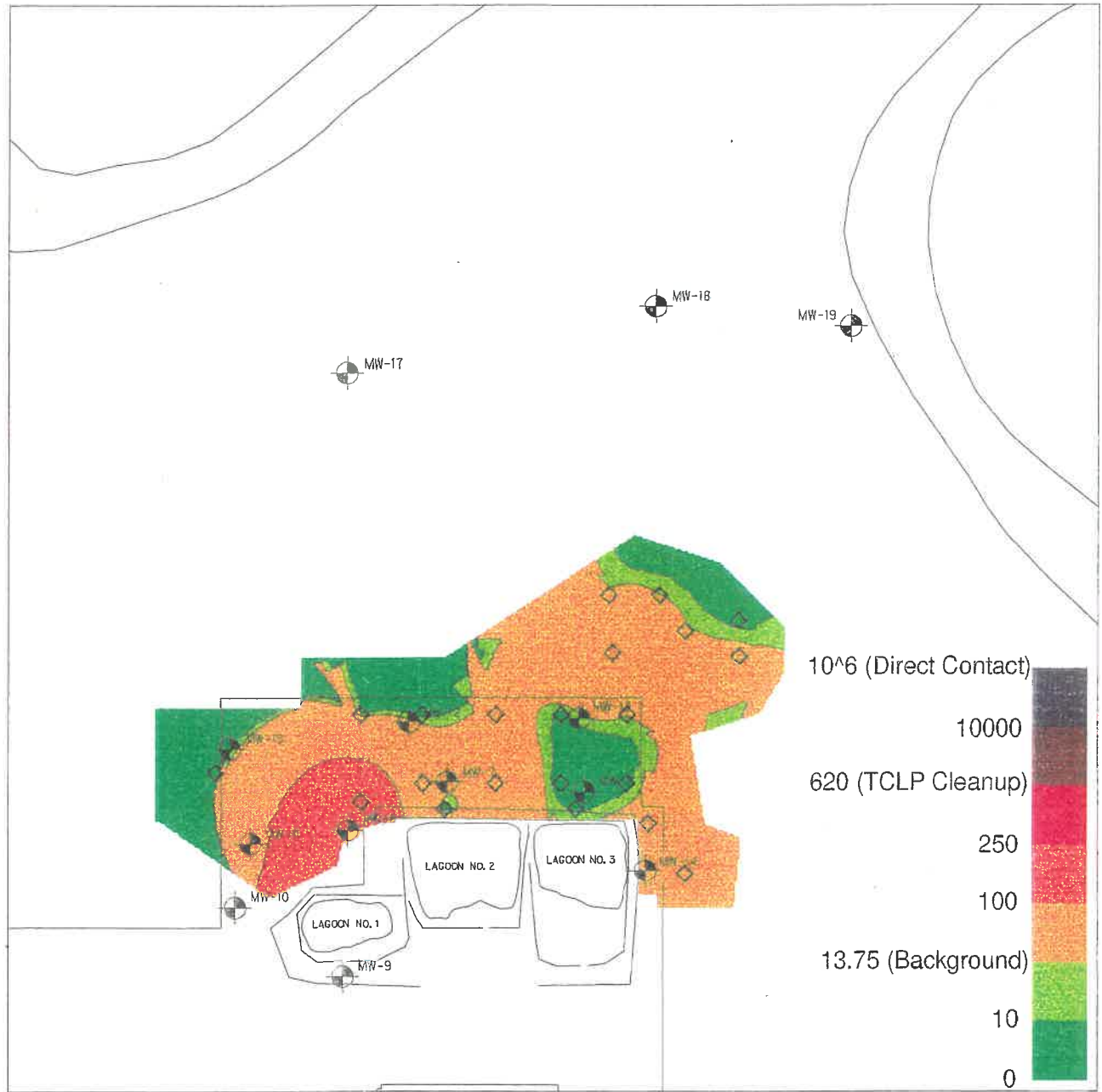

◇ 1994 Soil Sample



Soil Chromium Concentrations (mg/kg) 4.5 - 5.5 Feet

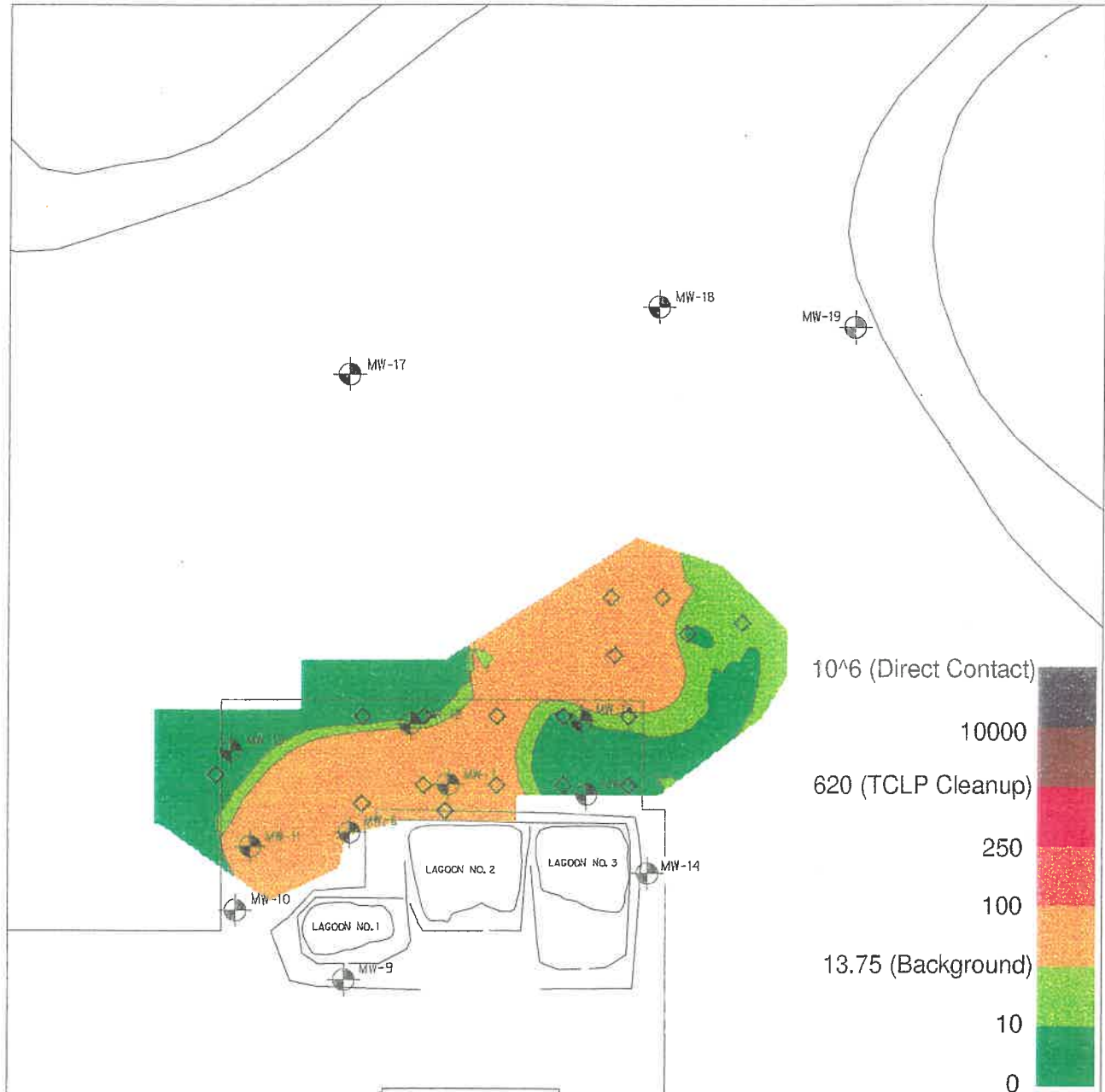

Soil Cyanide Concentrations (mg/kg) 0.5 - 1.5 Feet

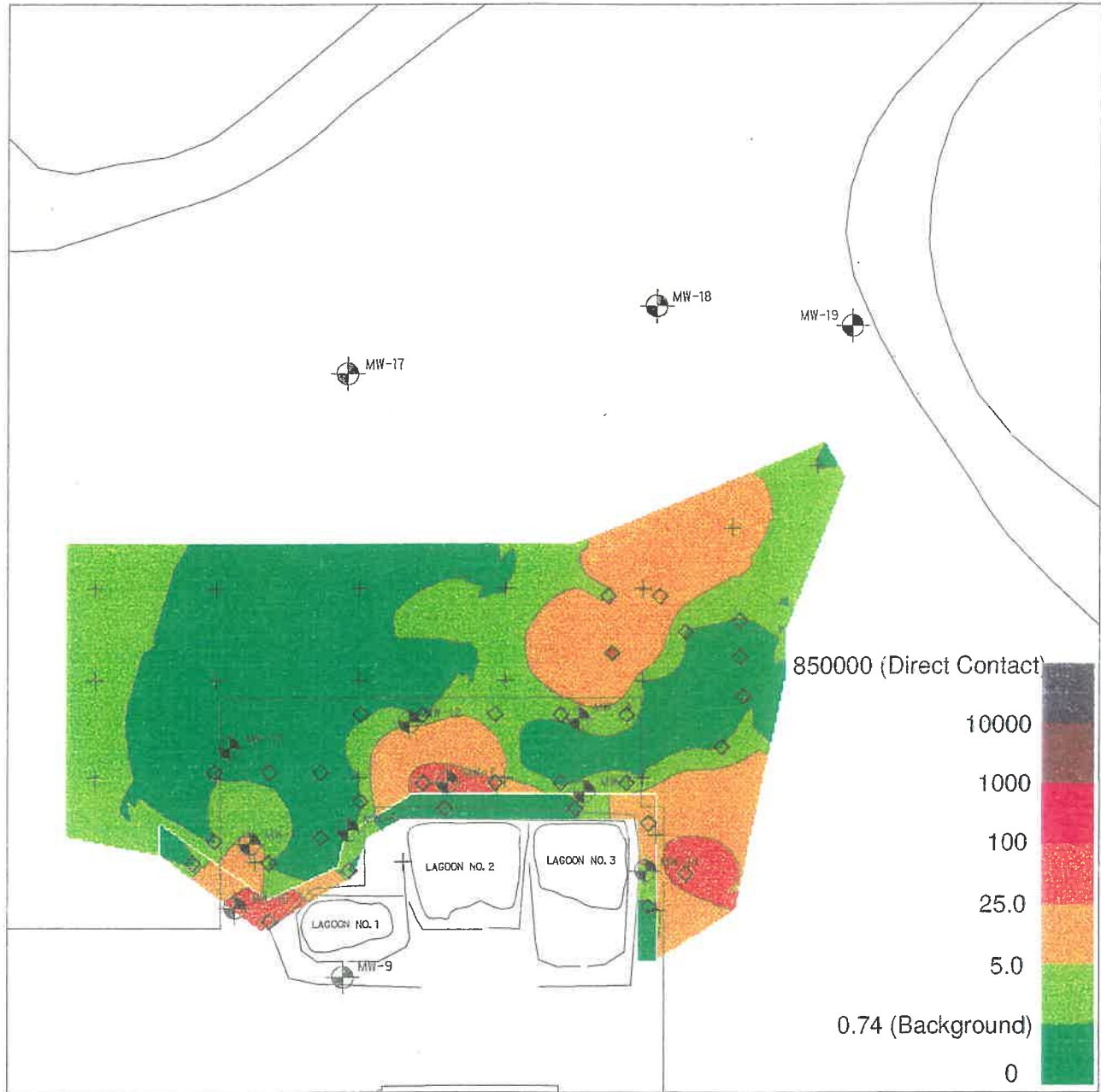

+ 1991 Soil Sample
◇ 1994 Soil Sample



Soil Cyanide Concentrations (mg/kg) 2.5 - 3.5 Feet



◇ 1994 Soil Sample



Soil Cyanide Concentrations (mg/kg) 4.5 - 5.5 Feet

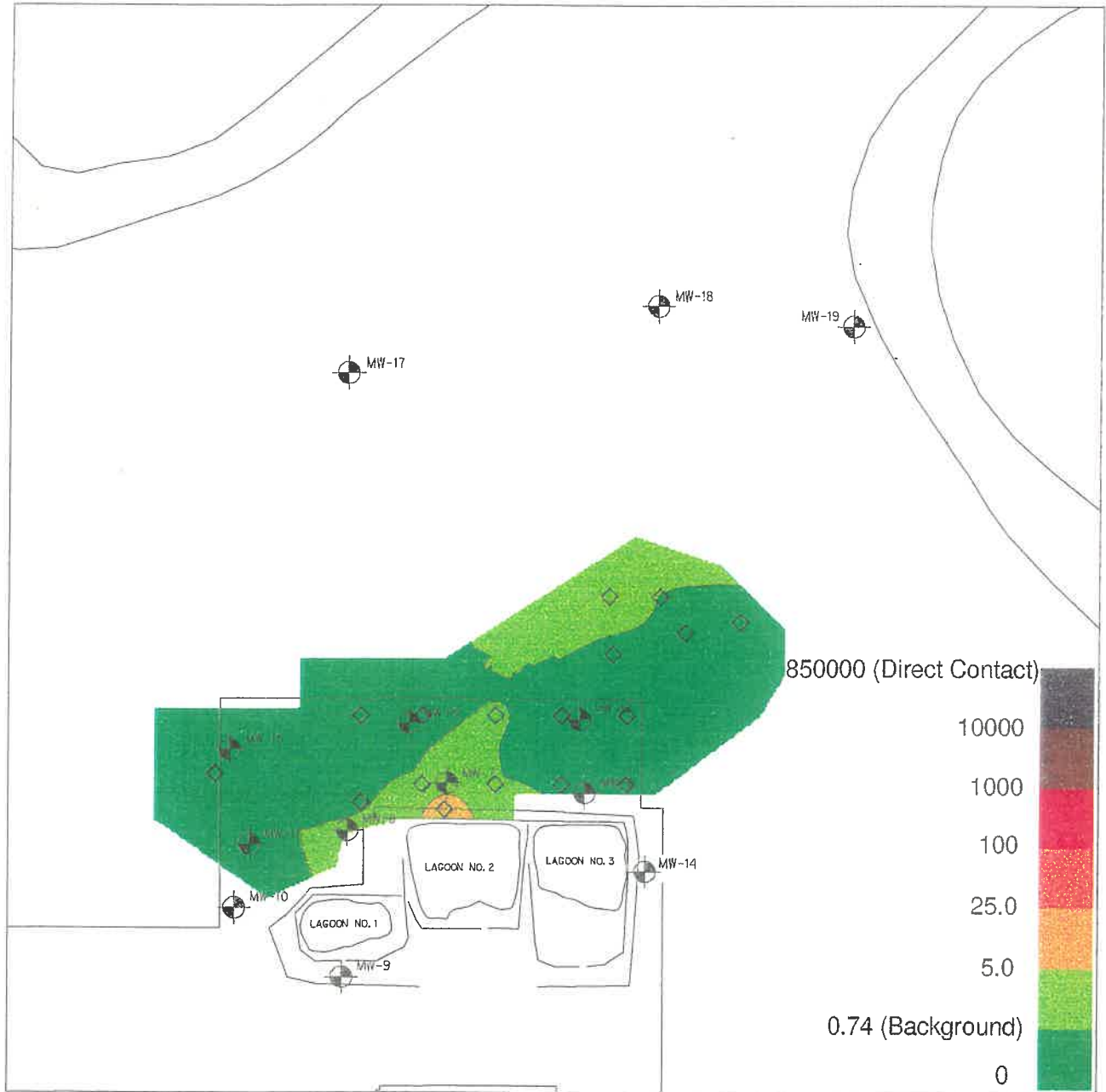

Soil Lead Concentrations (mg/kg) 0.5 - 1.5 Feet

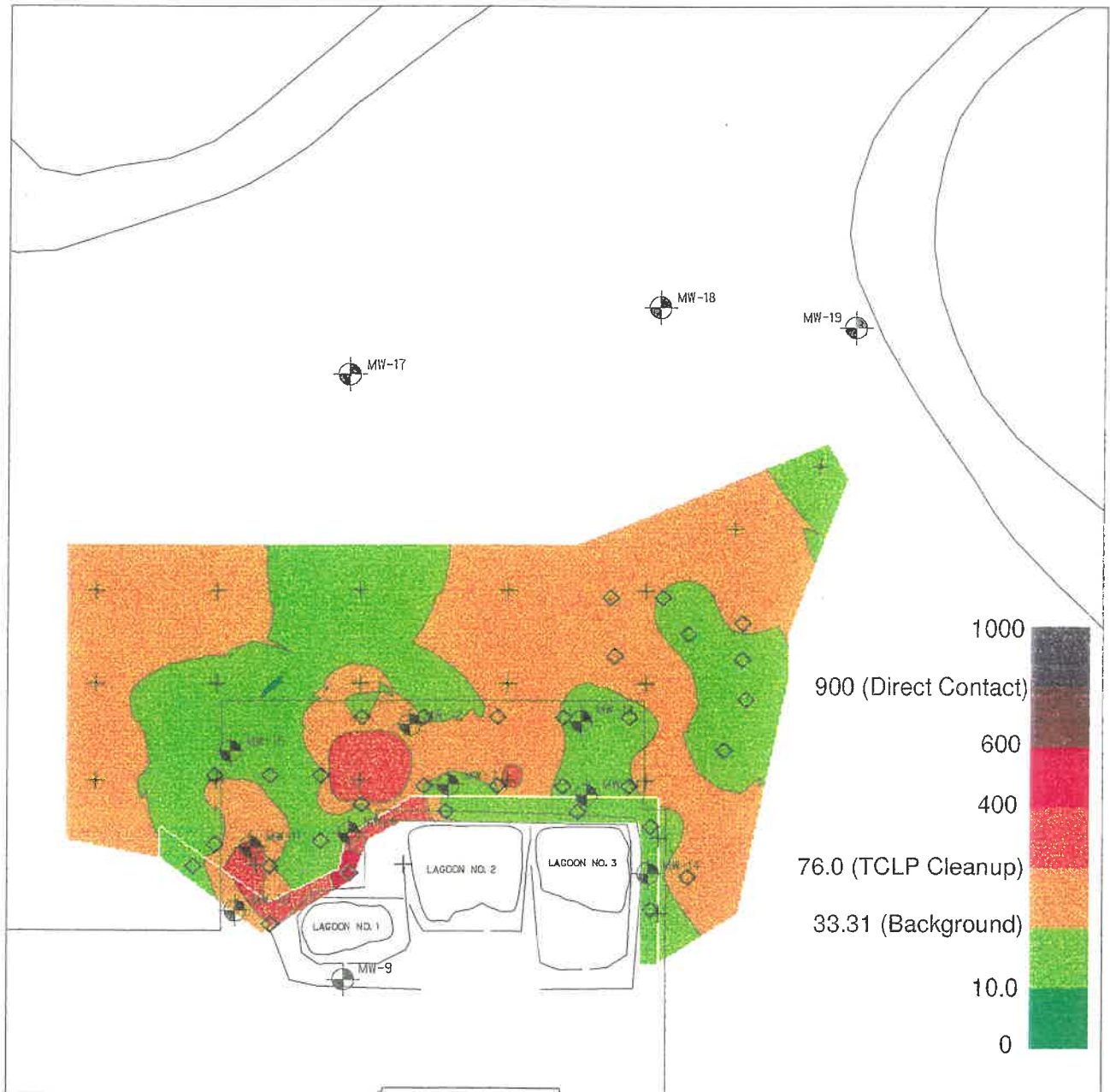

- + 1991 Soil Sample
- ◇ 1994 Soil Sample



Soil Lead Concentrations (mg/kg) 2.5 - 3.5 Feet

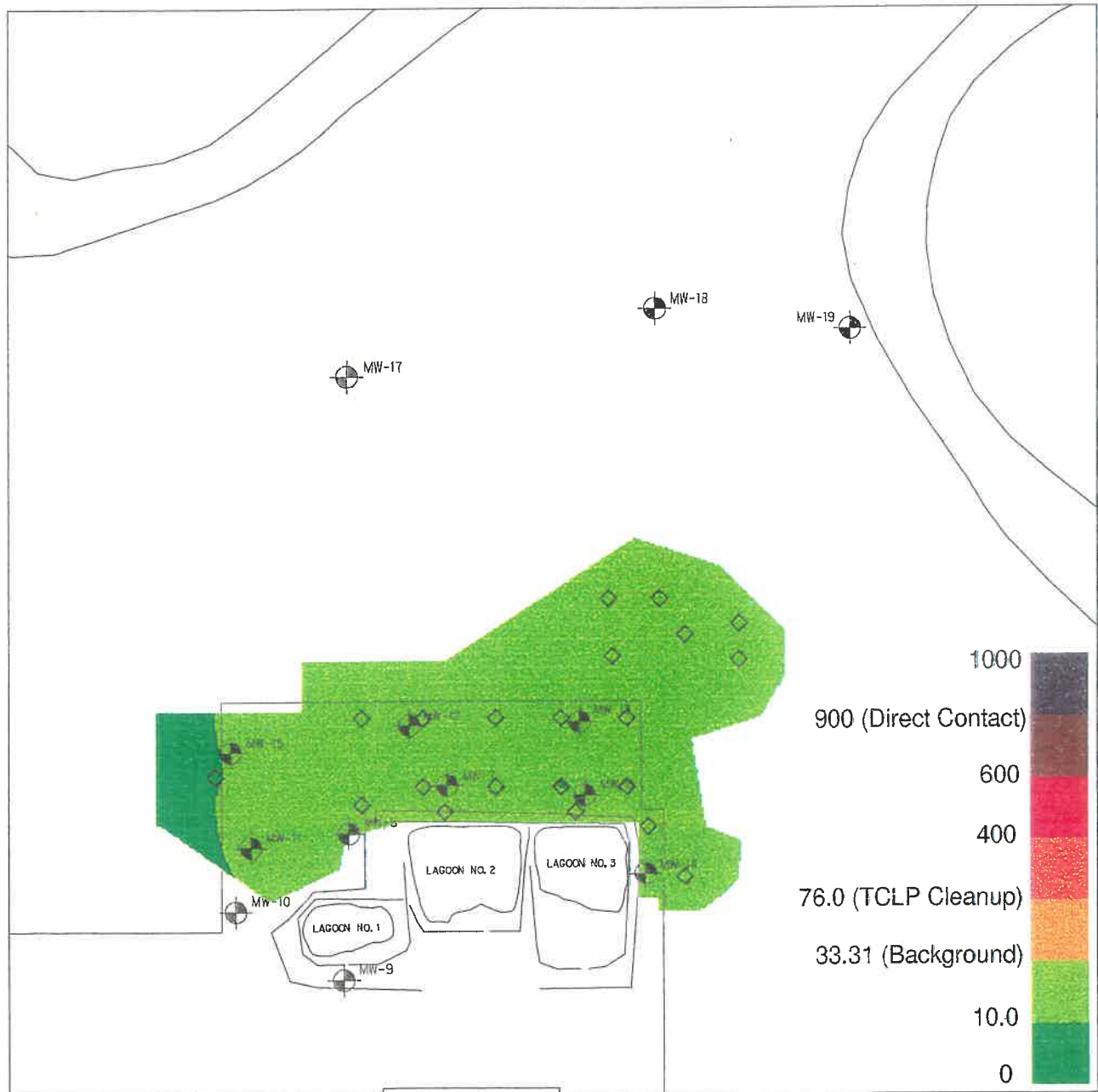

◇ 1994 Soil Sample



Soil Lead Concentrations (mg/kg) 4.5 - 5.5 Feet

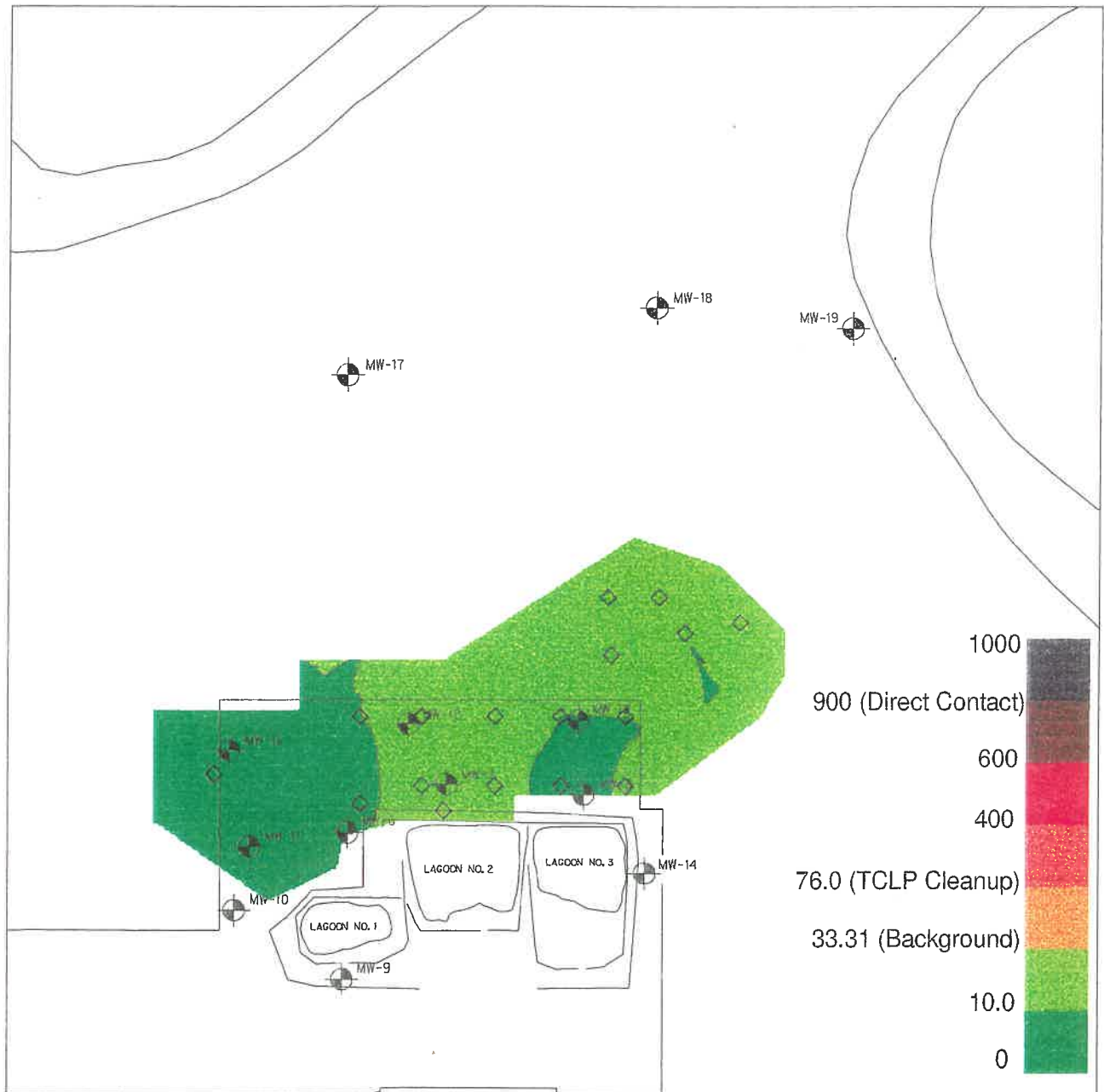

◇ 1994 Soil Sample



Soil Nickel Concentrations (mg/kg) 0.5 - 1.5 Feet

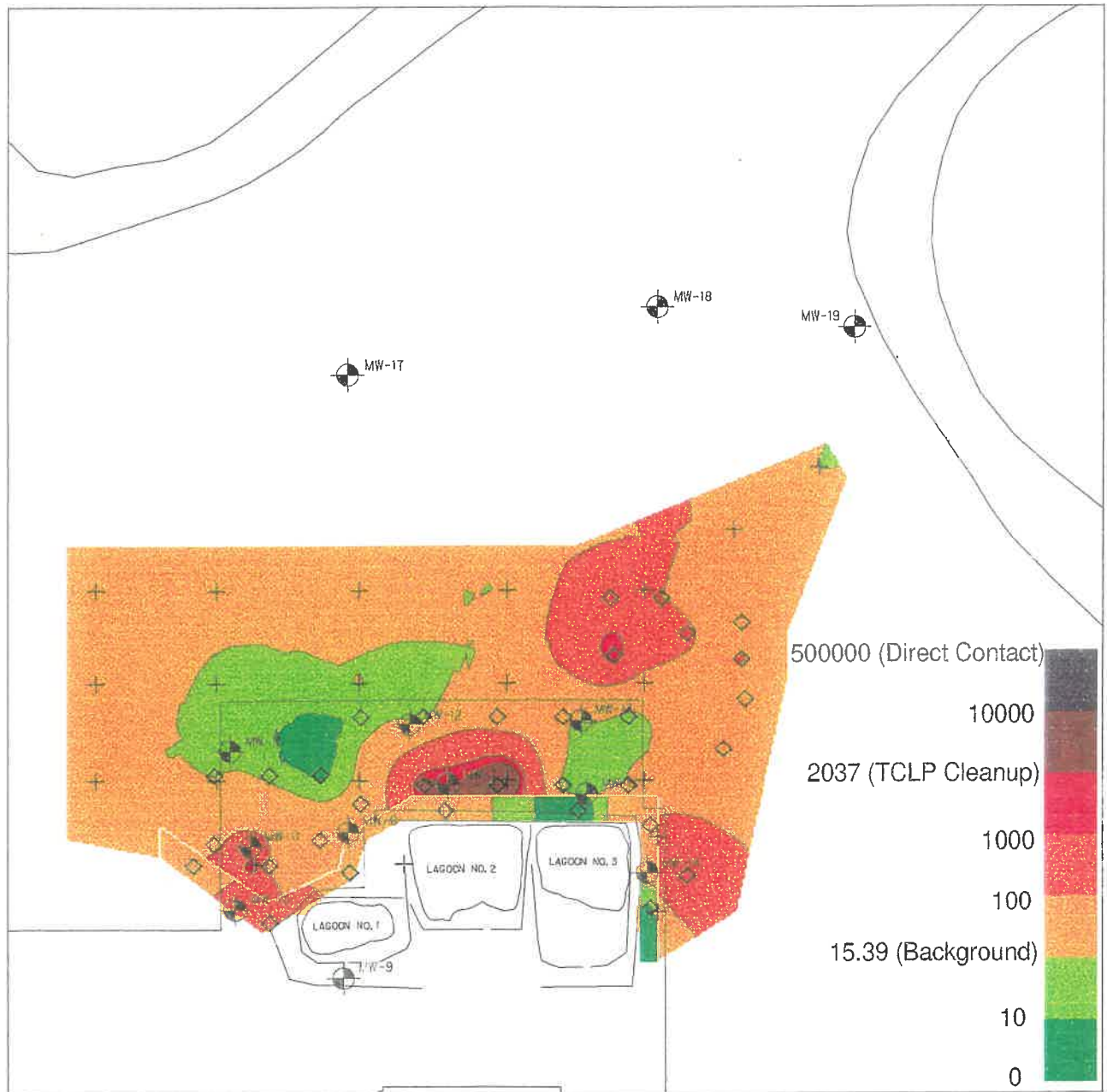

+ 1991 Soil Sample
◇ 1994 Soil Sample



Soil Nickel Concentrations (mg/kg) 2.5 - 3.5 Feet

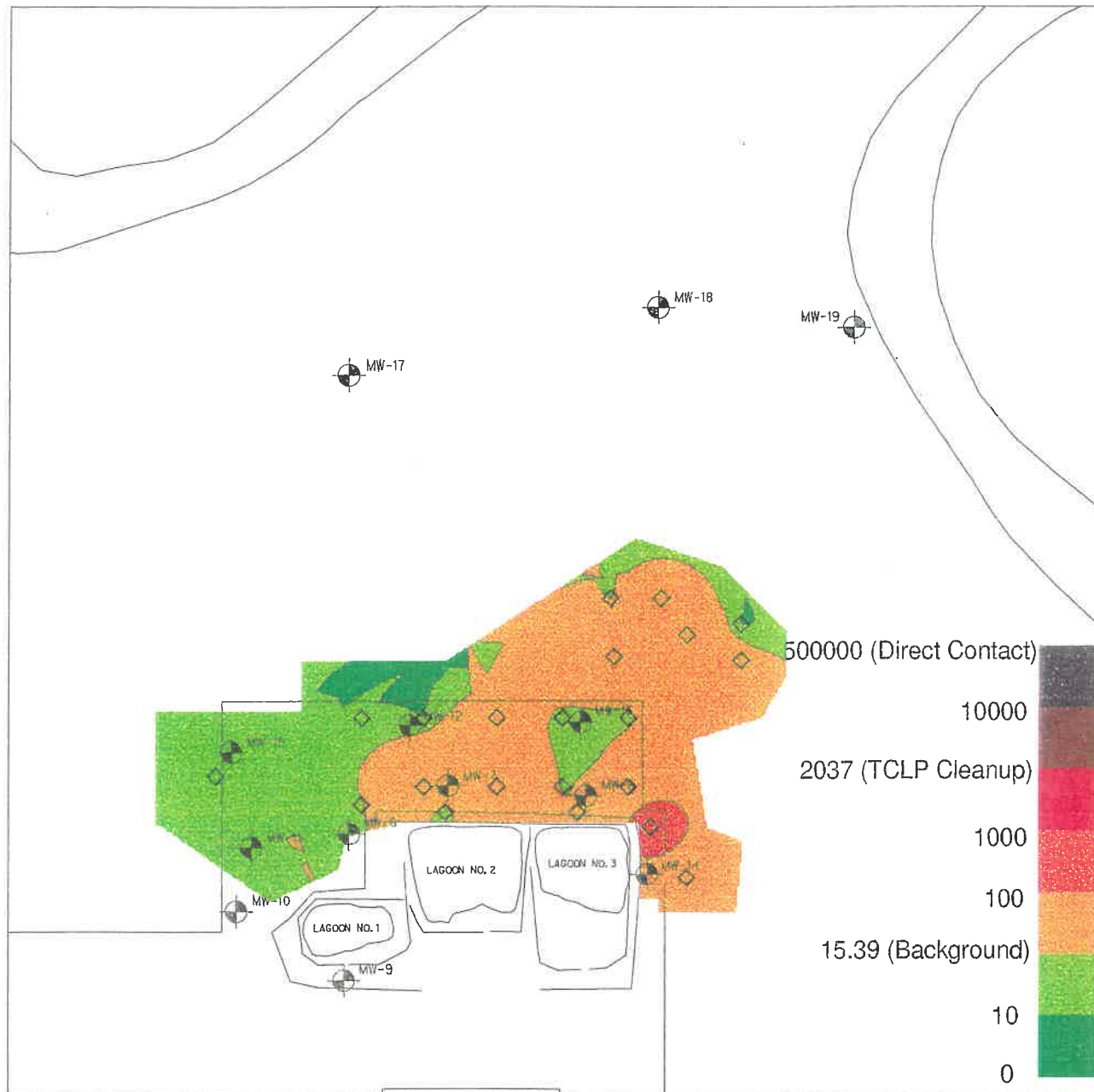

◇ 1994 Soil Sample

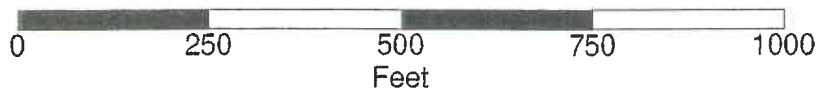

Soil Nickel Concentrations (mg/kg) 4.5 - 5.5 Feet

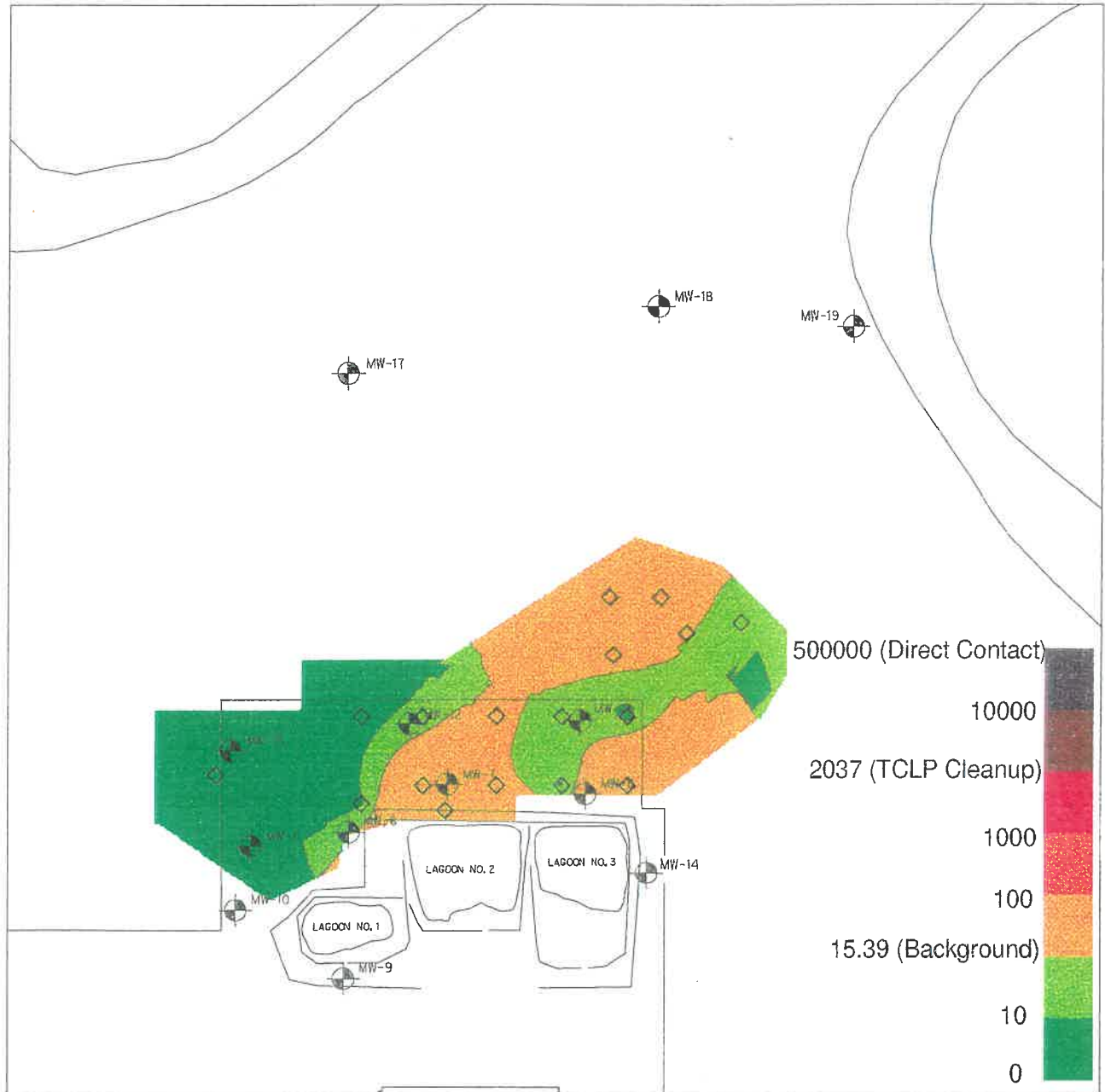

◇ 1994 Soil Sample



Soil Zinc Concentrations (mg/kg) 0.5 - 1.5 Feet

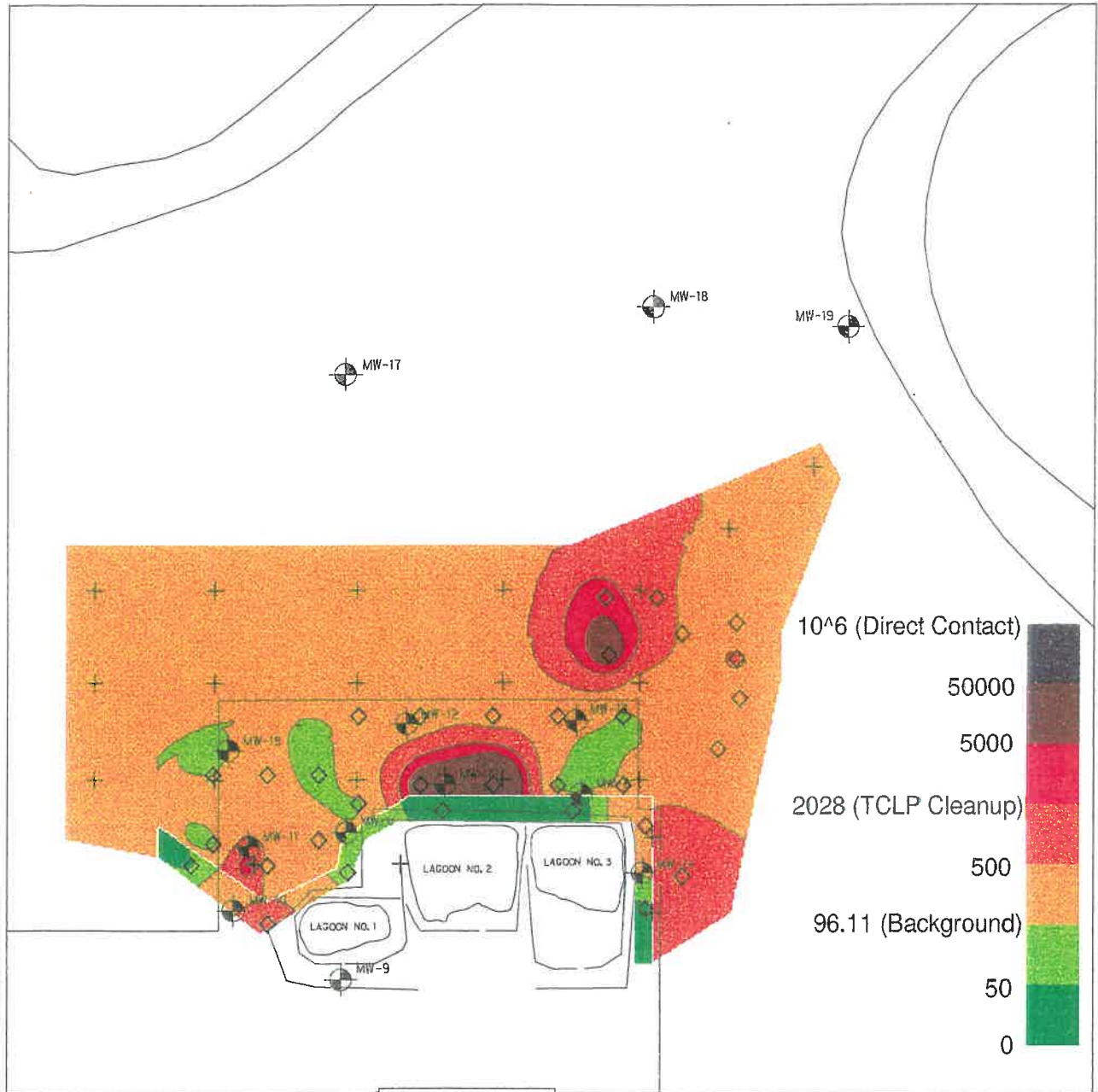

Soil Zinc Concentrations (mg/kg) 2.5 - 3.5 Feet

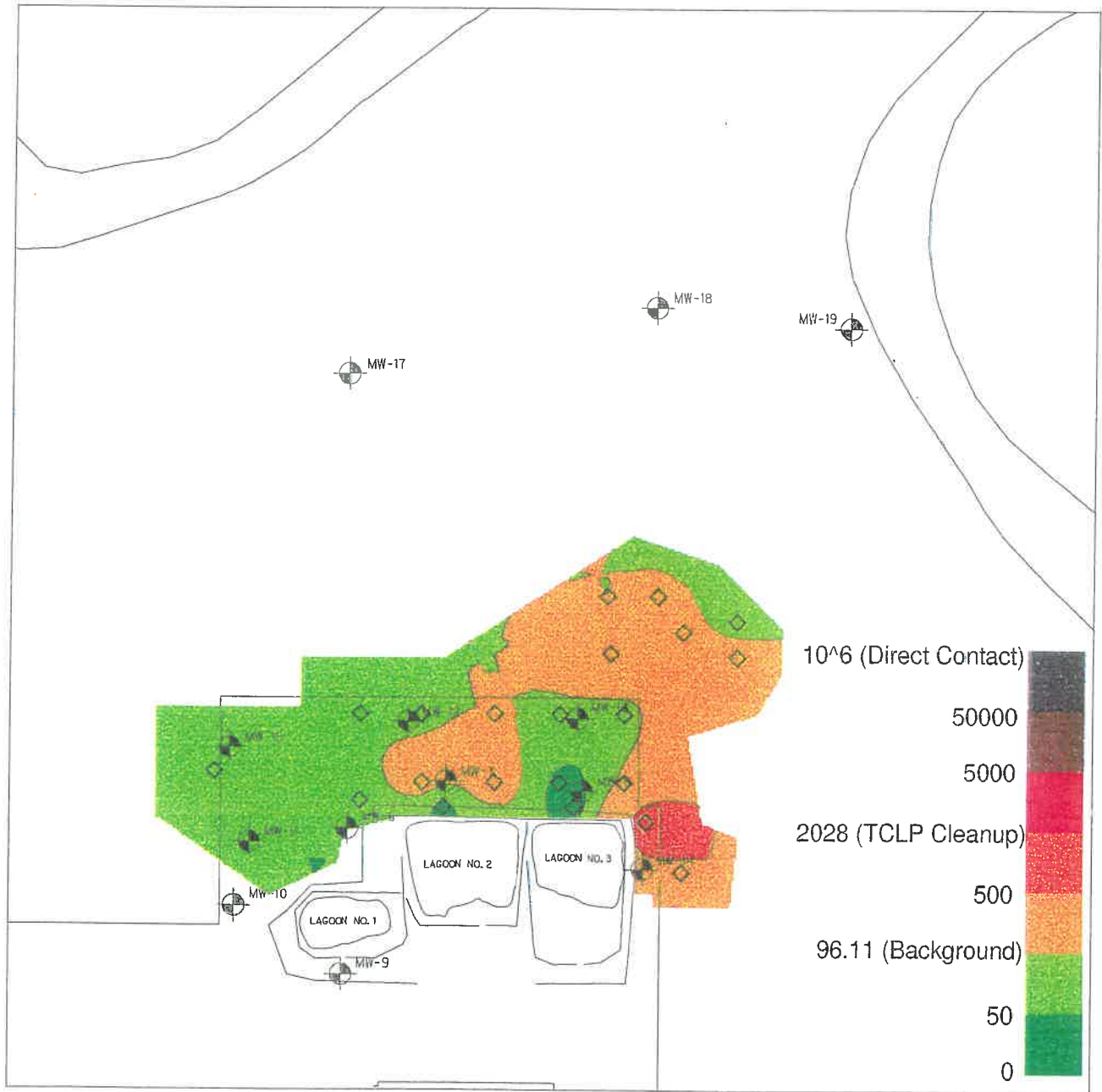

◇ 1994 Soil Sample



Soil Zinc Concentrations (mg/kg) 4.5 - 5.5 Feet

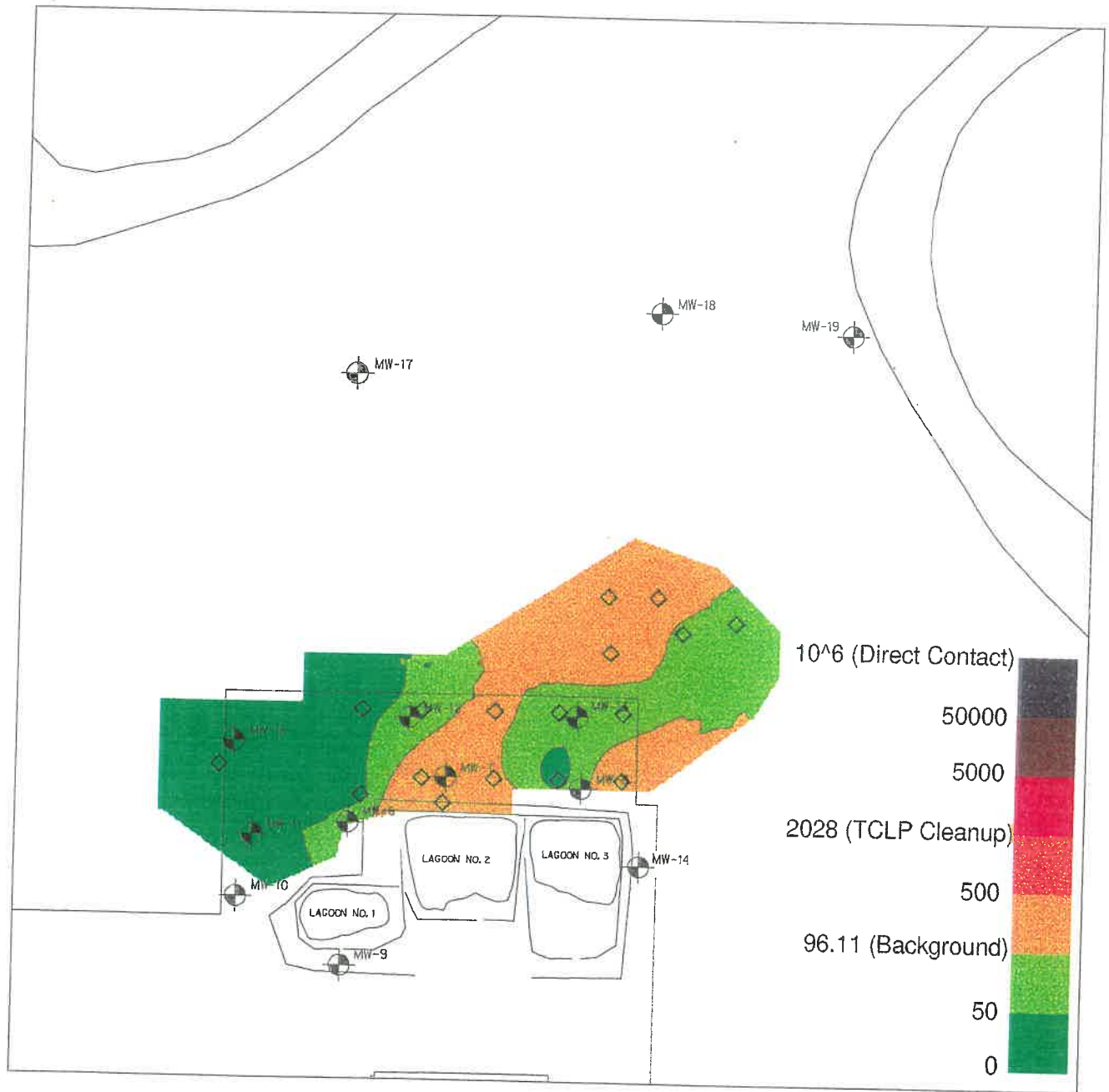

◇ 1994 Soil Sample



Soil cis-1,2-DCE Concentrations (ug/kg) 4.5 - 5.5 Feet



Soil cis-1,2-DCE Concentrations (ug/kg) 0.5 - 1.5 Feet

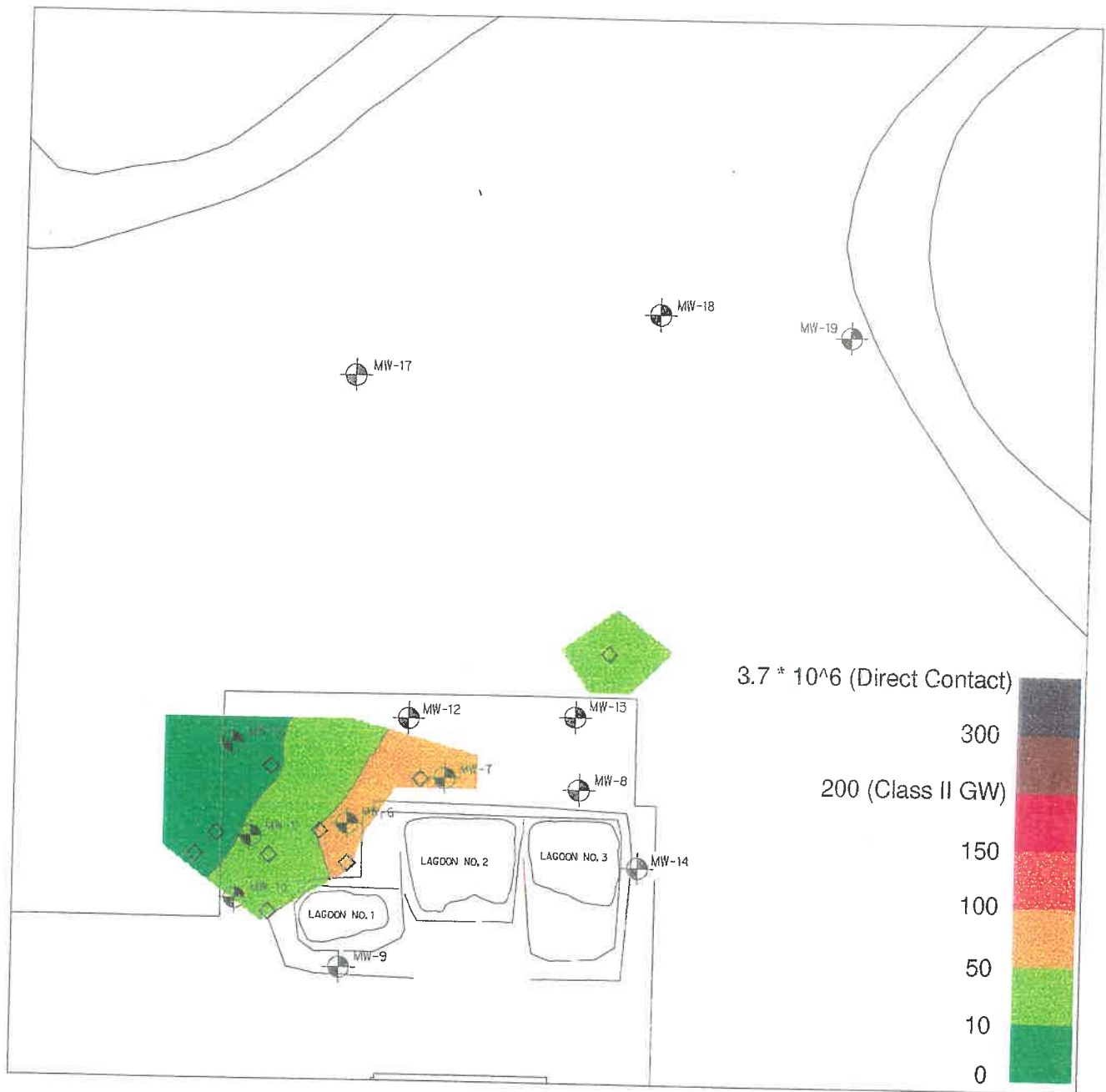

◇ 1994 Soil Sample



Soil Vinyl Chloride Concentrations (ug/kg) 4.5 - 5.5 Feet

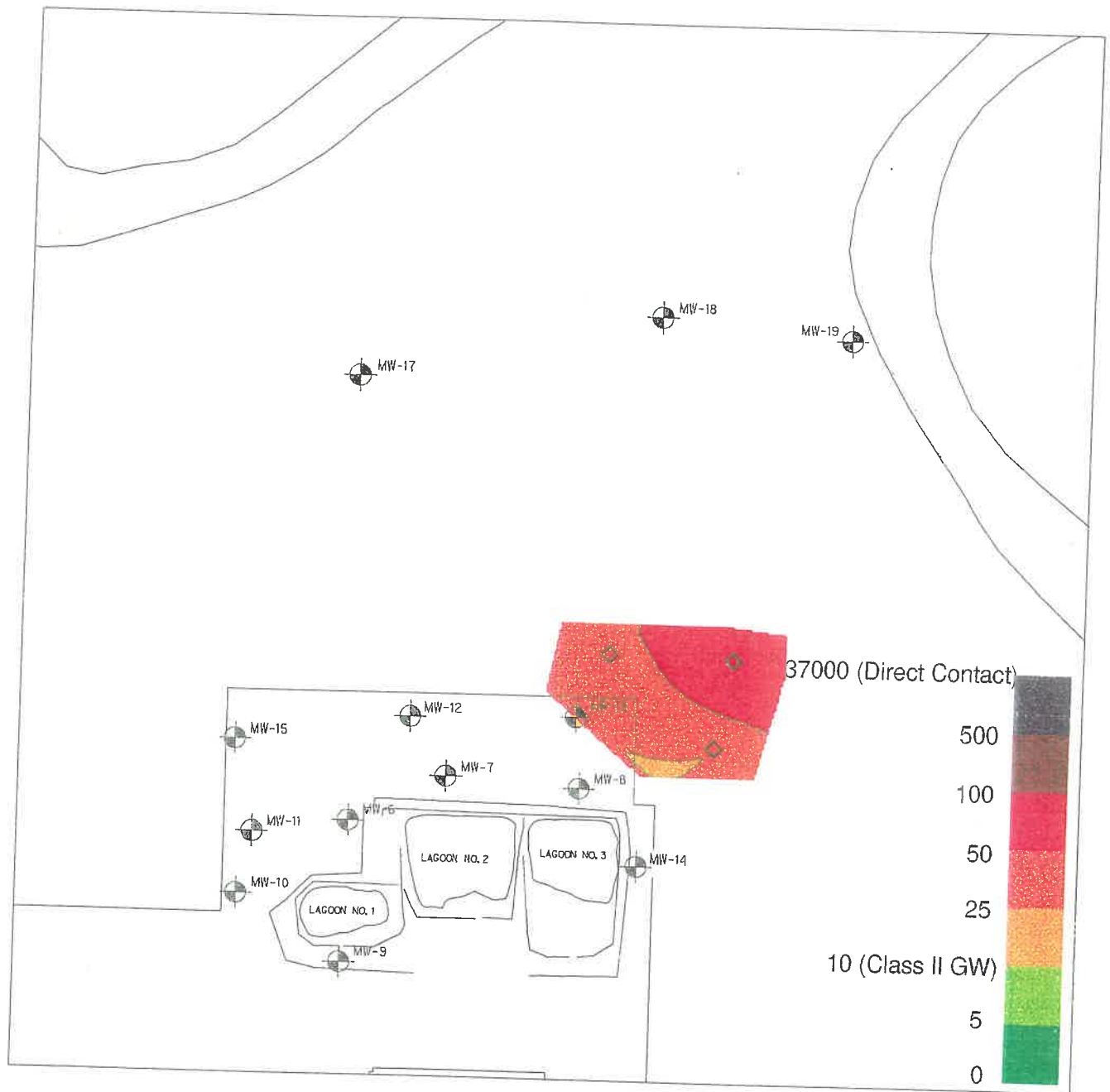

◇ 1994 Soil Sample



Soil Vinyl Chloride Concentrations (ug/kg) 0.5 - 1.5 Feet

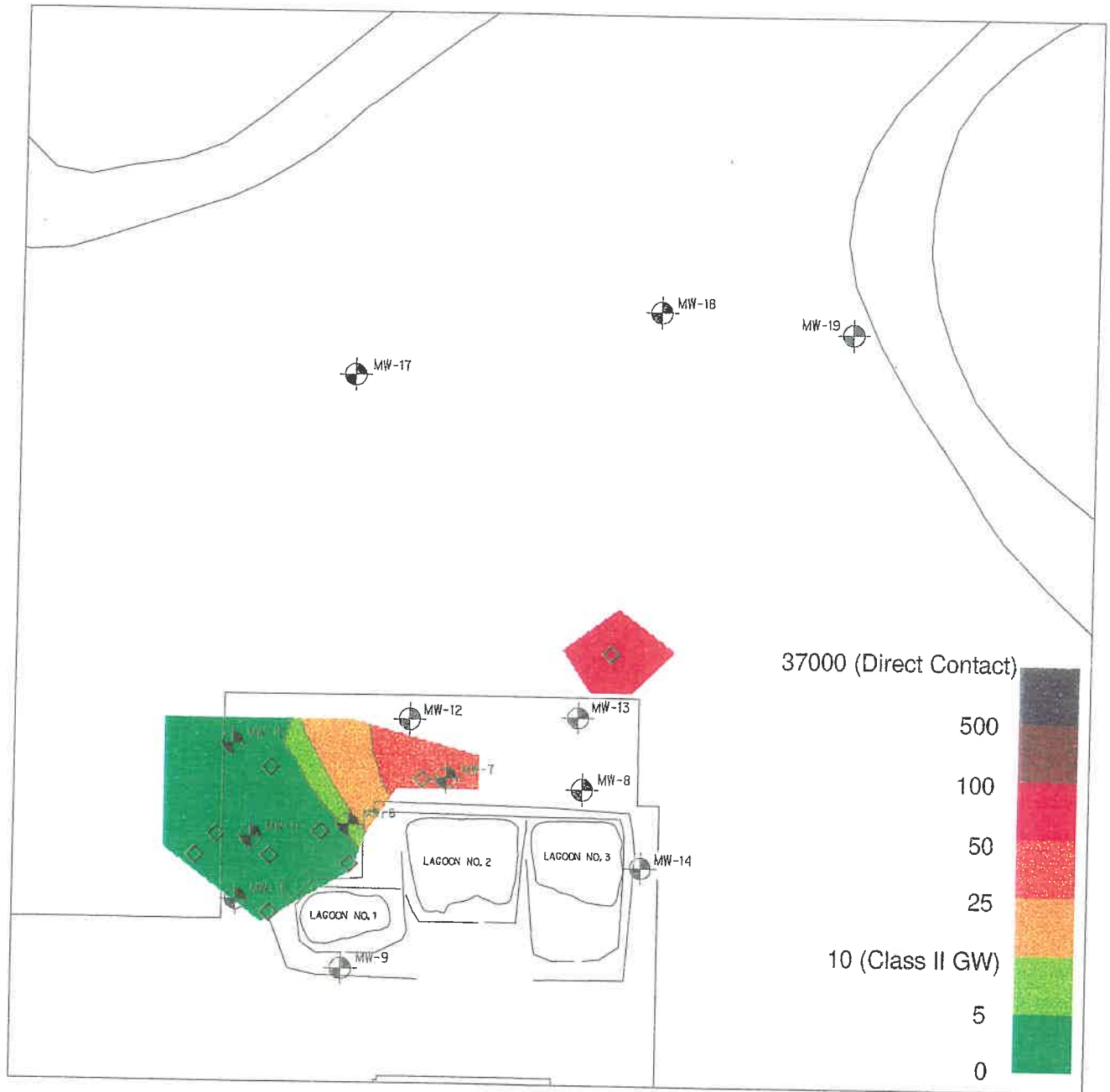

◇ 1994 Soil Sample



Modern Plating Corporation

EP TOX Cadmium - ug/L 0 - 1'

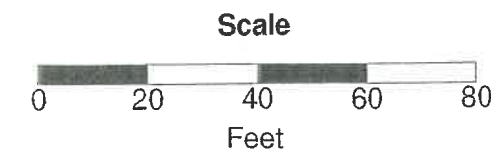
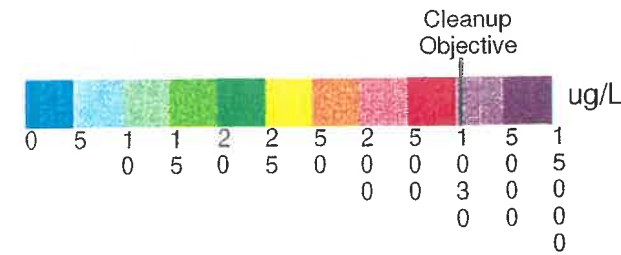
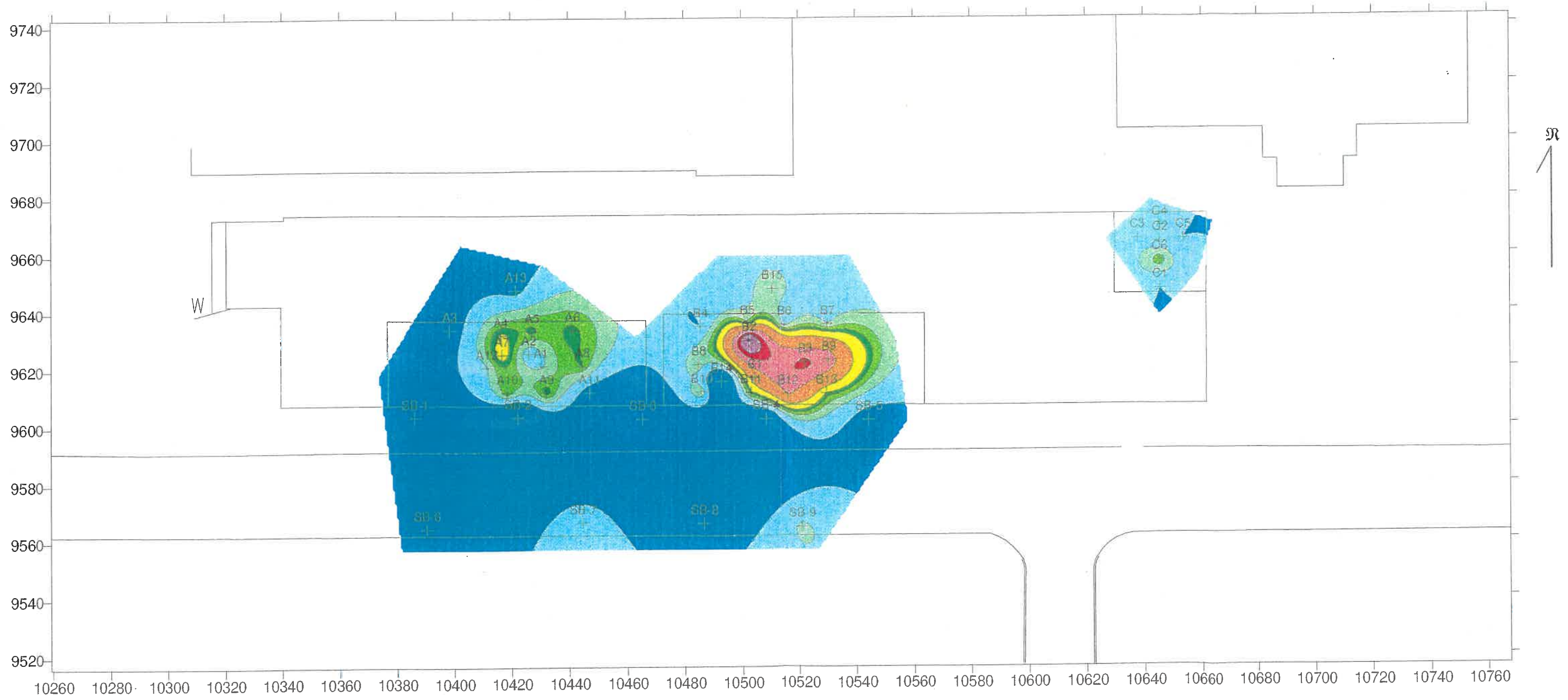

Modern Plating Facility	
Figure 2-A EP TOX Cadmium - ug/L 0-1'	
Scale: 1" = 35'	Date: April, 1995
Prepared By: Foth & Van Dyke	By : SGL

Modern Plating Corporation

EP TOX Cadmium - ug/L 1' - 2.5'

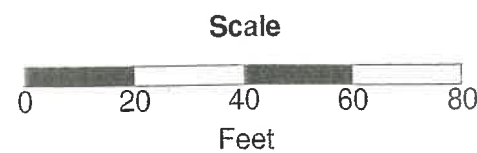
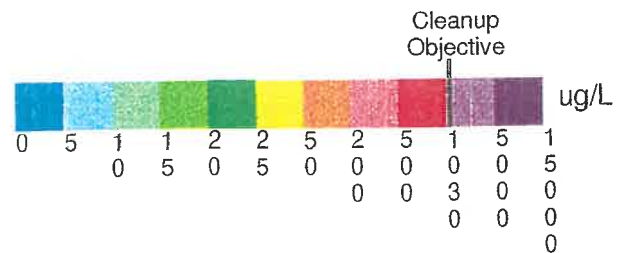
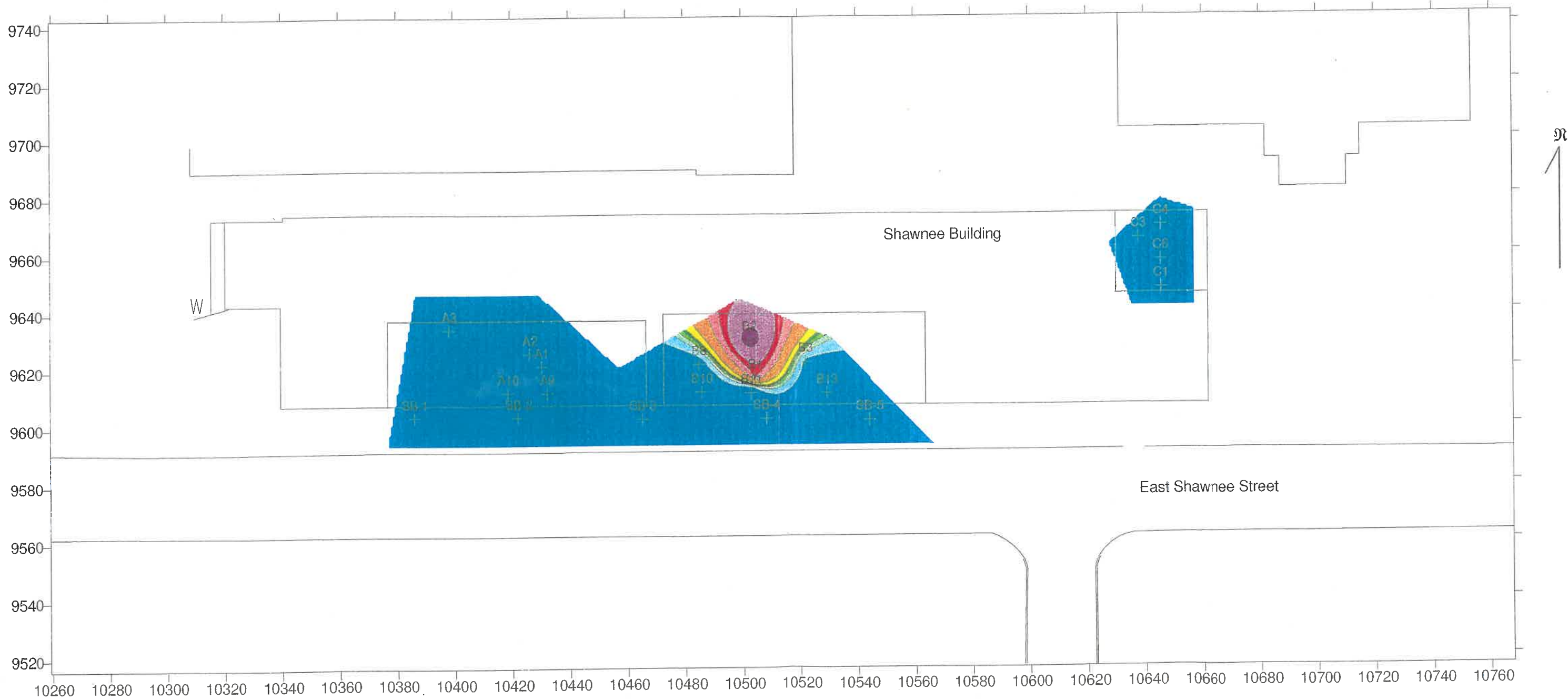

Modern Plating Facility	
Figure 2-B EP TOX Cadmium - ug/L 1'-2.5'	
Scale: 1" = 35'	Date: April, 1995
Prepared By: Foth & Van Dyke	By: SGL

Modern Plating Corporation

EP TOX Cadmium - ug/L 3' - 6'

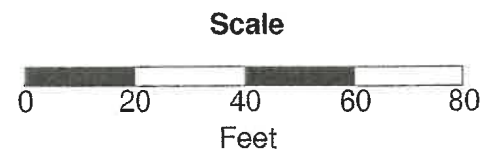
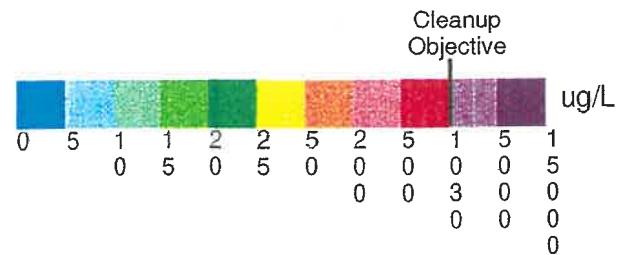
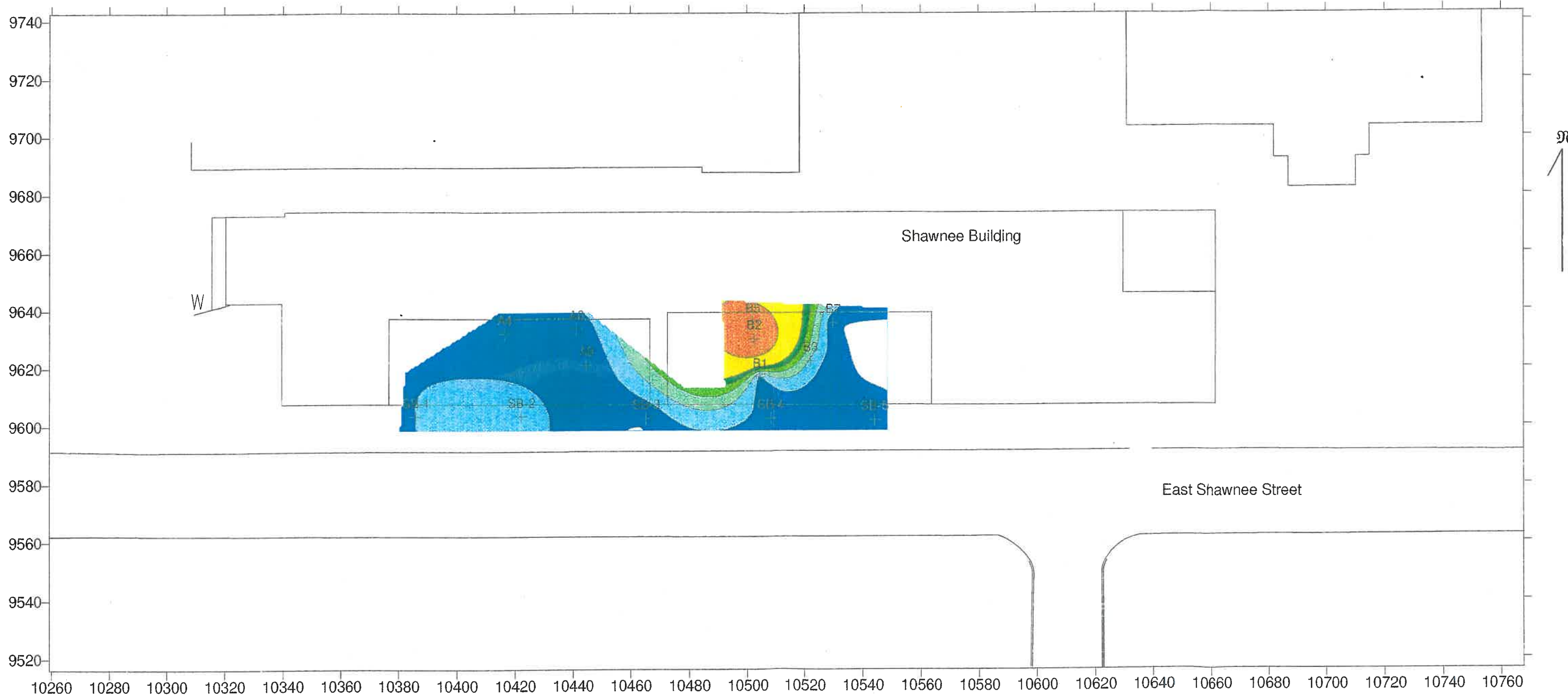

Modern Plating Facility	
Figure 2-C EP TOX Cadmium - ug/L 3'-6'	
Scale: 1" = 35'	Date: April, 1995
Prepared By: Foth & Van Dyke	By : SGL

Modern Plating Corporation

Cyanide - mg/kg 0' - 1'

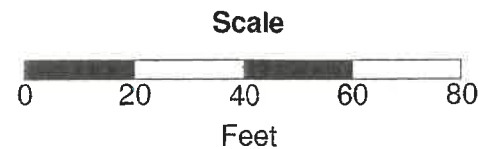
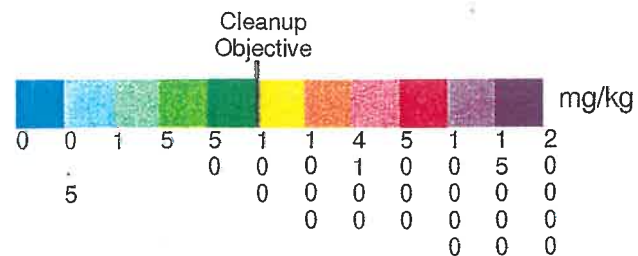
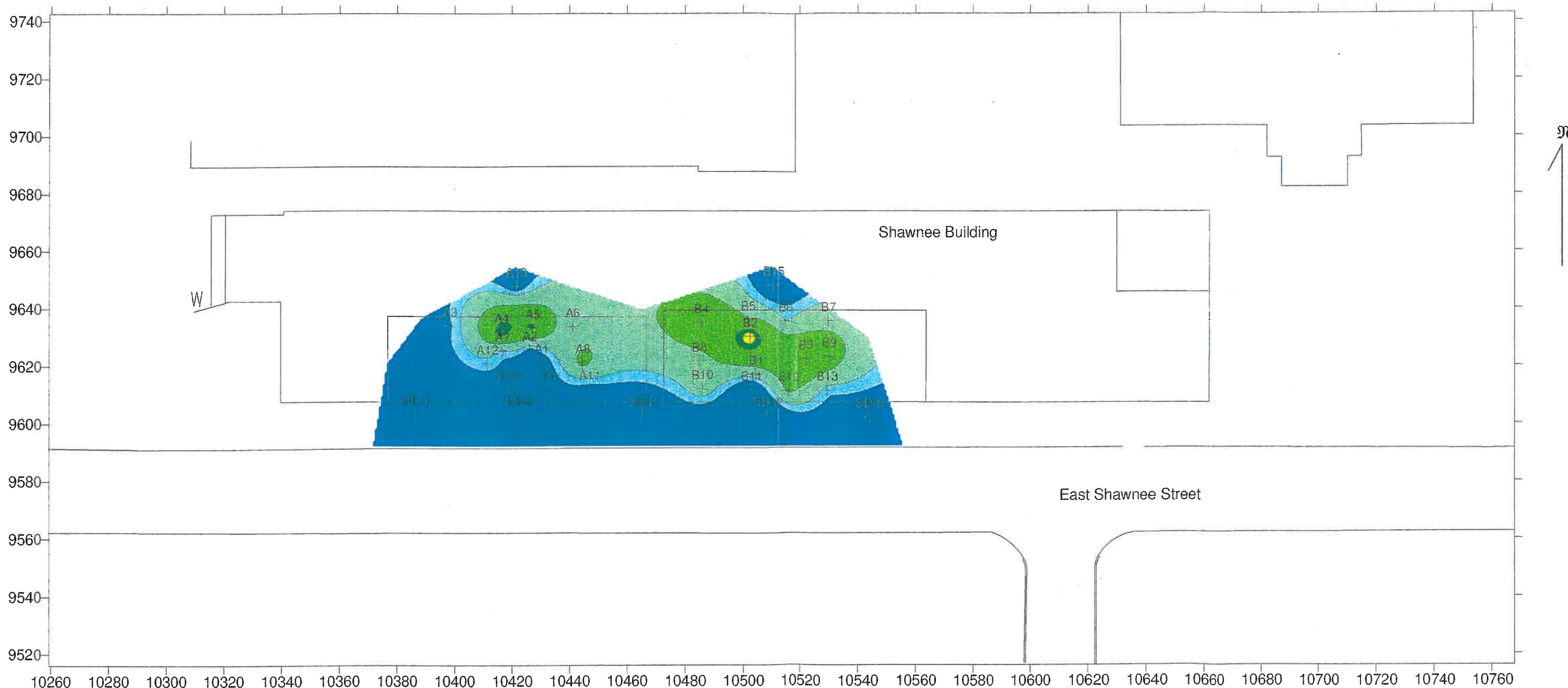

Modern Plating Facility	
Figure 2-D Cyanide - mg/kg 0'-1'	
Scale: 1" = 35'	Date: April, 1995
Prepared By: Foth & Van Dyke	By : SGL

Modern Plating Corporation

Cyanide - mg/kg 3' - 6'

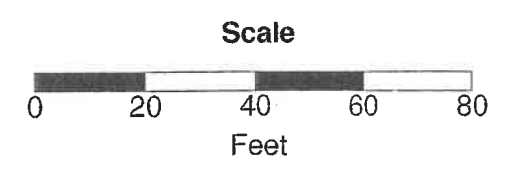
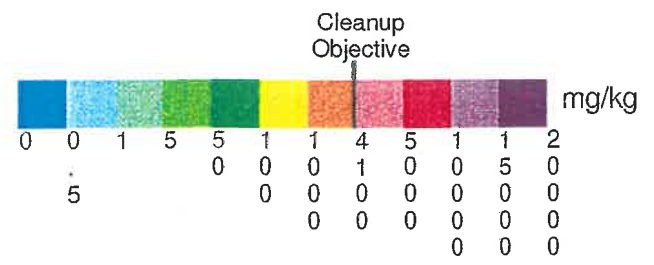
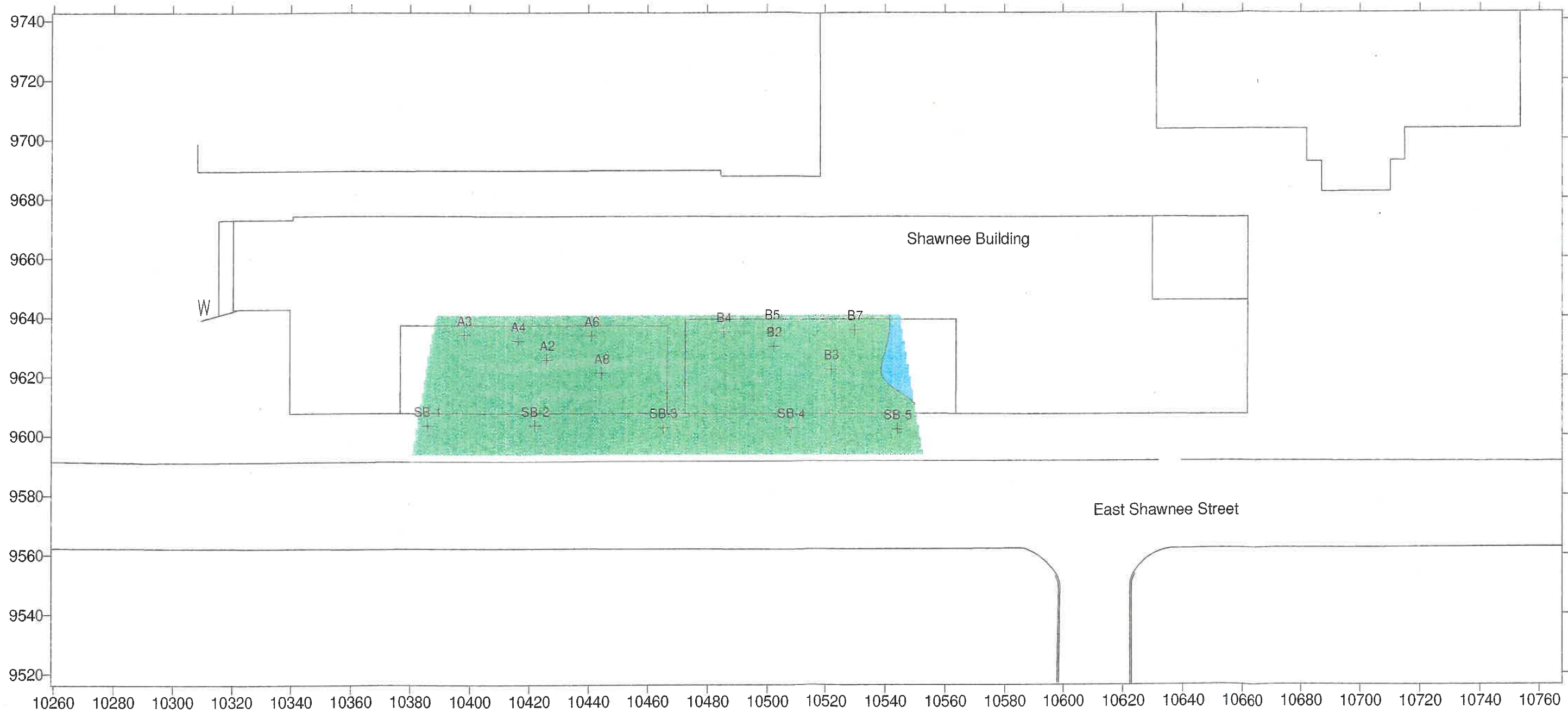

Modern Plating Facility	
Figure 2-E Cyanide - mg/kg 3'-6'	
Scale: 1" = 35'	Date: April, 1995
Prepared By: Foth & Van Dyke	By : SGL

Modern Plating Corporation

Trichloroethene - mg/kg 0' - 1'

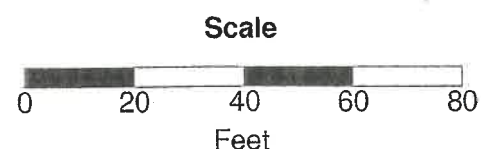
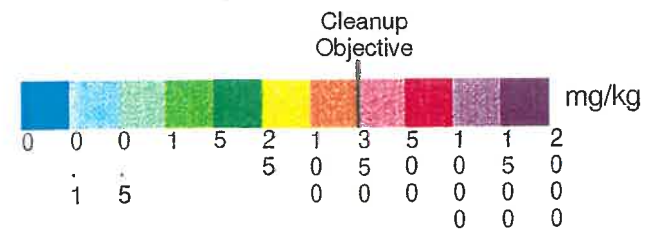
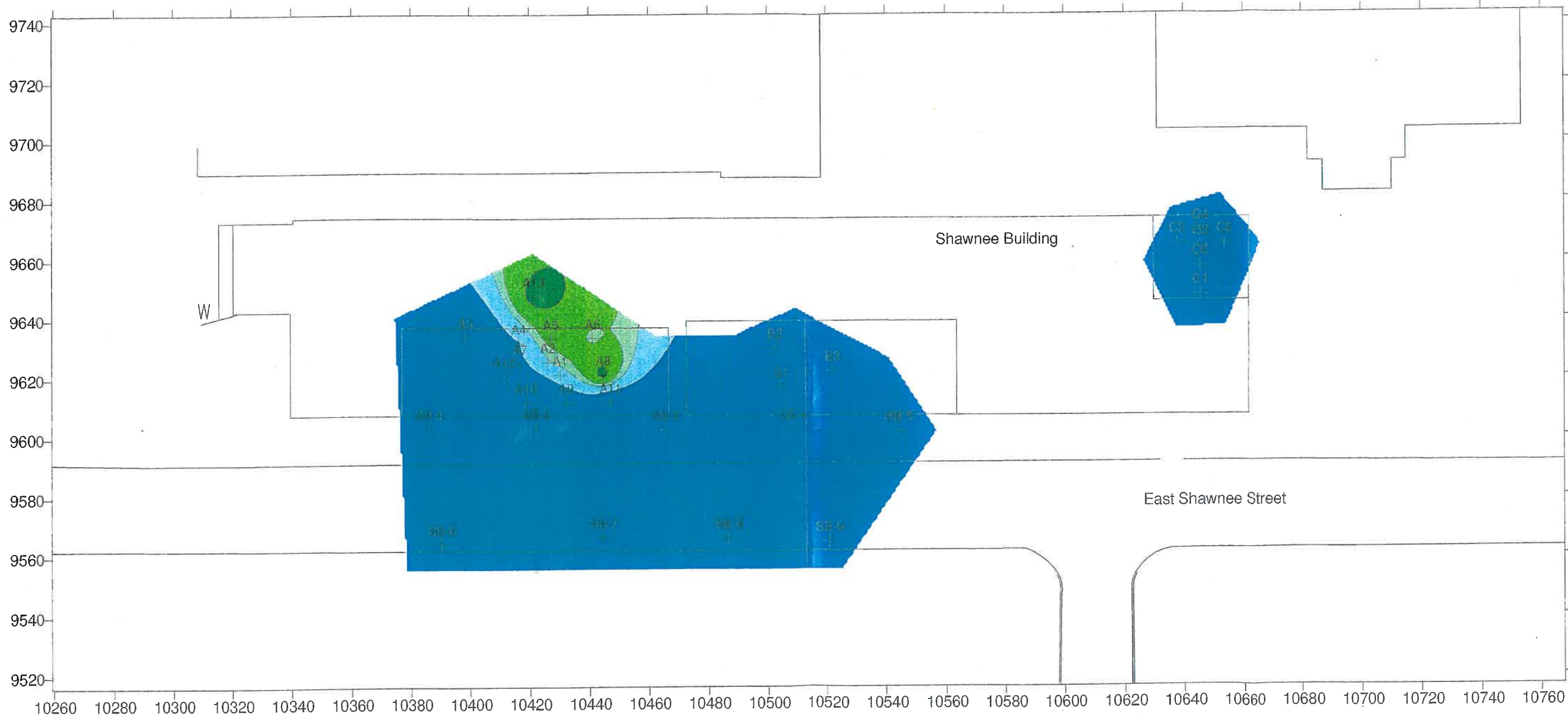

Modern Plating Facility	
Figure 2-F Trichloroethene - mg/kg 0'-1'	
Scale: 1" = 35'	Date: April, 1995
Prepared By: Foth & Van Dyke	By : SGL

Modern Plating Corporation

Trichloroethene - mg/kg 1' - 2.5'

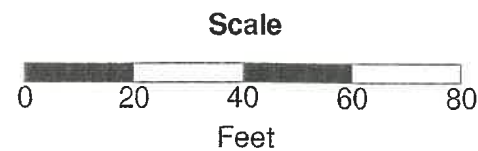
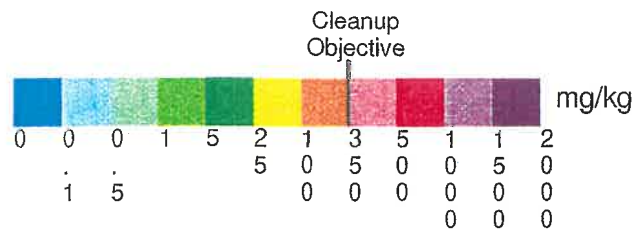
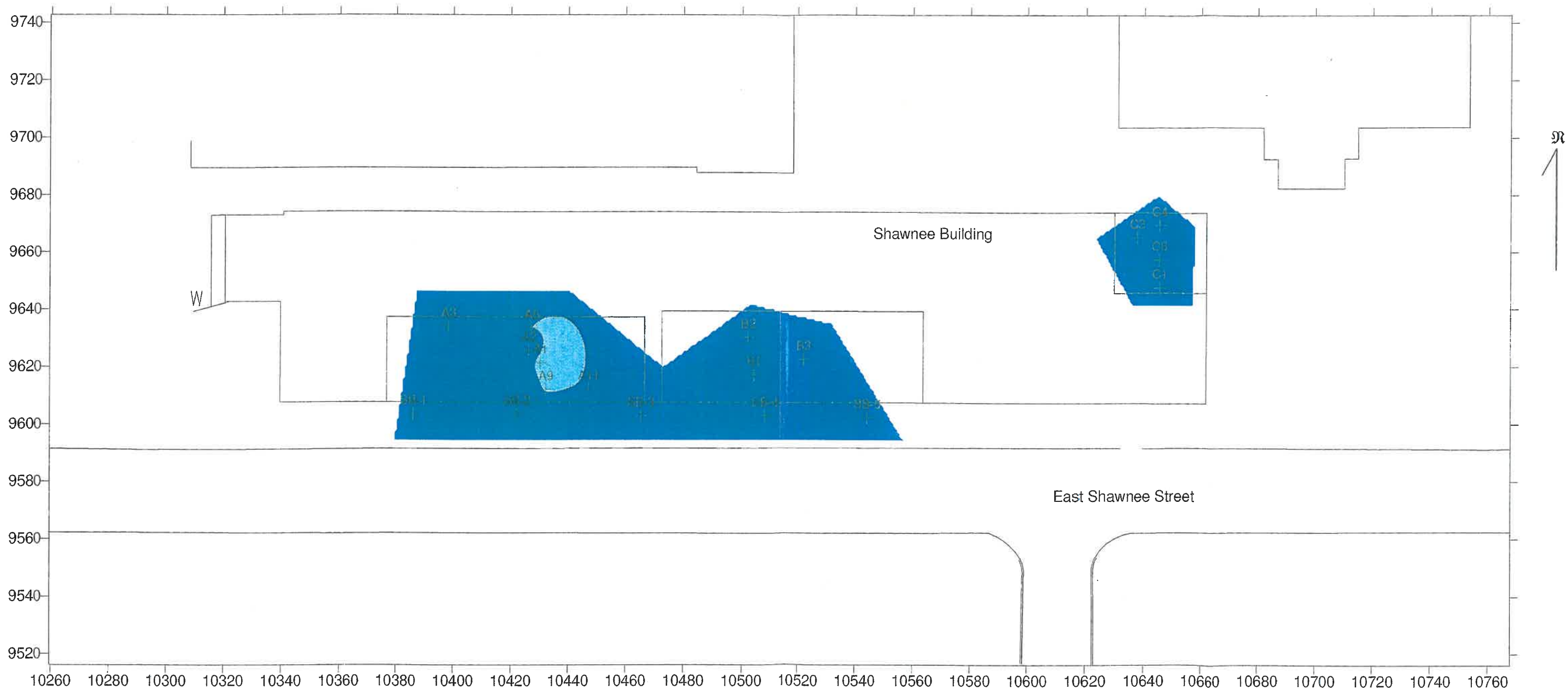

Modern Plating Facility	
Figure 2-G Trichloroethene - mg/kg 1'-2.5'	
Scale: 1" = 35'	Date: April, 1995
Prepared By: Foth & Van Dyke	By : SGL

Modern Plating Corporation

Trichloroethene - mg/kg 3' - 6'

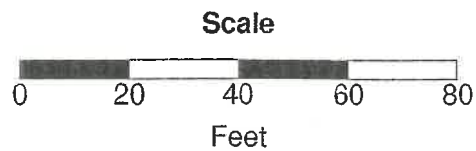
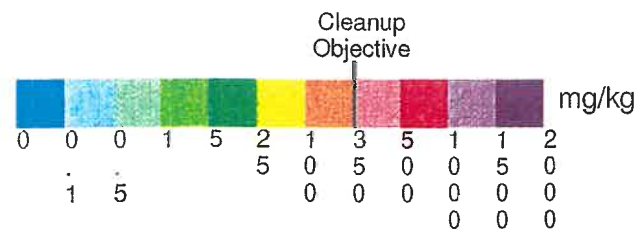
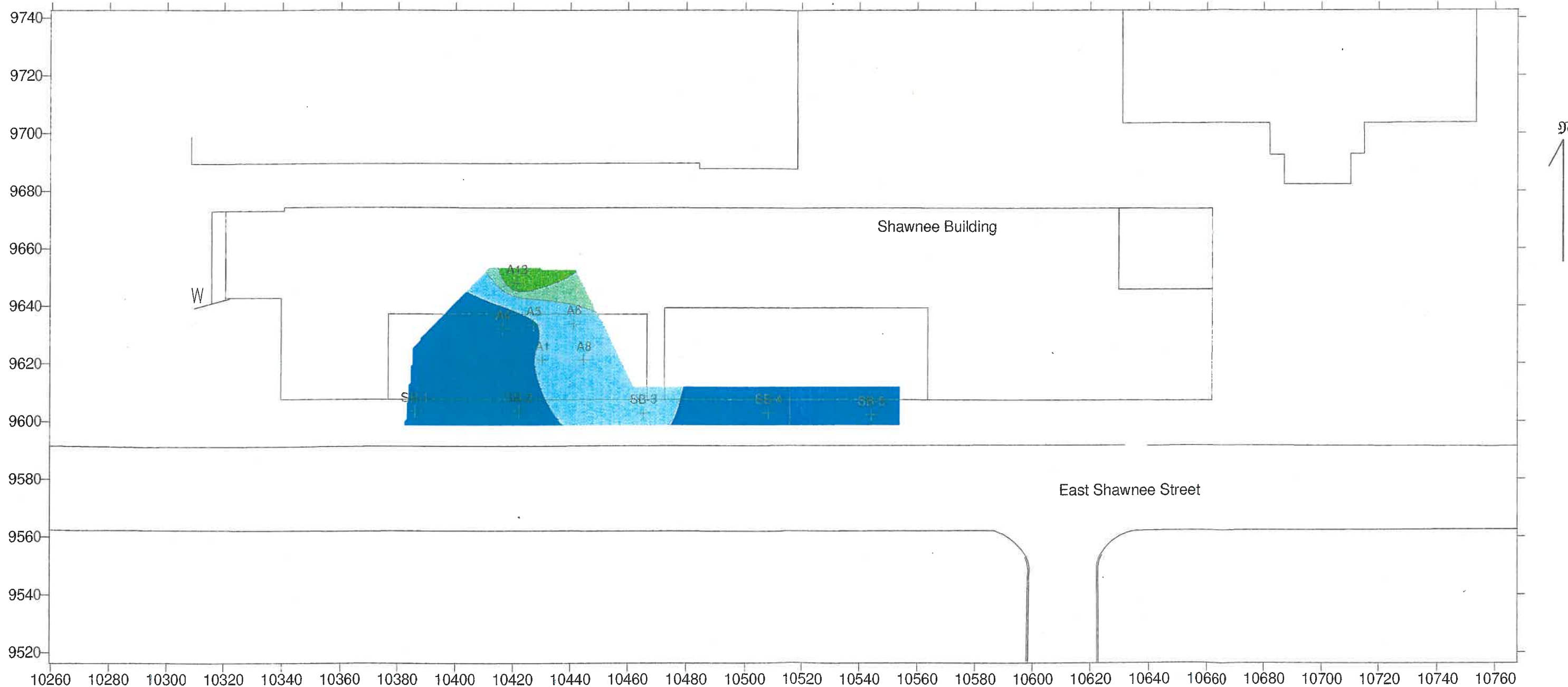

Modern Plating Facility	
Figure 2-H Trichloroethene - mg/kg 3'-6'	
Scale: 1" = 35'	Date: April, 1995
Prepared By: Foth & Van Dyke	By: SGL

Appendix L

Procedures for Sampling Wetland and Other Soils and Sludges from the Revised Construction Quality Assurance Plan and SOPs for Solids/Semi-Solids Sampling and Chain-of-Custody Documentation

The CQAM(s) will also be responsible for all in-place testing in accordance with Table 5-2.

5.2.4 Test Results

MPC to receive all test results as soon as available.

5.3 Contaminated Wetland Soil Excavation and Stockpiling

5.3.1 Wetland Soil Excavation

- ◆ Stake boundaries of contaminated soil areas.
- ◆ As contaminated soil is excavated, determine when the target cadmium concentration (200 ppm or lower) has been achieved. Obtain the number of soil samples listed in Table 5-2a at the locations listed. Ship the samples out to the laboratory the same day. In addition, analyze for the presence of volatile organic compounds with a photoionization detector.
 - ▶ record date, time, location, depth of each sample
 - ▶ extend excavation vertically to a minimum depth of 2 ft, then extend excavation vertically or laterally until a concentration of cadmium of <200 mg/kg or less is reached. Note that a decision to extend the excavation will be made after the results of the analysis have been received from the laboratory.

5.3.2 Lagoon 1A (and Lagoon O, if required) Preparation and Filling

- ◆ Confirm that clay cover is removed from the lagoon.
- ◆ Check soil compaction at the rate of one density test for each 1-ft lift of soil placed for each 100 ft of berm constructed.
- ◆ Observe and record, by twice daily photographs, the placement of soil in the prepared lagoon area.
- ◆ Document placement of the temporary cover, including the anchoring and sand bagging of the tarp.
- ◆ Survey final grades of contaminated soil pile(s).

5.4 Lagoon Sludge and Contaminated Soil Excavation

- ◆ The RCRA Part B permit requires that the lagoons be over-excavated a minimum of 1 ft below the sludge.
- ◆ After over-excavation is completed, observe base of lagoon for staining, check for VOCs in the soil with the TIP (or PID).

- ◆ As per condition Section IV, C.1.c. - 2 ft of contaminated soil shall be excavated from the floor and side walls of the cyanide vault area.
- ◆ Sample the soils following the same protocols are described in 5.3.1 above for wetland soil excavation.
- ◆ Call the office if contamination below 1 ft is apparent.

Table 5-2a

MPC Remediation - Confirmation Soil Sampling*

Unit	Number of Samples/Location	Parameters**
✓ Cyanide Vault	4/2 bottom - 2 sideslopes	(4) CN and Metals
✓ Shawnee Building	4/bottom	(4) Cd only
Wetland 1 and 1A	6/4 exterior - 2 interior	(6) Cd only
Wetland 2	7/5 exterior - 2 interior	(7) Cd only
Wetland 3	8/5 exterior - 3 interior	(8) Cd only
✓ Lagoon No. 1A	8/5 bottom - 3 sideslopes	(8) CN and Metals
✓ Lagoon No. 0	6/3 bottom - 3 sideslopes	(6) CN and Metals
✓ Lagoon No. 1	8/5 bottom - 3 sideslopes	(8) CN and Metals
✓ Lagoon No. 2	10/6 bottom - 4 sideslopes	(10) CN and Metals
✓ Lagoon No. 3	10/6 bottom - 4 sideslopes	(10) CN and Metals
Outfall Pipeline	?	?

Cd = Cadmium only - 25
 CN = Cyanide
 Metals = Arsenic, Cadmium, Lead, Nickel, Zinc

* The number of samples may be increased or decreased depending on conditions.

** As per condition RCRA part B, Section I.C.3 "Waste which contain free liquids as determined by the paint filter liquids test (Method 9095)...shall not be placed in the CAMU Landfill." Therefore, complete paint filter tests on ALL wastes suspected of having free liquids (primarily the sludges). Tests should be completed at the rate of ~1 per 500 to 1,000 cy of sludge, prior to placing the sludge in the CAMU Landfill. Refer to Attachment 5 for Paint Filter Test Methods.

Organizational Unit: GEM	Foth & Van Dyke <i>Engineers Architects Planners Scientists Economists</i>	Reference No.: 340.30
Prepared by: RTJ		Sheet R002131 1 of 1
Approved by: GWS		Date: 8/14/89
File Ref.: GEMSOP 340.30		Supersedes: NEW

**EQUIPMENT SELECTION
SOLIDS/SEMI-SOLIDS**

PURPOSE:

To collect environmental samples that are representative of the medium being sampled.

DEFINITION:

"Solids/Semi-solids" includes but is not limited to, soils, sludge, sediments, and bulk materials.

POLICY:

None.

CONSIDERATION:

The sampling of solid or semi-solid materials is complicated by the structural properties of the material. The presence of entrapped gasses and fluids is often an integral part of the substance, and may be of some consequence with respect to the reason the sample was collected. It is necessary to collect a sample which does not alter this balance. Further, the physical strength and density of the material demand sampling devices of significant rigidity and strength. As a result, a great deal of disturbance will occur at the sample-sampler interface. These effects must be minimized through careful sampling and by collecting samples with a high volume-to-surface area ratio.

A solid does not necessarily have uniform characteristics with respect to distance or depth. Those portions which form boundaries with the container, define the edges of a pile, or contact the atmosphere are likely not indicative of the material as a whole. Therefore, in order to prevent aeration or moisture content changes, samples should be tightly capped and protected from direct light.

Most commercially-available solid sampling devices are steel, brass, or plastic. In general, use of stainless steel or Teflon-coated equipment is the most practical and affects the sample quality least. The use of chrome or nickel-plated steel devices is discouraged because of the potential effect on the results of trace metal analysis.

PROCEDURE:

None.

Organizational Unit: GEM	Foth & Van Dyke <i>Engineers Architects Planners Scientists Economists</i>	Reference No.: 380.10
Prepared by: RTJ		Sheet 1 of 2
Approved by: GWS		Date: 07/18/90
File Ref.: GEMSOP 380.10		Supersedes: 8/14/89

SAMPLE EVENT DOCUMENTATION
CHAIN-OF-CUSTODY

PURPOSE:

To maintain sample integrity through the documentation of sample possession from collection through receipt at the analytical lab.

DEFINITION:

"Chain-of-custody" is described in the body of this SOP.

POLICY:

Foth & Van Dyke Blue Book Section 200.
GEM SOP Manual Reference No. 110.00.

CONSIDERATION:

Samples are physical evidence and must be handled according to certain procedural safeguards in order to assure their integrity and, to a certain degree, the integrity of the results. For purposes of legal proceedings, a demonstration to the court may require a comprehensive chain-of-custody demonstration in which it will be necessary to trace the custody of samples from the point of collection through completion of sample analyses. This means that, in addition to field handling and subsequent transport to the lab, the laboratory itself must be prepared to produce documentation that traces the "in-house" custody of the samples.

The National Enforcement Investigation Center (NEIC) of EPA defines custody of evidence in the following manner:

- it is one's actual possession, or
- it is in one's view, after being in one's physical possession, or
- it was in one's possession and then locked and/or sealed to prevent tampering, or
- it is in a secure area.

Chain-of-custody begins at the laboratory as part of the sample bottle preparation and use of the shipping container. Foth & Van Dyke requires the use of a chain of custody record in

Organizational Unit: GEM	Foth & Van Dyke <i>Engineers Architects Planners Scientists Economists</i>	Reference No.: 380.10
Prepared by: RTJ		Sheet 2 of 2
Approved by: GWS		Date: 07/18/90
File Ref.: GEMSOP 380.10		Supersedes: 8/14/89

conjunction with the collection of environmental samples. An example of an acceptable chain of custody can be found on the next page. It shall be the scope liaison's (or his designee's) responsibility to assure that the required chain of custody procedures are followed. The legal requirements for maintaining custody established by Federal and state agencies as well as courts of law are:

- labelling of sample bottles, packing the sample shipping container and transferring that container under seal to a shipper;
- outgoing shipping papers (as applicable);
- chain-of-custody forms which are completed by the person(s) breaking the shipping container seal, procuring the sample, filtering and preserving the sample (if necessary), packing the sample, resealing the shipping container, and transferring custody to a shipper;
- incoming shipping papers (@ lab) (as applicable);
- breaking the shipping containers reseal, documenting the condition of the samples received as well as the time received;
- storing each labelled sample bottle in a secured area;
- disposition of each sample to an analyst or technician; and
- the use of the sample in each bottle in a testing procedure appropriate to the intended purpose of the sample.

The record must show for each link in this process:

- the person with custody; and
- the time and date each person accepted and relinquished custody.

Only those laboratories and sampling personnel which meet or exceed these chain-of-custody requirements shall be used for project work.

PROCEDURE:

None.

SOP reference(s): 1090.03

Appendix M

Wetland Soils and Shawnee Building Soil - Conformation Location Sketches, Cadmium Analysis and Chain-of-Custody Forms

Wetland No. 1
AREA I
Sample locations
2/23/00

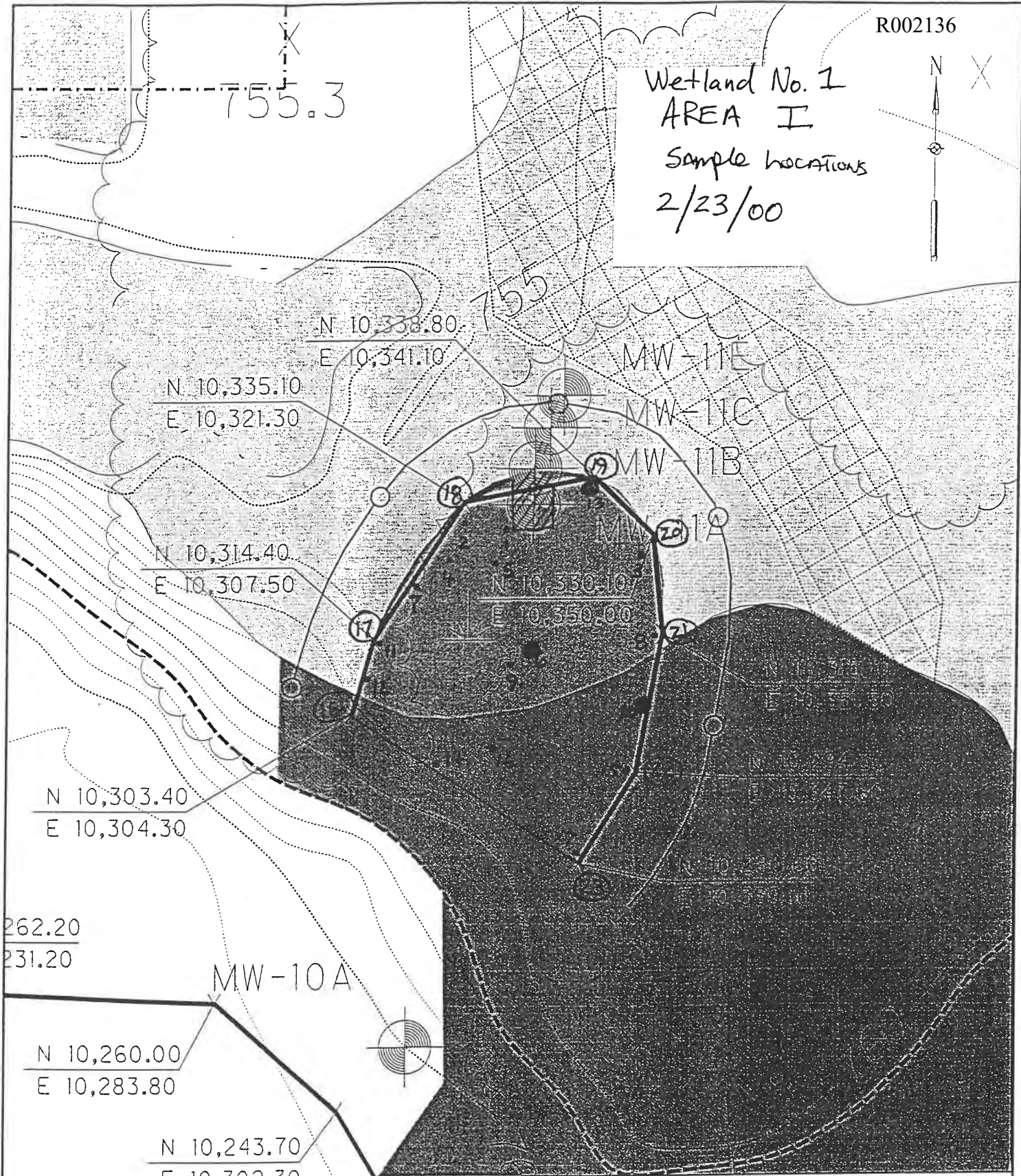

262.20
231.20

N 10,303.40
E 10,304.30

N 10,314.40
E 10,307.50

N 10,335.10
E 10,321.30

N 10,338.80
E 10,341.10

N 10,350.10
E 10,350.00

N 10,260.00
E 10,283.80

N 10,243.70
E 10,302.30

N 10,211.70
E 10,322.10

NOTE: UNEXCAVATED AREA

Survey points

Sample points

MODERN PLATING CORP.

FIGURE A

A
A

Scale:

Date: FEBRUARY, 2000

Prepared By: Foth & Van Dyke

By: 97M015

JOW

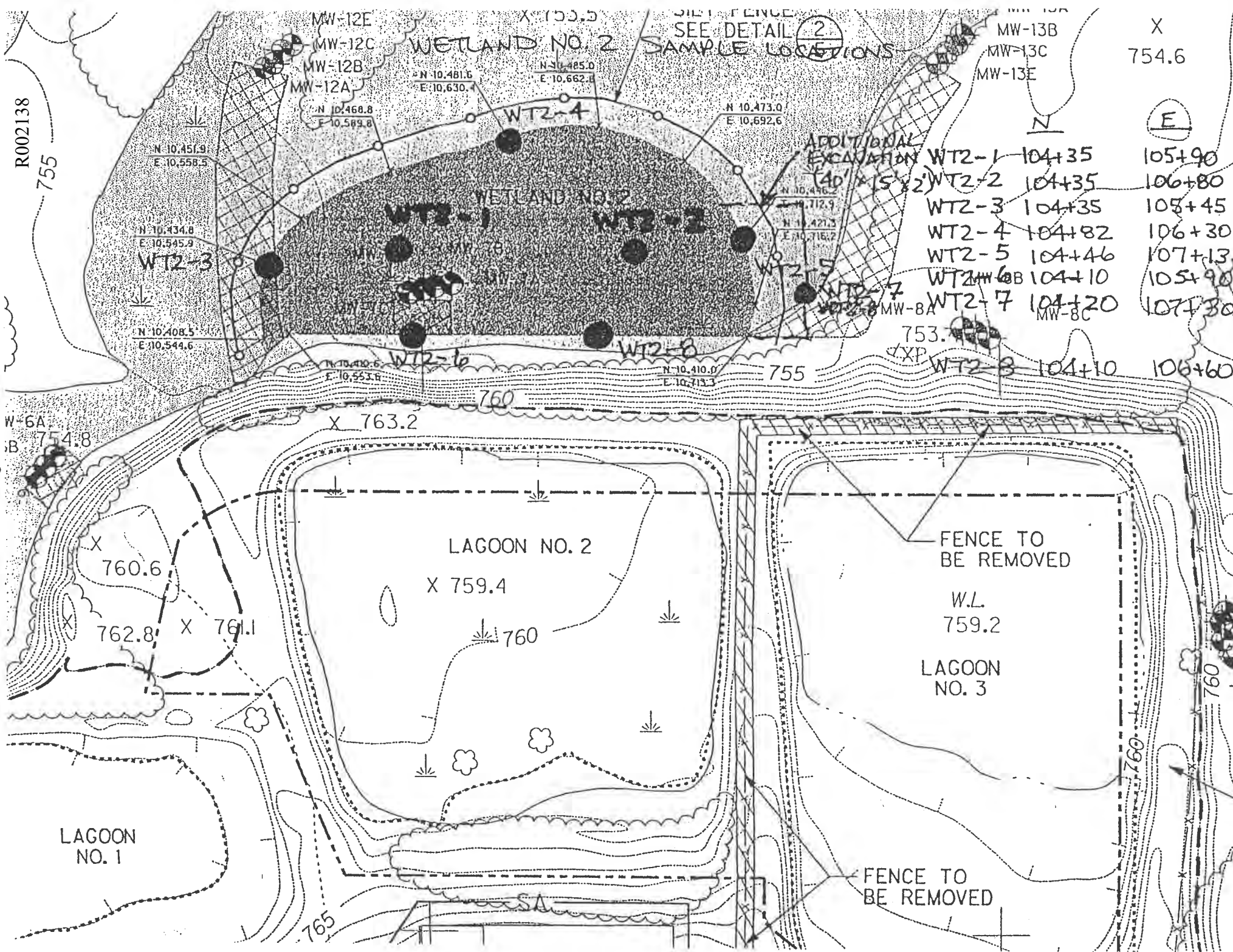

SILEY FENCE
 SEE DETAIL (2)
 SAMPLE LOCATIONS

ADDITIONAL EXCAVATION (40' x 15' x 2')

WT2-1	104+35	105+90
WT2-2	104+35	106+80
WT2-3	104+35	105+45
WT2-4	104+82	106+30
WT2-5	104+46	107+13
WT2-6	104+10	105+90
WT2-7	104+20	107+30
WT2-8	104+10	106+60

R002138
755

X
754.6

(E)

LAGOON NO. 2

FENCE TO BE REMOVED

W.L.
759.2

LAGOON NO. 3

FENCE TO BE REMOVED

LAGOON NO. 1

760
75

WT3-1 ~~107~~¹⁰⁸+25 108+20
 WT3-2 107+00 108+20
 WT3-3 106+82 107+77
 WT3-4 106+50 108+25
 WT3-5 106+67 108+68

WT3-6 106+10 108+20
 WT3-7 106+10 107+75
 WT3-8 106+15 108+75

WETLAND NO. 3 SAMPLE LOCATIONS

11,000 E

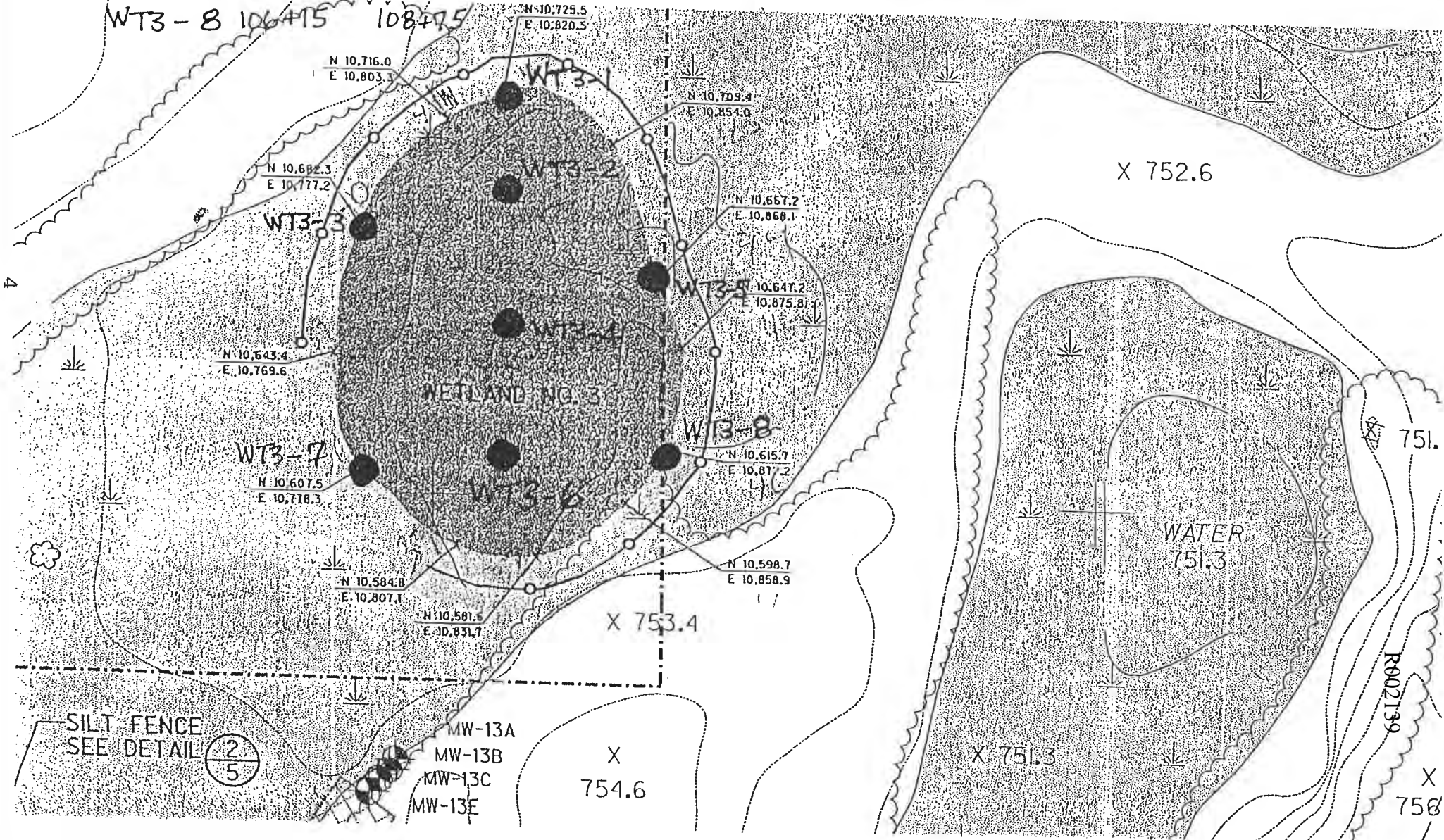

71

7/18/00

97M015

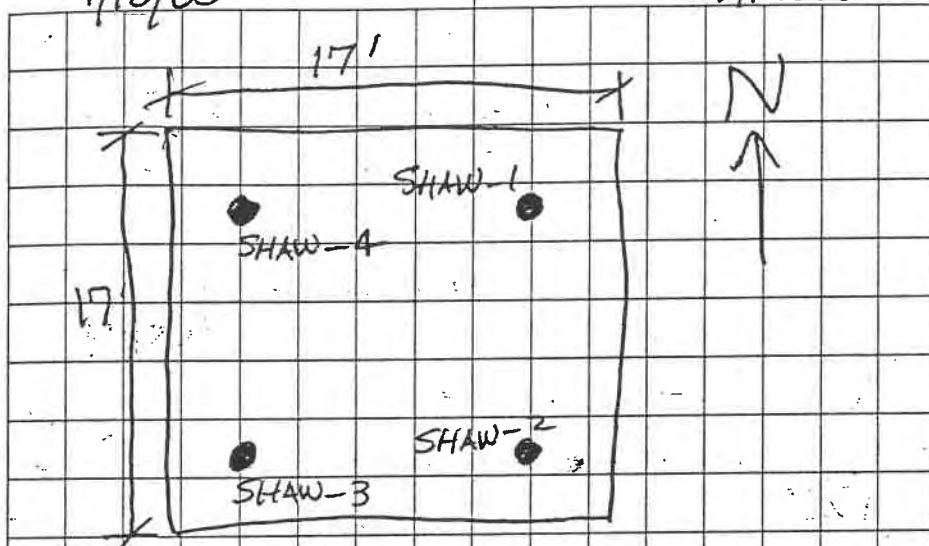

SHAWNEE BLDG. EXCAVATION

12 - 17 5 0

TestAmerica

INCORPORATED

Mr. Ron Meister
FOTH & VAN DYKE
2737 S. Ridge Road
P.O. Box 19012
Green Bay, WI 54307

07/24/2000
Job Number: 00.07681
IEPA Cert. No.: 100221
WDNR Cert. No.: 999447130

Enclosed is the Analytical and Quality Control reports for the following samples submitted to Bartlett Division of TestAmerica for analysis.

Project Description: Modern Plating Corp./97M015

Sample Number	Sample Description	Date Taken	Date Received
589293	SHAW-1	07/18/2000	07/19/2000
589294	SHAW-2	07/18/2000	07/19/2000
589295	SHAW-3	07/18/2000	07/19/2000
589296	SHAW-4	07/18/2000	07/19/2000

Sample analysis in support of the project referenced above has been completed and results are presented on the following pages. These results apply only to the samples analyzed. Reproduction of this report only in whole is permitted. Please refer to the enclosed "Key to Abbreviations" for definition of terms. Procedures used follow TestAmerica Standard Operating Procedures which reference the methods listed on your report. Should you have questions regarding procedures or results, please do not hesitate to call. TestAmerica has been pleased to provide these analytical services for you.

This Quality Control report is generated on a batch basis. All information contained in this report is for the analytical batch(es) in which your sample(s) were analyzed.

Approved by:

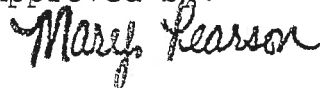

Mary Pearson
Project Manager



ANALYTICAL REPORT

Mr. Ron Meister
 FOTH & VAN DYKE
 2737 S. Ridge Road
 P.O. Box 19012
 Green Bay, WI 54307

07/24/2000

Sample No. : 589293

Job No.: 000.07681

Sample Description: SHAW-1
 Modern Plating Corp./97M015

Date Taken: 07/18/2000
 Time Taken: 16:35

Date Received: 07/19/2000
 Time Received: 13:40

Parameter	Result	Flag	Units	Reporting Limit	Date Analyzed	Analyst Initials	Analytical Method
Solids, Total	79.3		%	0.1	07/21/2000	kmt	SM 2540
Cadmium, ICP	<0.63		mg/kg dw	0.63	07/24/2000	kdw	SW 6010B



ANALYTICAL REPORT

Mr. Ron Meister
 FOTH & VAN DYKE
 2737 S. Ridge Road
 P.O. Box 19012
 Green Bay, WI 54307

07/24/2000

Sample No. : 589294

Job No.: 00.07681

Sample Description: SHAW-2
 Modern Plating Corp./97M015

Date Taken: 07/18/2000
 Time Taken: 16:40

Date Received: 07/19/2000
 Time Received: 13:40

Parameter	Result	Flag	Units	Reporting Limit	Date Analyzed	Analyst Initials	Analytical Method
Solids, Total	79.0		%	0.1	07/21/2000	kmt	SM 2540
Cadmium, ICP	<0.63		mg/kg dw	0.63	07/24/2000	kdw	SW 6010B



ANALYTICAL REPORT

Mr. Ron Meister
 FOTH & VAN DYKE
 2737 S. Ridge Road
 P.O. Box 19012
 Green Bay, WI-54307

07/24/2000

Sample No. : 589295

Job No. : 00.07681

Sample Description: SHAW-3
 Modern Plating Corp./97M015

Date Taken: 07/18/2000
 Time Taken: 16:45

Date Received: 07/19/2000
 Time Received: 13:40

Parameter	Result	Flag	Units	Reporting Limit	Date Analyzed	Analyst Initials	Analytical Method
Solids, Total	78.6		%	0.1	07/21/2000	kmt	SM 2540
Cadmium, ICP	<0.64		mg/kg dw	0.64	07/24/2000	kdw	SW 60109



ANALYTICAL REPORT

Mr. Ron Meister
 FOTH & VAN DYKE
 2737 S. Ridge Road
 P.O. Box 19012
 Green Bay, WI 54307

07/24/2000

Sample No. : 589296

Job No.: 00.07681

Sample Description: SHAW-4
 Modern Plating Corp./97M015

Date Taken: 07/18/2000
 Time Taken: 16:50

Date Received: 07/19/2000
 Time Received: 13:40

Parameter	Result	Flag	Units	Reporting Limit	Date Analyzed	Analyst Initials	Analytical Method
Solids, Total	78.7		%	0.1	07/21/2000	kmc	SM 2540
Cadmium, ICP	0.64		mg/kg dw	0.64	07/24/2000	kdw	SW 6010B

TestAmerica, Bartlett Division
TestAmerica
 KEY TO ABBREVIATIONS: TESTING METHODS REFERENCES
 INCORPORATED

- < : Less than; When appearing in the results column indicates the analyte was not detected at or above the reported value.
- mg/L : Concentration in units of milligrams of analyte per liter of sample. Measurement used for aqueous samples. Can also be expressed as parts per million (ppm).
- ug/g : Concentration in units of micrograms of analyte per gram of sample. Measurement used for non-aqueous samples. Can also be expressed as parts per million (ppm) or mg/Kg.
- ug/L : Concentration in units of micrograms of analyte per liter of sample. Measurement used for aqueous samples. Can also be expressed as parts per billion (ppb).
- ug/Kg : Concentration in units of micrograms of analyte per kilogram of sample. Measurement used for non-aqueous samples. Can also be expressed as parts per billion (ppb).
- TCLP : These initials appearing in front of an analyte name indicate that the Toxicity Characteristic Leaching Procedure (TCLP) was performed for this test.
- Surr: : These initials are the abbreviation for surrogate. Surrogates are compounds that are chemically similar to the compounds of interest. They are part of the method quality control requirements.
- % : Percent; To convert ppm to %, divide the result by 10,000.
 To convert % to ppm, multiply the result by 10,000.
- ICP : Indicates analysis was performed using Inductively Coupled Plasma Spectroscopy.
- AA : Indicates analysis was performed using Atomic Absorption Spectroscopy.
- GFAA : Indicates analysis was performed using Graphite Furnace Atomic Absorption Spectroscopy.
- PQL : Practical Quantitation Limit; the lowest level that can be reliably achieved within specified limits of precision and accuracy during routine laboratory operating conditions.

Method References

- (1) Methods 1000 through 9999: see "Test Methods for Evaluating Solid Waste", USEPA SW-846, 3rd Edition, 1986.
- (2) ASTM "American Society for Testing Materials"
- (3) Methods 100 through 499: see "Methods for Chemical Analysis of Water and Wastes", USEPA, 600/4-79-020, Rev. 1983.
- (4) See "Standard Methods for the Examination of Water and Wastewater", 17th Ed, APHA, 1989.
- (5) Methods 600 through 625: see "Guidelines Establishing Test Procedures for the Analysis of Pollutants", USEPA Federal Register Vol. 49 No. 209, October 1984.
- (6) Methods 500 through 599: see "Methods for the Determination of Organic Compounds in Drinking Water," USEPA 600/4-88/039, Rev. 1988.
- (7) See "Methods for the Determination of Metals in Environmental Samples", Supplement I EPA-600/R-94/111, May 1994.
- (8) See "Standard Methods for the Examination of Water and Wastewater", 18th Ed., APHA, 1992.
- (9) Methods 1000 through 9999: see "Test Methods for Evaluating Solid Waste", USEPA SW-846, 3rd Edition, 1986, Including Updates I and II.
- (10) This method is from the 2nd Edition of "Test Methods for Evaluating Solid Waste", USEPA SW-846. It has been dropped from the 3rd Edition, 1986.

Regional Office & Laboratory
5 Science Drive
Madison, WI 53711
608-232-3300 • Fax: 608-233-0502
1-888-5-ENCHEM



Corporate Office & Laboratory
1795 Industrial Drive
Green Bay, WI 54302
920-469-2436 • Fax: 920-469-8827
1-800-7-ENCHEM

- Analytical Report -

Project Name : MODERN PLATING

Client : FOTH & VAN DYKE

Project Number : 97M015

Report Date : 2/25/00

WI DNR LAB ID : 113172950

Lab Sample No.	Field ID	Collection Date	Lab Sample No.	Field ID	Collection Date
900618-001	MP-I-6-2.5	2/23/00			
900618-002	MP-I-10-2.5	2/23/00			
900618-003	MP-I-13-2.5	2/23/00			

I certify that the data contained in this Final Report has been generated and reviewed in accordance with approved methods and Laboratory Standard Operating Procedure. Exceptions, if any, are discussed in the accompanying sample narrative. Release of this final report is authorized by Laboratory management, as is verified by the following signature.

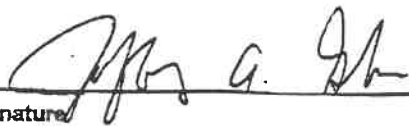
Approval Signature

2.25.00
Date

25-2000 09-18
ision Office & Laboratory
5 Science Drive
Madison, WI 53711
608-232-3300 • Fax: 608-233-0502
1-888-5-ENCHEM



P. 03/05
Corporate Office & Laboratory
1799 Industrial Drive
Green Bay, WI 54302
920-469-2436 • Fax: 920-469-8827
1-800-7-ENCHEM

- Analytical Report -

Project Name : MODERN PLATING
Project Number : 97M015
Field ID : MP-I-6-2.5
Lab Sample Number : 900618-001
Lab Project Number : 900618

Submitter : FOTH & VAN DYKE
Report Date : 2/25/00
Collection Date : 2/23/00
Matrix Type : SOIL
WI DNR LAB ID : 113172950

Inorganic Results

Test	Result	EQL	Units	Code	Analysis Date	Prep Method	Analysis Method
Cadmium	0.73	0.13	mg/kg		2/24/00	SW846 3051	SW846 6010B
Solids, percent	75.0		%		2/25/00	SM 2540G M	SM 2540G M

All soil results are reported on a dry weight basis unless otherwise noted.

Madison Office & Laboratory
25 Science Drive
Madison, WI 53711
608-232-3300 • Fax: 608-233-0502
1-888-5-ENCHEM



Corporate Office & Laboratory
1700 Industrial Drive
Green Bay, WI 54302
920-469-2436 • Fax: 920-469-8827
1-800-7-ENCHEM

- Analytical Report -

Project Name : MODERN PLATING

Submitter : FOTH & VAN DYKE

Project Number : 97M015

Report Date : 2/25/00

Field ID : MP-I-10-2.5

Collection Date : 2/23/00

Lab Sample Number : 900618-002

Matrix Type : SOIL

Lab Project Number : 900618

WI DNR LAB ID : 113172950

Inorganic Results

Test	Result	EQL	Units	Code	Analysis Date	Prep Method	Analysis Method
Cadmium	2.7	0.14	mg/kg		2/24/00	SW846 3051	SW846 6010B
Solids, percent	72.4		%		2/25/00	SM 2540G M	SM 2540G M

All soil results are reported on a dry weight basis unless otherwise noted.



- Analytical Report -

Project Name : MODERN PLATING
Project Number : 97M015
Field ID : MP-I-13-2.5
Lab Sample Number : 900618-003
Lab Project Number : 900618

Submitter : FOTH & VAN DYKE
Report Date : 2/25/00
Collection Date : 2/23/00
Matrix Type : SOIL
WI DNR LAB ID : 113172950

Inorganic Results

Test	Result	EQL	Units	Code	Analysis Date	Prep Method	Analysis Method
Cadmium	56	0.16	mg/kg		2/24/00	SW846 3051	SW846 6010B
Solids, percent	61.9		%		2/25/00	SM 2540G M	SM 2540G M

All soil results are reported on a dry weight basis unless otherwise noted.

(Please Print Legibly)

Company Name: **FOTH & VAN DYKE**
 Branch or Location: **GREEN BAY, WI**
 Project Contact: **RON MEISTER**
 Telephone: **920-497-2500**
 Project Number: **97M015**
 Project Name: **MODERN PLATING**
 Project State: **ILLINOIS**
 Sampled By (Print): **REP**



1241 Bellevue St., Suite 9
 Green Bay, WI 54302
 920-469-2436 • 1-800-736-2436
 FAX 920-469-8827

525 Science Drive
 Madison, WI 53711
 608-232-3300 • 1-888-536-2436
 FAX: 608-233-0502

1423 N. 8th Street, Suite 122
 Superior, WI 54880
 715-392-5844 • 1-800-837-8238
 FAX 715-392-5843

CHAIN OF CUSTODY

56236

*Preservation Codes
 A=None B=HCL C=H2SO4 D=HN03 E=EnCore F=Methanol G=NaOH

FILTERED? (YES/NO)
 PRESERVATION (CODE)*

ANALYSES REQUESTED
Cadmium

Data Package Options (please circle if requested)
 QC Summary Surcharge Site-Specific QC Required?
 EnChem Level II Std. Delivery Yes No
 EnChem Level III 10% (min. \$50) (If yes, indicate QC sample and submit triplicate volume.)
 EnChem Level IV 25% (min. \$100)

Page _____ of _____
 P.O. # _____ Quote # _____
 Mail Report To: _____
 Company: _____
 Address: _____
 Invoice To: _____
 Company: _____
 Address: _____
 Mail Invoice To: _____

LABORATORY ID (Lab Use Only)	FIELD ID	COLLECTION		DATE	TIME	MATRIX	COMMENTS	TOTAL BOTTLES (Lab Use Only)
		DATE	TIME					
MP-I-6-2.5		2/23/00	945	X		S	24 Hr Turn	
MP-I-10-2.5		↓	1100	X				
MP-I-13-2.5		↓	1140	X				
COPY								

Turnaround Time Requested (TAT)
 (circle): Std (10 Bus. Days) Rush
 (Rush TAT subject to approval/surcharge)
 Quick Turn Number: _____
 Date Needed: _____
 Transmit Rush Results by (circle):
 Phone Fax
 Phone #: _____
 Fax #: _____
 Samples on HOLD are subject to special pricing and release of liability

Std. TAT Surcharge
 1 day 3.0x
 2 day 2.0x
 3 day 1.5x
 4 day 1.4x
 5 day 1.3x

Matrix Codes:
 W=Water
 S=Soil
 A=Air
 C=Charcoal
 B=Biota
 Sl=Sludge

Relinquished By: **Ron Pappie** Date/Time: **2/24/00 - 1205**
 Relinquished By: _____ Date/Time: _____
 Relinquished By: _____ Date/Time: _____
 Relinquished By: _____ Date/Time: _____
 Relinquished By: _____ Date/Time: _____

Received By: **Jim M** Date/Time: **2-24-00 12:05**
 Received By: _____ Date/Time: _____
 Received By: _____ Date/Time: _____
 Received By: _____ Date/Time: _____
 Received By: _____ Date/Time: _____

En Chem Project No. _____
 Sample Receipt Temp _____
 Sample Receipt (Wet/Media) _____
 Custody Seal _____